

OPERATING MANUAL

VISATRON® Oil Mist Detector

VN2020/VN2020 EX



Version date: 05/06/2026
Version: Version 3.1
Document No.: Part number 183001

The original operating manual is written in German.
Any translations are based on the original operating manual.

LEGAL NOTICE

The operating manual applies to the following products:

- VISATRON[®] VN2020
- VISATRON[®] VN2020 EX

Firmware version at time of publication:
V2.03 dated 12/04/2024

Copyright

This manual is protected by copyright. All rights are reserved.

We reserve the right to make technical changes to the hardware and software of our VISATRON[®] products without prior notice. We do not assume any liability for a currently delivered device having all the features described in this operating manual.

The reproduction, translation, microfilming and the storage and processing of this manual, including in part, is only allowed with the consent of Schaller Automation Industrielle Automationstechnik GmbH & Co. KG.

Any infringement shall attract damages and may have consequences under criminal law. Specifications of nominal conditions, technical changes, improvements and errors are excepted.

This operating manual may only be passed on to third parties in conjunction with the transfer of the relevant VISATRON[®] device.

Copyright © 2026

Schaller Automation Industrielle Automationstechnik GmbH & Co. KG
Industriering 14
66440 Blieskastel Saarland
Germany

Phone: +49 6842- 508- 0
Fax: +49 6842- 508- 260

Email: info@schaller.de
Website: www.schaller-automation.com

VERSION HISTORY AND CHANGE NOTES

Version	Change	Date	Author
1.0	<ul style="list-style-type: none"> • Release (first version) 	19/12/2019	P. Adams / S. Höh
1.1	<ul style="list-style-type: none"> • Safety instructions, terminology and positions of parts added • Definition of maintenance records; revision of graphics and text 	13/03/2020	P. Adams / S. Höh
1.2	<ul style="list-style-type: none"> • Photos and positions of parts added or replaced • Error code corrected • Revision of text in some sections 	13/03/2020	J. Hönninger
2.0	<ul style="list-style-type: none"> • Layout changed for the entire operating manual • Photos and positions of parts added or replaced • Added new maintenance kits and spare parts tables 	01/12/2021	G. Kornatz
2.1	<ul style="list-style-type: none"> • Revised/added to Section 8.2 	27/06/2022	J. Hönninger
3.0	<ul style="list-style-type: none"> • Revised all content against the standard, based on version 2.1. <ul style="list-style-type: none"> ➔ The technical functionality and properties of the device remain unaffected by the changes! • Reorganised and adapted content of all sections • Added further sections • New layout with revised formatting 	24/01/2024	J. Wahl
3.1	<ul style="list-style-type: none"> • Updated release version (legal notice) • Section 1.7: Supplement: Additional Obligations of the Operator • Section 3.1: Cleaned up text • Sections 6.3.2 / 6.3.3: Alignment criteria and photo documentation added • Sections 6.3.4-6.3.6: Tightening torques corrected / added • New Section 6.3.8 (Installing the recirculation line) added • Added product photos in Section 6.4.3 • Section 9.3.6 step 8: Added threadlocker • Sections 6.4.2 / 9.3.6: Tightening torques corrected / added • Section 9.1.5: Tightening torques corrected / added • Sections 10.2.1 / 10.2.2: Error code 35 added; table optimised • Section 10.2.2: Error code "12" corrected; table optimised • Section 13: Added to / reorganised and restructured the section • Added product photo in Section 13.1.2 • Section 17: Declarations of conformity (non-EX / EX) adapted to new legal regulations • Last page: Added QR code • Cleaned up text and photos / corrected errors in all sections 	05/06/2026	J. Wahl

Table 1 : Version history and change notes

Table of contents

1	Information about the operating manual	9
1.1	Symbols in this operating manual	9
1.2	Validity of the operating manual	9
1.3	Use and purpose of the operating manual	9
1.4	Document storage	10
1.5	Applicable documents and regulations	10
1.6	Qualifications of personnel	10
1.7	Operator's obligations	11
1.8	Conformity	11
1.9	Liability for defects	12
1.10	Terms of warranty	12
1.11	Version of the operating manual	13
1.12	Digital operating manual (online operating manual)	13
1.13	Variables and units of measurement that are used	13
1.14	Legal information about the product	14
2	Safety instructions	15
2.1	Safety devices and guards	15
2.2	Warnings	15
2.2.1	Structure of warnings	15
2.2.2	Hazard levels in warnings	15
2.3	Information, warning and mandatory signs that are used	17
2.4	Basic safety instructions	18
2.4.1	Safety instructions for potentially explosive atmospheres	21
3	Identification	22
3.1	Marking and type description	22
3.2	Manufacturer's details	22
3.3	Name plate	23
3.3.1	Name plate for the VISATRON® VN2020/VN2020 EX measuring head	23
3.3.2	Name plate for the complete VISATRON® VN2020/VN2020 EX device	25
3.4	Technical data	28
3.4.1	Mechanical interfaces (M)	29
3.4.2	Electrical interfaces (E)	29
3.4.3	Pneumatic interfaces (P)	30
3.4.4	Environmental conditions	30
3.4.5	Type approval	31

4	Product overview	32
4.1	Component overview for the VISATRON® VN2020 oil mist detection system	32
4.1.1	Component overview with standard drainage concept	32
4.1.2	Component overview with siphon block concept (alternative)	33
4.2	Component overview for the VISATRON® VN2020/VN2020 EX oil mist detector	34
4.3	Technical description and technical data	36
4.3.1	Function of the VISATRON® VN2020/VN2020 EX oil mist detector	36
4.3.2	Device variants	37
4.3.3	Bracket	37
4.3.4	Header pipe	38
4.3.5	Engine wall connection (EWC) and sampling funnel	38
4.3.6	Siphon block	39
4.3.7	Hose lines	39
4.3.8	Pipe siphon	40
4.3.9	Remote Indicator II for VISATRON® VN2020/VN2020 EX (optional)	41
4.3.10	Setting the device sensitivity	41
4.4	Intended use	42
4.5	Foreseeable misuse	42
4.6	Descriptions of the controls and indicators	43
4.6.1	Controls and indicators, VISATRON® VN2020/ VN2020 EX	43
5	Transport and storage	44
5.1	Unpacking and items included in delivery	44
5.2	Transport	44
5.3	Storage conditions before starting up	44
6	Assembly and installation	46
6.1	Preparatory steps by the customer	46
6.1.1	Establishing the compressed air supply	46
6.1.2	Establishing the electrical power supply	46
6.1.3	Preparation for signal transfer from the alarm contacts	47
6.1.4	Preparation for CANopen communication (optional)	47
6.1.5	Preparation for RS485 and Modbus communication (optional, e.g. for Remote Indicator II) ...	47
6.2	Setting up	47
6.3	Assembling the system components	48
6.3.1	Class-compliant assembly and installation according to IACS Unified Requirement UR M10.	49
6.3.2	Installing the oil mist detector with pre-assembled bracket	49
6.3.3	Installing the oil mist detector without bracket	51
6.3.4	Installing the engine wall connection and sampling funnel	53
6.3.5	Installing the siphon block assembly	59

6.3.6	Installing the pipe siphon assembly.....	66
6.3.7	Installing the pipes.....	71
6.3.8	Installing the recirculation line	72
6.3.9	Installation of the hose lines	75
6.3.10	Installing Remote Indicator II for remote monitoring (optional)	76
6.4	Electrical installation	79
6.4.1	Connection options for the oil mist detector (overview)	80
6.4.2	Electrical installation of the terminal box for the VN2020 series	81
6.4.3	Electrical connection of the Remote Indicator II (optional).....	89
6.4.4	Closing the terminal box after completing the electrical installation.....	91
6.4.5	Connecting housing earth to the protective cover of the VN2020.....	91
6.5	Starting up for the first time	93
6.5.1	Checklist for starting up for the first time	94
6.5.2	Connecting the power supply	95
6.5.3	Setting the negative pressure at the measuring head of the VN2020/VN2020 EX	96
6.5.4	Setting the sensitivity on the VN2020/VN2020 EX oil mist detector	100
6.5.5	Function test when starting up for the first time	102
6.5.6	Factory test by the engine builder with smoke generator on starting up.....	104
7	Manufacturer settings	109
7.1	Parameter settings, VISATRON® VN2020/VN2020 EX	109
8	Operation and use	114
8.1	Check every time before operation	114
8.2	Operation under correct conditions	115
8.3	Switching the device on and off.....	115
8.4	Normal operation	115
8.5	LED check	116
8.6	Checking the supply pressure, sensor OMC and sensitivity	117
8.7	“Oil mist pre-alarm” status indicator	117
8.8	“Oil mist alarm” status indicator	117
8.9	Confirming an oil mist alarm	119
9	Maintenance and repair	120
9.1	Maintenance by the operator.....	120
9.1.1	Maintenance cycles for reliable operation	122
9.1.2	Cleaning the light path on the measuring head (4,000 hours)	124
9.1.3	Replacing the air filter element on the pressure reducer unit (4,000 hours)	129
9.1.4	Function test of the oil mist detector using smoke tube (4,000 hours).....	134
9.1.5	Replacing the seal on the connecting box (8,000 hours).....	137
9.2	Inspection of the oil mist detector (16,000 hours or after 24 months)	143

9.3	Repair by the operator	143
9.3.1	Replacing the VN2020/VN2020 EX measuring head	144
9.3.2	Replacing the fuse on the VN2020/VN2020 EX measuring head	150
9.3.3	Replacing the seal on the inspection cover	152
9.3.4	Replacing the seal on the mounting plate.....	152
9.3.5	Replacing the inspection cover screw plug.....	153
9.3.6	Replacing the terminal box on the VN2020/VN2020 EX	155
9.3.7	Replacing the filter control valve on the VN2020/VN2020 EX	162
9.3.8	Replacing the connecting hose on the VN2020/VN2020 EX.....	167
9.4	Repair by Schaller Automation	170
9.5	Taking out of service and disassembly.....	170
9.6	Starting up again	170
10	Error diagnosis and troubleshooting.....	171
10.1	Behaviour of the oil mist detector in the event of a fault	171
10.1.1	Defect in the measuring head	172
10.2	Error diagnosis and troubleshooting	173
10.2.1	Error diagnosis	173
10.2.2	Troubleshooting	174
11	Final shutdown and disposal.....	176
11.1	Disposal	176
11.2	Final shutdown	176
12	Contact	177
13	Spare parts and accessories, VN2020/VN2020 EX	178
13.1	Emergency Spare parts (kept in stock), VN2020.....	178
13.1.1	Cleaning kit for VN2020/VN2020 EX	180
13.1.2	Service box for VN2020/VN2020 EX	181
13.2	Emergency Spare parts (kept in stock), VN2020 EX.....	182
13.2.1	Cleaning kit for VN2020 EX	183
13.2.2	Service box for VN2020/VN2020 EX	183
13.3	Maintenance Spare parts	184
13.3.1	Maintenance kit (4,000/8,000/12,000 hours)	184
13.3.2	Service kit for VN2020 (16,000 hours/24 months)	185
13.4	Upgrade Spare parts.....	187
13.5	Accessories	188
14	List of figures	190
15	List of tables	192
16	Glossary	193
17	EC Declaration of Conformity	194

18	Attachments	196
18.1	Description of error on the VN2020/VN2020 EX oil mist detector	196
19	Notes	199
20	Index	200
21	Customer information	201

1 Information about the operating manual

1.1 Symbols in this operating manual

Various types of notation and symbols are used in the text of this manual. They are used as follows:

Numbered steps:

- ▶ Required action
- Result of the sequence of actions
- Symbol for a list

1. Points of the list

⇒ *Reference to a section or figure*

Display text

 Additional information and instructions

 Environmental and energy-saving tips

 Different warning symbols are used for warnings. Please see the descriptions and instructions in Section. ⇒ *Section 2 Safety instructions*

1.2 Validity of the operating manual

This operating manual applies to the following products:

- VISATRON[®] VN2020
- VISATRON[®] VN2020 EX,

hereafter referred to as the “device”.

1.3 Use and purpose of the operating manual

The operating manual is intended for:

- the operator of the device; and
- the qualified personnel responsible for installing, starting up, operating and servicing the device.

This operating manual will support you to:

- carry out initial assembly and installation as intended;
- operate the device safely and in accordance with its intended use;
- avoid hazards;
- carry out maintenance and repair work as intended and thereby reduce repair costs and long downtimes;
- guarantee or increase the reliability and service life of the device;

- select and order spare parts and accessories; and
- find authorised service partners local to you

- ▶ Hazard warnings, safety regulations and the information in this operating manual must be observed without exception.
- ▶ You must read, understand and apply the operating manual in order to operate and work on the device properly and safely.
- ▶ This operating manual must be read and applied by the fitter and the responsible specialist personnel/operator **before** transport, installation/removal, starting up, operation and maintenance.

1.4 Document storage

- ▶ This manual, as well as all other applicable documents, must be kept in a central place so that they are always available to the qualified personnel at the place of use.
- ▶ The documents must be handed over in full to subsequent owners.

1.5 Applicable documents and regulations

Further documents apply and must be observed in conjunction with this operating manual:

- ▶ Operating manual for VISATRON[®] VN2020 **end user software**, currently valid version (Document No.: Part Number 180115, available on the supplied DVD)
- ▶ For additional components, the manuals supplied with them must be observed.
- ▶ When using the device and for all service work, also follow:
 - the recognised technical rules for working safely and correctly;
 - the statutory accident prevention regulations;
 - the statutory environmental protection regulations;
 - the provisions of the employers' liability insurance association;
 - the regulations applicable in other countries and the requirements for the state of the art; and
 - the rules and instructions of the operator.

1.6 Qualifications of personnel

Installation, starting up, operation and maintenance of the device may only be carried out by appropriately qualified personnel.

The operator must therefore ensure that the personnel for the work/activities defined in this operating manual have the appropriate qualifications and/or are trained and fully understand the contents of this operating manual.

The following operator qualifications are required for this device:

- completed vocational training as an electrician (electronics technician) or mechatronics technician, industrial mechanic **or** equivalent technical training; and
- instruction by the operator on the instructions for the entire installation on site.

Certain maintenance work may only be carried out by authorised specialist personnel. The operator must define and provide rules for the area of responsibility, the authority and the supervision of personnel for such work in advance.

1.7 Operator's obligations

- ▶ Only employed qualified and instructed maintenance and installation personnel.
- ▶ Define rules for the authority and supervision of personnel.
- ▶ Check all safety devices regularly to ensure they are functioning and complete.
- ▶ Ensure that scheduled maintenance is carried out as planned.
- ▶ Inform the manufacturer of any damage that is identified (caused by delivery or incorrect use).
- ▶ Provide personnel with the necessary protective equipment.
- ▶ Replace damaged parts.
- ▶ Keep the work areas and escape routes clear and in good condition.
- ▶ Inform yourself of the health and safety regulations applicable at the place of use.
- ▶ In a risk assessment, also identify hazards that arise from the specific working conditions at the place of use.
- ▶ Implement the knowledge gained from the risk assessment in the form of instructions.
- ▶ Modifications to the engine and its associated systems, carried out by the operator particularly those that may affect operational safety, compliance with statutory regulations, or the classification of the vessel, must be reported to the competent classification society prior to the commencement of the work. This applies in particular to:
 - New installations,
 - Retrofit measures, or
 - Upgrades.

1.8 Conformity

The device is safely designed and built according to the applicable technical rules. The device complies with the safety requirements of the following directives:

- Machinery Regulation (EU) 2023/1230
- EMC Directive 2014/30/EU
- ATEX Directive 2014/34/EU

Applied harmonised standards:

- EN ISO 12100:2010-11
- EN ISO 4414:2010-11
- EN 60529:2014-09
- EN 61000-6-1:2019-11
- EN 61000-6-2: 2019-11
- EN 61000-6-3: 2011-09
- EN 61000-6-4: 2011-09
- EN IEC 60079-0:2019-09, EN 60079-28:2016-04

Applied national standards and technical specifications:

- IACS UR M10: Rev.4 2013
- IACS UR M67: Rev.2 2015
- IEC 60079-0 (2019) and IEC 60079-28 (2016-04)

1.9 Liability for defects

The terms in the order confirmation from Schaller Automation Industrielle Automationstechnik GmbH & Co. KG or the terms agreed in the contract apply.

Claims for personal injury and damage are excluded if they are due to one or more of the following causes:

- use not as intended ⇒ *Section 4.5 Foreseeable misuse*
- foreseeable misuse ⇒ *Section 4.5 Foreseeable misuse*
- technical data ⇒ *Section 3.4 Technical data*
- technical description ⇒ *Section 4.3 Technical description and technical data*

1.10 Terms of warranty

The terms of warranty are part of the “General Terms and Conditions” or the purchase contract.

The warranty provided by Schaller Automation Industrielle Automationstechnik GmbH & Co. KG does not apply in the following cases:

- Incorrect installation, maintenance and servicing of the device, by insufficiently qualified personnel.
- Operating the device with safety devices that are not properly attached or are not functioning.
- Failure to observe the instructions, commands and prohibitions in the operating manual.
- Unauthorised structural changes to the device.
- Inadequate monitoring of wear parts.
- Maintenance work not carried out correctly **or** not carried out on time.
- Unauthorised modifications to the device may invalidate the warranty.
- Retrofitting and modifications to the device or installation kit are only allowed after consulting Schaller Automation Industrielle Automationstechnik GmbH & Co. KG;
- Transport damage as a result of incorrect handling.

The following also applies in addition:

- ▶ Statutory regulations must be observed.
- ▶ Do not make any unauthorised changes or manipulate the device.
- ▶ Only use correct and approved materials.
- ▶ Only use approved and suitable spare parts. ⇒ *Section 13 Spare parts and accessories, VN2020/VN2020 EX*
- ▶ Normal wear and tear is not a “malfunction” for the purposes of the terms of warranty.

1.11 Version of the operating manual

This document has been prepared to the best of our knowledge and belief. It matches the technical version of the device as delivered.

Schaller Automation Industrielle Automationstechnik GmbH & Co. KG reserves the right to amend and revise this document, if necessary. The products supplied by Schaller Automation are production devices with long service life, developed and produced according to the current state of the art. There is therefore a range of factors that may require revision of this document, such as:

- Knowledge gained during starting up.
- Knowledge gained during maintenance and repairs.
- Additional requirements from customers and authorities.
- Changes to standards and regulations.
- Modernisation and overhaul of plant.
- Extensions to the scope of the order by the client.
- Knowledge gained by the operator regarding plant safety and plant operation.

The version of the document is indicated by the version date and the version number on the title page. The version number can also be found in the footer on every page of this document. The operator must check that the document is up-to-date.

1.12 Digital operating manual (online operating manual)

The current version of this operating manual is also available online and can be accessed at any time. You can find the manual under:

[Operating manual | Schaller Automation \(schaller-automation.com\)](https://www.schaller-automation.com)

To access the manual, select the manual for your product on our online portal and then start downloading by clicking the  icon. The document then opens automatically in your browser.

1.13 Variables and units of measurement that are used

The following table lists the variables and units of measurement that are currently used in the operating manual. We reserve the right to add to or change the table, as necessary.

Variable	Unit
Lengths	mm, m
Volume	m ³ , l
Standard volume flow, according to DIN 1343 [at 1013 mbar and 273.15 K (0 °C)]	Nm ³ /h, Nm ³ /min, Nm ³ /s
Volume flow	l/min, m ³ /min, l/h, m ³ /h
Mass	g, kg
Temperature	°C, K
Density	kg/m ³
Frequency	Hz
Pressure	mbar, bar, mmWC

Relative humidity (RH)	%
Oil mist concentration	mg/l
Opacity	%
Acceleration (vibration)	g, m/s ²
Voltage	V (volt)
Current	A (amps)
AC voltage	AC
DC voltage	DC
Torque (M)	Nm

Table 2 : Variables and units of measurement that are used

1.14 Legal information about the product

For all legal questions and activities arising in connection with the above product, please contact SCHALLER Automation in advance:

SCHALLER Automation (Headquarters)
Industrielle Automationstechnik GmbH & Co. KG

Industriering 14
66440 Blieskastel/Saarland
Germany

Phone: +49 6842 508-0
Fax: +49 6842 508-260

Email: info@schaller.de
Website: www.schaller-automation.com

2 Safety instructions

This operating manual contains safety instructions.

2.1 Safety devices and guards

This manual contains instructions for your safety. The following basic safety instructions are instructions that always apply in order to operate the machine safely and keep the machine in a safe condition.

The warnings that relate to specific actions warn you about residual hazards and are provided before any hazardous step.

- ▶ All instructions must be followed to prevent personal injury, environmental damage or property damage.

2.2 Warnings

Warnings indicate potential residual hazards before an action.

2.2.1 Structure of warnings

Warnings are provided before hazardous steps. Warnings have the following structure:



SIGNAL WORD

Nature and source of the hazard!

Description of the nature and source of the hazard.

- ▶ Measures to prevent the hazard.

2.2.2 Hazard levels in warnings

The warnings have different levels according to the severity of the hazard. The hazard levels with the corresponding signal words and warning symbols are described below.



DANGER

Immediate risk of death or serious injury.

- ▶ Indicates a high-risk hazard which, if not avoided, will result in death or serious injury.



WARNING

Potential risk of death or serious injury.

- ▶ Indicates a medium-risk hazard which, if not avoided, could result in death or serious injury.

**CAUTION**

Potential risk of minor injury.

- ▶ Indicates a low-risk hazard that, if not avoided, may result in minor or moderate injury.













NOTE

Potential damage to the device or the surroundings.

- ▶ Indicates a potential hazard, with the aim of preventing damage.

2.3 Information, warning and mandatory signs that are used

The following symbols and signs according to DIN EN ISO 7010 and DIN 4844-2 are used in this operating manual:

Symbol	Explanation
	General warning sign
	Warning; electricity
	Warning; explosive atmosphere (Atex)
	Warning; explosive atmosphere (Atex; IECEx)
	Warning; hot surface
	Warning; overhead load
	Disconnect before carrying out maintenance or repair
	Connect an earth terminal to the ground
	Wear protective gloves
	Wear ear protection
	Wear eye protection
	Wear head protection





Symbol	Explanation
	Refer to operating manual/instructions
	Note: Important information!
	Note: A qualified electrician is required for installation!
	Note: Action required!

Table 3 : Information, warning and mandatory signs

2.4 Basic safety instructions

The basic safety instructions are instructions that always apply in order to operate the machine safely and keep the device in a safe condition.

If the following safety instructions are not observed, the following may occur:

- there may be personal injury, environmental damage or damage to property;
- important functions of the device may fail;
- specified methods of maintenance and servicing may fail;
- any claims may fail.
- ▶ Observe the following instructions for your own protection and for the protection of your surroundings.
- ▶ If necessary, draw people's attention to the safety instructions and warnings.



CAUTION

Safe and proper use of the device

- ▶ Read the operating manual and other documents that accompany the product carefully and keep them in a suitable place for future reference.
- ▶ For repair and service work, you must follow the instructions in the operating manual.



NOTE

Personal protective equipment

Operating the device or working on the device without protective equipment may result in serious injury. For the workplace PPE, the following protective equipment must be used:

- ▶ DIN EN 388:2016 Protective gloves against mechanical risks, 2341X, and DIN EN 407:2020-06, Protective gloves against thermal risks, X1XXXX
- ▶ Safety glasses in accordance with DIN EN 166 or DIN EN 170
- ▶ Safety helmet in accordance with DIN EN 397 and DIN EN 50365
- ▶ ESD safety shoes according to ESD standard DIN EN 61340-5-1



DANGER
Malfunction

Operating the device with a malfunction creates a risk of death and may cause environmental damage and/or damage to the device.

- ▶ The device must be taken out of operation immediately in the event of a malfunction.



DANGER
Mechanical hazards

There is a risk of serious injury, including death, from explosion in the crankcase as a result of incorrect assembly or installation.

- ▶ You may only install and remove the oil mist detector when the engine is switched off.
- ▶ The oil mist detector must be levelled horizontally and vertically during installation.
- ▶ The oil mist detector must not be painted, varnished or otherwise altered.
- ▶ To carry out a trial mist test of the oil mist detector while the engine is running, the mist inlet screw must be opened. Open it as briefly as possible, as an explosive atmosphere can escape and cause a risk of explosion.
- ▶ Only trained specialist personnel are allowed to carry out assembly, installation and starting up of the oil mist detector. The qualified personnel must have knowledge of the type of protection, instructions and regulations for the equipment in potentially explosive atmospheres. Check whether the classification (see name plate) is applicable for this application.
- ▶ The device must be installed in accordance with IACS Unified Requirement UR M10.



DANGER
Pneumatic hazards

Assembly, installation and disassembly of the device must only be carried out when the device is not under pressure.

- ▶ Before starting work, deactivate the compressed air supply to the VISATRON[®] VN2020/VN2020 EX.





Risk of asphyxiation or explosion of the crankcase atmosphere in the engine room.

- ▶ The exhaust air from the intake system (venturi injector) must be returned to the crankcase and must not get into the engine room. The following therefore applies:
- ▶ The exhaust air line of the oil mist detector must always be connected to the crankcase (closed circuit). The correct negative pressure in the measuring head should be 60 mmWC.

Return of the exhaust air into the crankcase

- ▶ The oil mist detector with return of the crankcase atmosphere into the crankcase is suitable for a crankcase pressure in the range of ± 500 mmWC under normal operating conditions.

⚠ DANGER

Electrical hazards

Electrical damage to the device from welding work on the engine as a result of overvoltage.

- ▶ Before starting work, disconnect the VISATRON® VN2020/VN2020 EX from the power supply.





Electrical damage to the device on when installing and removing the engine.

- ▶ Before starting work, disconnect the VISATRON® VN2020/VN2020 EX from the power supply.

Electrical damage during repair work on the device

- ▶ Before starting work, disconnect the VISATRON® VN2020/VN2020 EX from the power supply or make sure that the housing is safely earthed.

⚠ DANGER









Risk of burns

Depending on the media that are used, the installation location and the operating mode, the surfaces of the device and the connected parts of the system may become hot. The heat can cause serious injury.

- ▶ Insulate the device against heat radiation on installation, depending on the wall temperature.
- ▶ Make sure that the surfaces have cooled down sufficiently.
- ▶ Install guards that prevent contact with the device.
- ▶ Observe the allowed ambient temperature T_a (during intended use): $+5\text{ °C} \leq T_a \leq +70\text{ °C}$.
- ▶ Typical gases of ignition protection category T4: T4 maximum surface temperature must be $\leq 135\text{ °C}$.
- ▶ Wear suitable protective gloves.

⚠ DANGER

Noise pollution

At the mounting position of the device, there are high noise emissions from running of the engine, which can damage hearing and cause environmental noise pollution.

- ▶ Take measures to protect against noise when installing the device.
- ▶ Wear suitable ear protection during operation.
- ▶ Observe the statutory regulations for protection against noise.

**NOTE****Maintenance and repair work**

It is only safe to operate the device when it is in perfect working condition. The operator is responsible for proper and safe condition of the device, which means:

- ▶ Have the specified inspections and maintenance work carried out regularly.
- ▶ Carry out the specified checks before operation.

2.4.1 Safety instructions for potentially explosive atmospheres**⚠ DANGER****Explosion of the crankcase, for dual-fuel or gas engines**

There is a risk of serious injury, including death, from explosion in the crankcase as a result of incorrect assembly or installation.

- ▶ The oil mist detector is designed to draw in gases from a potentially explosive atmosphere (for example, the crankcase of a gas engine). The device **without** ATEX approval must therefore never be used in potentially explosive atmospheres.

**⚠ DANGER****Hazards in potentially explosive atmospheres**

The following basic safety instructions apply to SCHALLER products intended for use in potentially explosive atmospheres:

- ▶ Only personnel trained for potentially explosive atmospheres may handle and install the product.
- ▶ Make that the product is approved for the application ⇒ *Section 3.1 Marking and type description*
- ▶ Always comply with the zoning to install the product in the correct location. (Avoid zone carryover) ⇒ *Section 3.1 Marking and type description*
- ▶ Only use tools suitable for potentially explosive atmospheres.
- ▶ Note that modifications are not allowed without prior approval from SCHALLER AUTOMATION.
- ▶ Make sure that damaged products are not installed or operated in the potentially explosive atmosphere.
- ▶ Modifications to the device or the electrical connections mean that it is no longer safe to operate and there is no longer protection against explosion.
- ▶ Observe the characteristics and rated operating conditions on the type and data plates.
- ▶ Observe the national and local safety regulations, accident prevention regulations and assembly and installation regulations.
- ▶ Observe the general safety instructions.
- ▶ Observe the generally recognised rules of technology.
- ▶ Observe any additional information signs on the device.

3 Identification

3.1 Marking and type description

This operating manual is for the VISATRON[®]-branded, series VN2020 oil mist detector.

The oil mist detector is available in two device variants:

- VISATRON[®] VN2020, for use in environments that are **not** potentially explosive according to ATEX and IECEx
- VISATRON[®] VN2020 EX, for use in environments that **are** potentially explosive with gas engine operation according to ATEX and IECEx:

ATEX: II (2G) [Ex op is IIB T4 Gb]

IECEx: [Ex op is IIB T4 Gb]

Gaseous fuels, such as biogas, natural gas, landfill gas, mine gas or wood gas as engine fuel, consist of up to 90% methane gas.

The VISATRON[®] VN2020 EX is designed to draw in gases from a potentially explosive atmosphere, for example, from the crankcase of a gas engine. However, the oil mist detector itself must not be installed in a potentially explosive environment, although an EX zone may develop in the measuring head of the device.

The differences between the VISATRON[®] VN2020 EX and the VN2020 are primarily indicated by the following external features:

- Inspection cover: Painted in “blue” colour
- Measuring head name plate: EX symbol and EX marking instead of the Schaller logo
- Name plate of the complete device: Additional EX symbol after the type designation

3.2 Manufacturer's details

Schaller Automation

Industrielle Automationstechnik GmbH & Co. KG

Industriering 14

66440 Blieskastel/Saarland

Germany

Phone: +49 6842 508-0

Fax: +49 6842 508-260

Email: info@schaller.de

Website: www.schaller-automation.com

3.3 Name plate

The product is identified by a name plate

- for the measuring head (separately on the measuring head of the VISATRON[®] VN2020/VN2020 EX)
- and
- for the complete device (on the connecting box of the VISATRON[®] VN2020/VN2020 EX)

i The serial number on the name plate contains information about the product and is important for replacement orders and overhauls. The serial number is assigned once for each product. The manufacturer can use this number to identify all the product data.

3.3.1 Name plate for the VISATRON[®] VN2020/VN2020 EX measuring head

The name plate is attached to the outside of the measuring head as shown in the figure below.

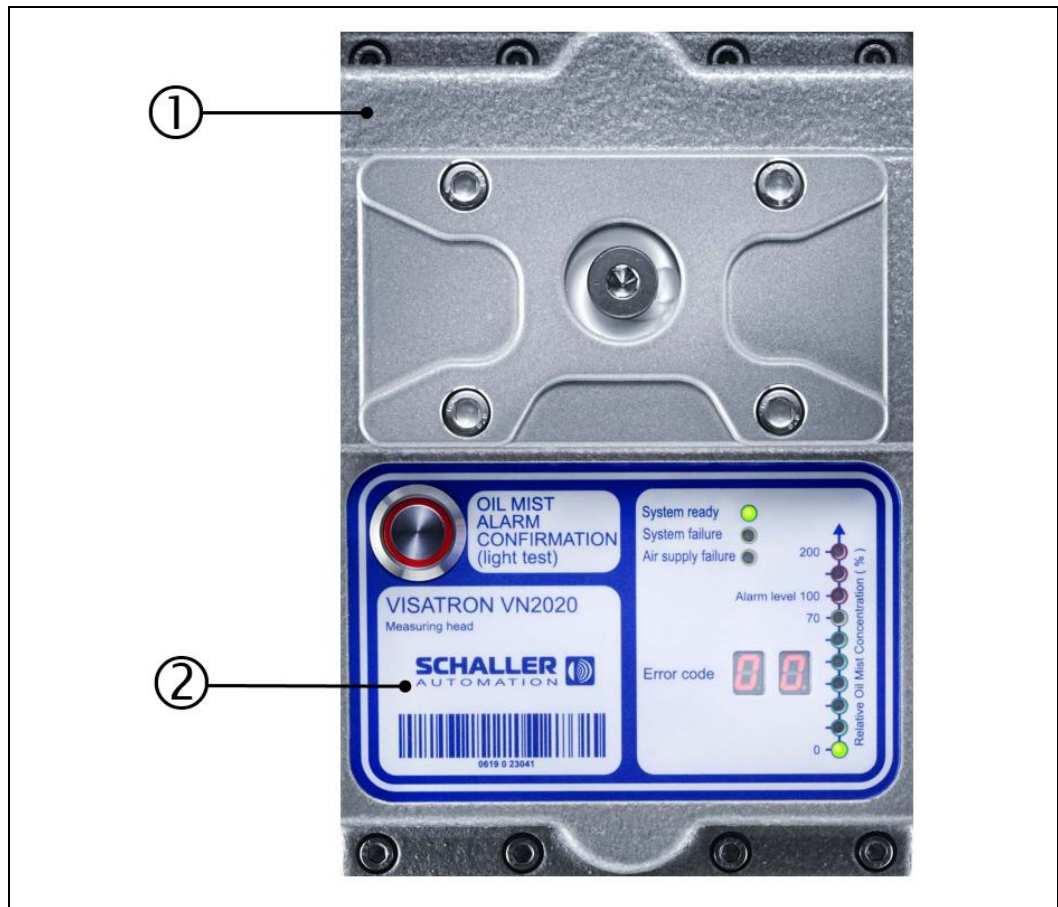

Fig.: 1 : Name plate, VISATRON[®] VN2020 measuring head

1: VISATRON[®] VN2020 measuring head

2: VISATRON[®] VN2020 name plate

The following information is provided on the name plate (②):



Fig.: 2 : Name plate, VISATRON® VN2020 measuring head

- 1: Device type and designation
- 2: Manufacturer/company logo
- 3: Barcode with serial number (example)

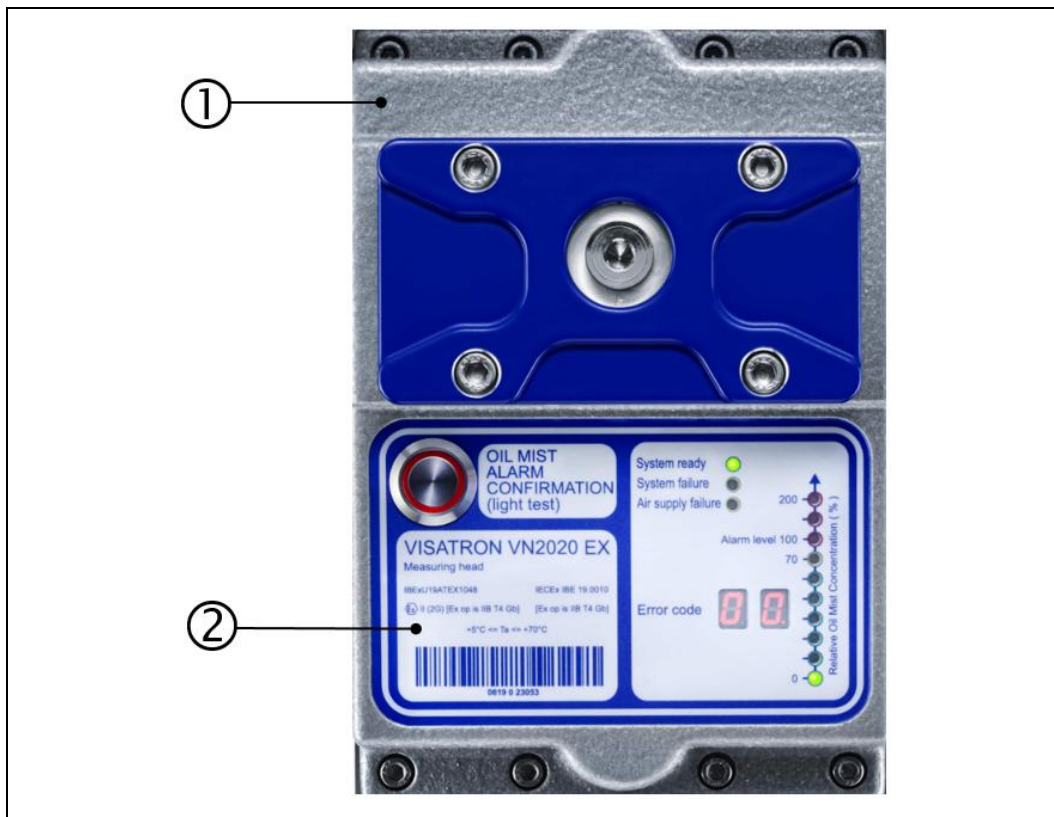

Fig.: 3 : Name plate, VISATRON® VN2020 EX measuring head

- 1: VISATRON® VN2020 EX measuring head
- 2: VISATRON® VN2020 EX name plate

The following information is provided on each name plate (②):



Fig.: 6 : Name plate, VISATRON® VN200 connecting box

- 1: Manufacturer's details/company logo
- 2: Device type and designation
- 3: Barcode with serial number (example)
- 4: CE marking
- Manufacturer's production period (example)
- Manufacturer's part number (example)

 The number under the barcode is identical to the serial number.



Fig.: 7 : Name plate, VISATRON® VN200 EX connecting box

- 1: Connecting box
- 2: Name plate

The following information is provided on each name plate (②):



Fig.: 8 : Name plate, VISATRON® VN2020 EX connecting box

- | | |
|---|--------------------------------|
| 1: Manufacturer's details/company logo | 2: Device type and designation |
| 3: Barcode with serial number (example)
Manufacturer's production period (example)
Manufacturer's part number (example) | 4: CE marking |

 The number under the barcode is identical to the serial number.

3.4 Technical data

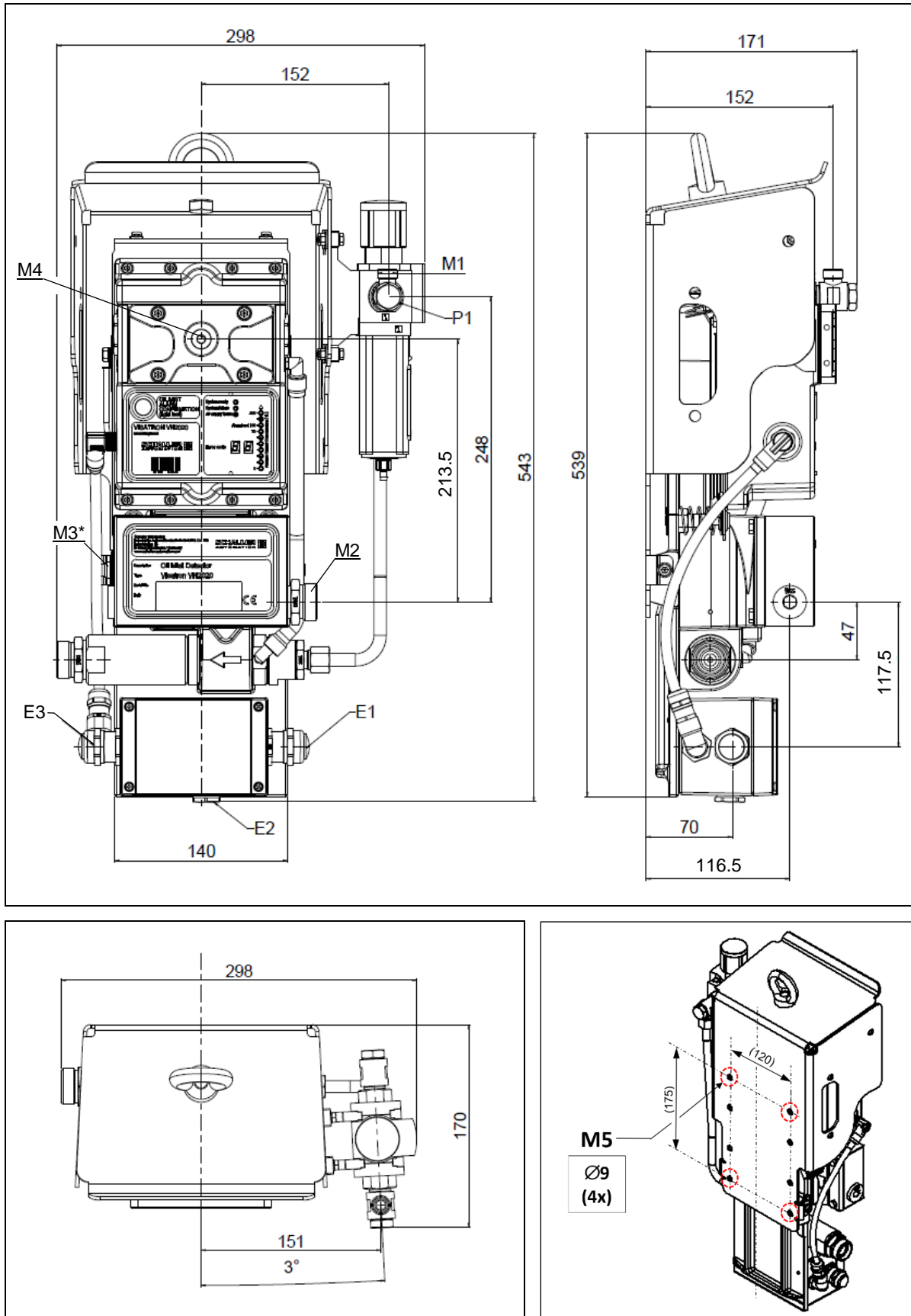

Fig.: 9: Mechanical dimensions, VISATRON® VN2020/VN2020 EX

3.4.1 Mechanical interfaces (M)

⇒ Section 6.3.2 Installing the oil mist detector with pre-assembled bracket

VN2020/VN2020 EX oil mist detector	
Max. dimensions (L x W x H)	approx. 539 x 298 x 171 mm
Weight	12.4 kg
M1	External thread M16x1.5 Pipe connection, diameter size 10
M2	External thread M30x2 Pipe connection, diameter size 22
M3* *) Connection on standard device is using a screw plug	Female thread G1/2 on the connecting box
M4	Internal thread G1/4
M5	4 x through-holes (Ø9) on the protective cover, for M8 fixing screws

Table 4 : Mechanical interfaces

3.4.2 Electrical interfaces (E)

⇒ Section 6.4.2 Electrical installation

VN2020/VN2020 EX oil mist detector	
Power supply	18 - 31.2 V DC
Nominal voltage	24 V DC
Current consumption	Maximum 2 A
Supply E1/E3	24 V DC M20 (E1)/M25 (E3): Cable diameter 8-16 mm; earthing via holes in base plate during installation <u>Possible wire cross-sections:</u> $0.08 \leq \varnothing \leq 2.5 \text{ (mm}^2\text{)}$
Supply E2	M20: Cable diameter 5-13 mm <u>Possible wire cross-sections:</u> $0.08 \leq \varnothing \leq 2.5 \text{ (mm}^2\text{)}$
Relay outputs	2 x "High Oil Mist Alarm" 1 x "Ready" (ready for operation) 1 x "Oil Mist Pre-Alarm" (max. 60 Volt AC/DC, 1A)
Communication interface with monitoring device	3-wire RS485, electrically isolated/CANopen, electrically isolated <u>Possible wire cross-sections:</u> $0.08 \leq \varnothing \leq 2.5 \text{ (mm}^2\text{)}$

Recommended communication cable	<p>LAPP bus cable UNITRONIC® BUS 2 x 2 x 0.22 mm² Colour: Purple, max. 400 m length</p> <p>The bus cable can be purchased from:</p> <ul style="list-style-type: none"> • LAPP: Part No.: 2170204, or • Schaller Automation: Part No.: 230140
---------------------------------	---

Table 5 : Electrical interfaces

3.4.3 Pneumatic interfaces (P)

⇒ Section 6.5.3 Setting the negative pressure at the measuring head of the VN2020/VN2020 EX

VN2020/VN2020 EX oil mist detector	
Compressed air supply to P1	Min. 2 bar Max. 14 bar
Compressed air consumption	1.2 Nm ³ /h ± 10% (according to DIN 1343) Value may vary depending on customer solution
Negative pressure	Position M4 Measure and adjust negative pressure Min. -55 mmWC (-5.5 mbar) Nom. -60 mmWC (-6 mbar) Max. -65 mmWC (-6.5 mbar)
Compressed air quality	ISO 8573-1:2010 - 6-4-4

Table 6 : Pneumatic interfaces

3.4.4 Environmental conditions

Environmental conditions	
Operating temperature	+5 °C to +70 °C
Storage temperature	-25 °C to +50 °C
Max. approval-compliant vibrations for the device	5 Hz to 25 Hz: 1.6 mm (max. displacement) 25 Hz to 100 Hz: 4g (40 m/s ²) (max. acceleration)
Relative humidity	up to 95%
IP protection rating	IP 54

Table 7 : Ambient conditions and physical characteristics

3.4.5 Type approval

Type approval for closed areas	
	Type approval for closed areas, designed for installation on combustion engines, environmental category D (DNV-GL), compliant with IACS UR M67; list of type approvals at www.schaller-automation.com

Table 8 : Type approval for closed areas

4 Product overview

4.1 Component overview for the VISATRON[®] VN2020 oil mist detection system

4.1.1 Component overview with standard drainage concept

An oil mist detection system, referred to as an installation kit, usually consists of the following for delivery.

The oil mist detection system is usually configured specifically for the engine.

The figure below shows a typical installation of a VISATRON[®] VN2020 oil mist detection system for a six-cylinder engine, which consists of the following components:

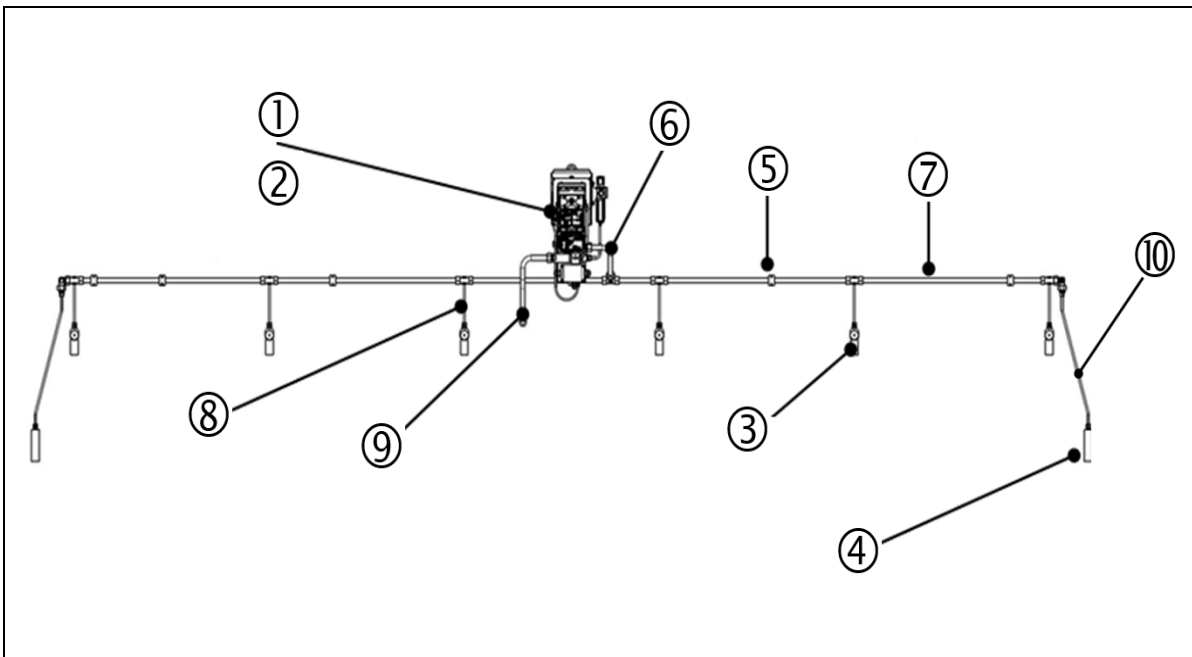



Fig.: 10 : Component overview, standard drainage, VISATRON[®] VN2020

- | | |
|--|---|
| 1: VN2020 (Non Ex/Ex) oil mist detector | 2: Bracket (customer-specific) |
| 3: Engine wall connection | 4: Pipe siphon |
| 5: Pipe bracket (header pipe) | 6: Intake pipe for connecting box |
| 7: Header pipe | 8: Intake pipe for engine wall connection |
| 9: Exhaust air pipe (recirculation line) | 10: Intake pipe for pipe siphon |

 Depending on customer requirements, items ⑥, ⑧, ⑨ and ⑩ can be supplied as a rigid version (pipe) or as a flexible line.

4.1.2 Component overview with siphon block concept (alternative)

The drainage concept with siphon block is the alternative to the standard drainage concept and is always used when the standard drainage concept with the pipe siphon (Fig. 10, 4) cannot be used for reasons associated with the application.

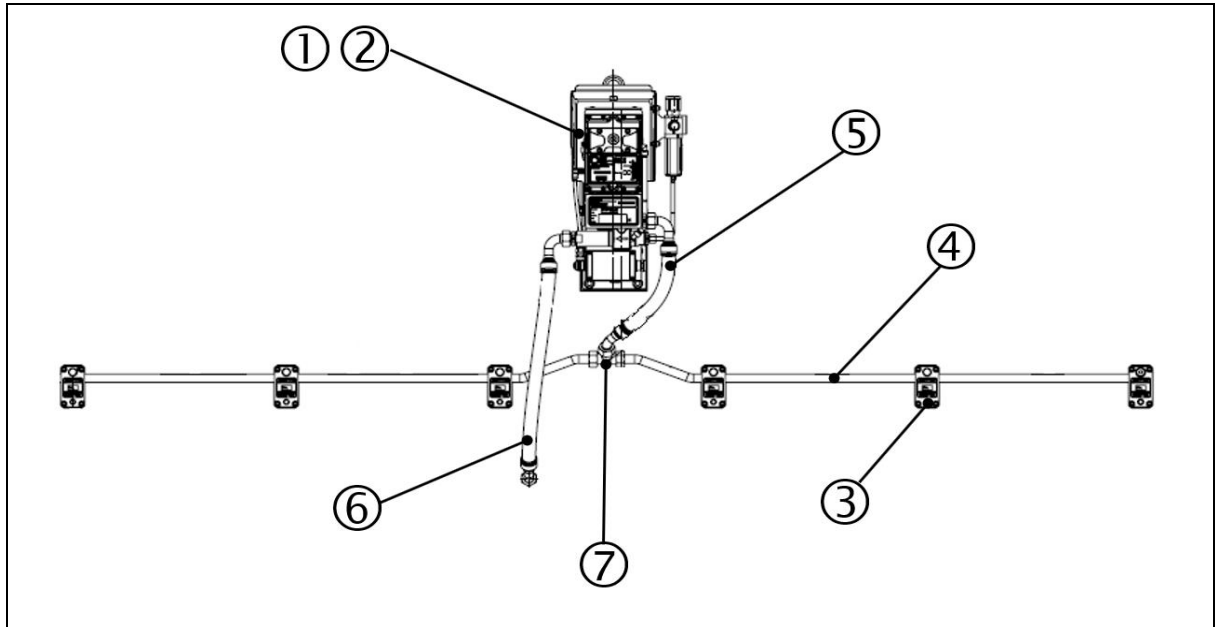



Fig.: 11 : Component overview, drainage concept with siphon block, VISATRON® VN2020

- | | |
|---|--|
| 1: VN2020 (Non Ex/Ex) oil mist detector | 2: Bracket (customer-specific) |
| 3: Siphon block | 4: Header pipe |
| 5: Intake pipe for connecting box | 6: Exhaust air pipe (recirculation line) |
| 7: Pipe connector | |

 Depending on customer requirements, items ⑤ and ⑥ can be supplied as a rigid version (pipe) or as a flexible line.

4.2 Component overview for the VISATRON[®] VN2020/VN2020 EX oil mist detector

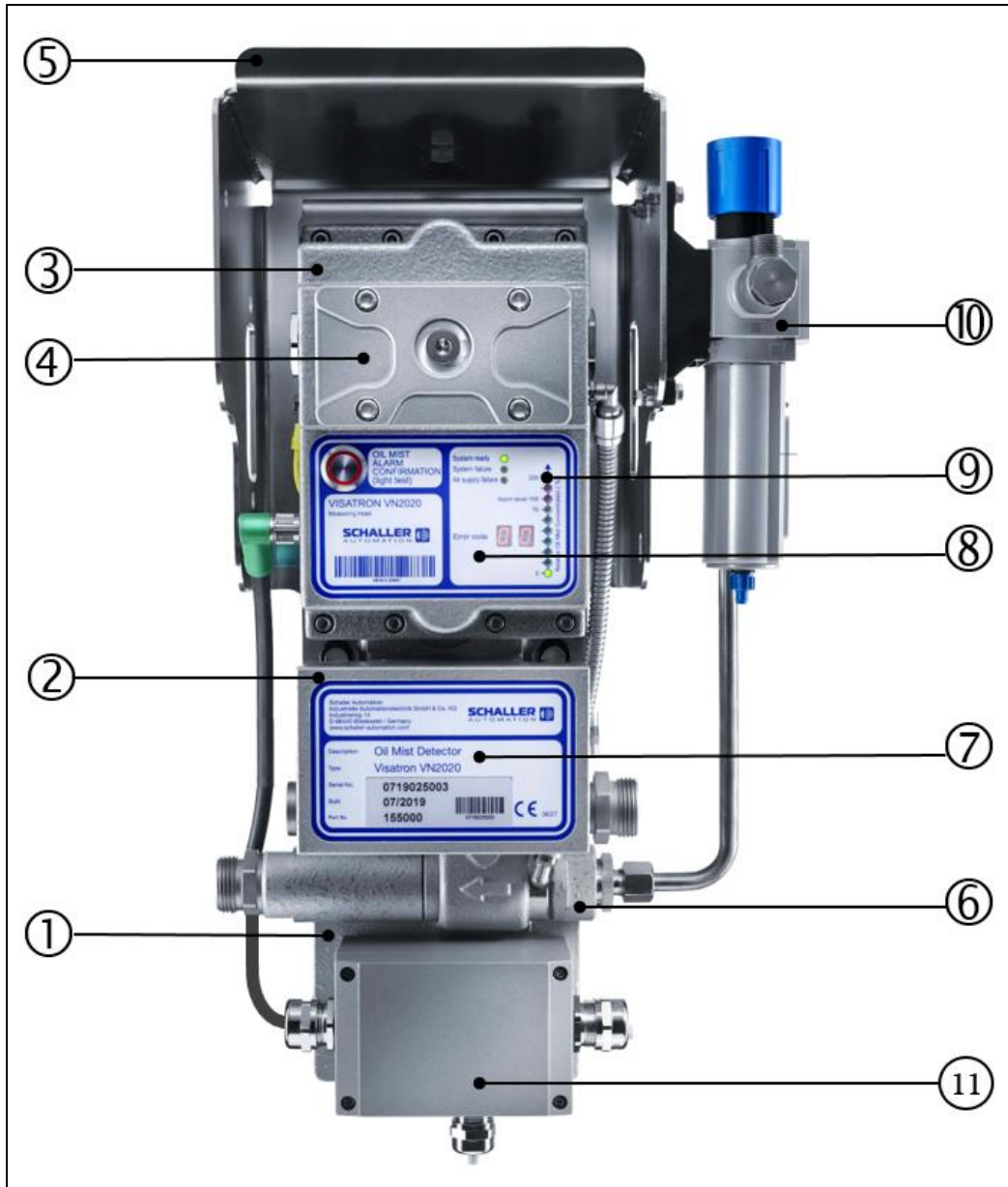

Fig.: 12 : Component overview for the VISATRON[®] VN2020 oil mist detector

- | | |
|--|------------------------------|
| 1: Base plate | 2: Connecting box |
| 3: Measuring head | 4: Inspection cover |
| 5: Protective cover | 6: Venturi air jet pump |
| 7: Name plate of the oil mist detector | 8: Measuring head name plate |
| 9: Display with error code | 10: Filter control valve |
| 11: Terminal box | |

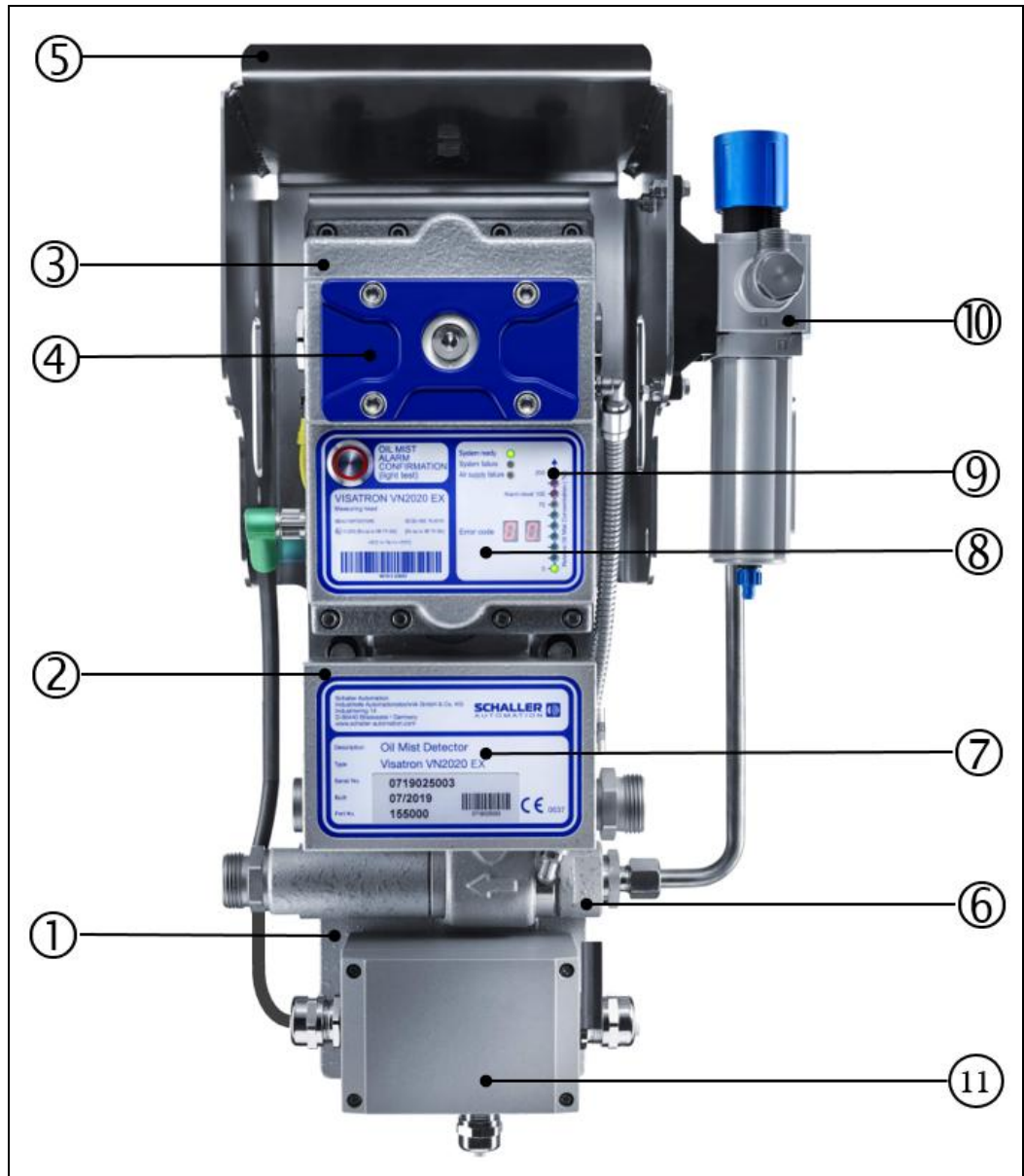

Fig.: 13 : Component overview for the VISATRON[®] VN2020 EX oil mist detector

- | | |
|--|-----------------------------------|
| 1: Base plate | 2: Connecting box |
| 3: Measuring head (EX) | 4: Inspection cover (EX) |
| 5: Protective cover | 6: Venturi air jet pump |
| 7: Name plate of the oil mist detector | 8: Measuring head name plate (EX) |
| 9: Display with error code | 10: Filter control valve |
| 11: Terminal box | |

4.3 Technical description and technical data



NOTE

The figures below are for descriptive purposes only.
We reserve the right to vary the size and design of the device and accessories at any time.

4.3.1 Function of the VISATRON[®] VN2020/VN2020 EX oil mist detector

The VISATRON[®] VN2020/VN2020 EX oil mist detector from Schaller Automation is designed to protect large engines (gas, diesel and dual fuel) from oil mist explosions caused by the spontaneous development of oil mist in the crankcase. It is part of a safety system to protect the life and health of operating personnel and it permanently prevents serious consequential damage.

The central part of the oil mist detector, as shown in [Fig. 12](#) and [Fig. 13](#), is the measuring head (Pos.3), which includes an optical measuring track under the inspection cover (Pos.4) and an LED display (Pos.9) to display all important information for the user under normal operating conditions. The measuring head is attached to the base plate (Pos.1) via a vibration-protected mounting plate.

The oil mist detector uses the *Venturi principle* to draw the oil mist atmosphere out of the crankcase. The negative pressure generated by the Venturi air jet pump (Pos.6) at the device is used to draw in the oil mist-containing crankcase atmosphere from the crankcase via the engine wall connections ([Fig. 10](#), Pos.3). It then passes through the header pipes ([Fig. 10](#), Pos.7) and the intake line ([Fig. 10](#), Pos.6) into the connecting box and from there into the optical measuring track in the measuring head, where the oil mist concentration is continuously measured and analysed. From there, the crankcase atmosphere returns to the crankcase via the recirculation line ([Fig. 10](#), Pos.9).

The active and continuous sampling of the crankcase atmosphere ensures that there are short response times between the formation of oil mist and the oil mist alarm to be generated.

To avoid false alarms in the crankcase, such as from spray oil, the intake system uses sampling funnels specially developed by Schaller Automation that can always be used, regardless of the direction of rotation of the engine. However, Schaller Automation recommends installing in accordance with [Fig. 28](#) of this manual. One sampling funnel is always required per sampling point, which is directly connected to the engine wall connection.

To avoid residues of oil (condensed crankcase atmosphere) in the intake lines, Schaller Automation uses its own tried-and-tested drainage concept to return the excess oil to the engine crankcase.

Additional draining components ensure that the system operates correctly under all operating conditions.

The measures described for the device to function correctly mean that the VISATRON[®] VN2020/VN2020 EX oil mist detector can be used primarily in maritime applications, i.e. on ships with their static angle of inclination (heel) or dynamic roll angle (roll), as well as in stationary applications such as power stations.

The oil mist detector was developed and approved by SCHALLER AUTOMATION in compliance with the mandatory IACS UR M10 requirements.

4.3.2 Device variants

When used on large engines that have mandatory explosion protection classification, an oil mist detector with corresponding ATEX or IECEx approval must be used in potentially explosive atmospheres.

The VISATRON® VN2020/VN2020 EX oil mist detector from Schaller Automation can be used as follows:

- Non-Ex version of the device; only approved for operation **outside** of potentially explosive atmospheres
- EX version of the device; approved for operating **inside** potentially explosive atmospheres



DANGER

Explosion of the crankcase, for dual-fuel or gas engines

There is a risk of serious injury, including death, from explosion in the crankcase as a result of incorrect assembly or installation.

- ▶ The oil mist detector is designed to draw in gases from a potentially explosive atmosphere (for example, the crankcase of a gas engine). The device **without** ATEX or IECEx approval must therefore never be used in potentially explosive atmospheres.

4.3.3 Bracket

The bracket is used to hold the oil mist detector and to connect the oil mist detector to the engine housing.

When designing the installation kits, this bracket is adapted to the engine geometry or designed for the applicable application, for each customer.

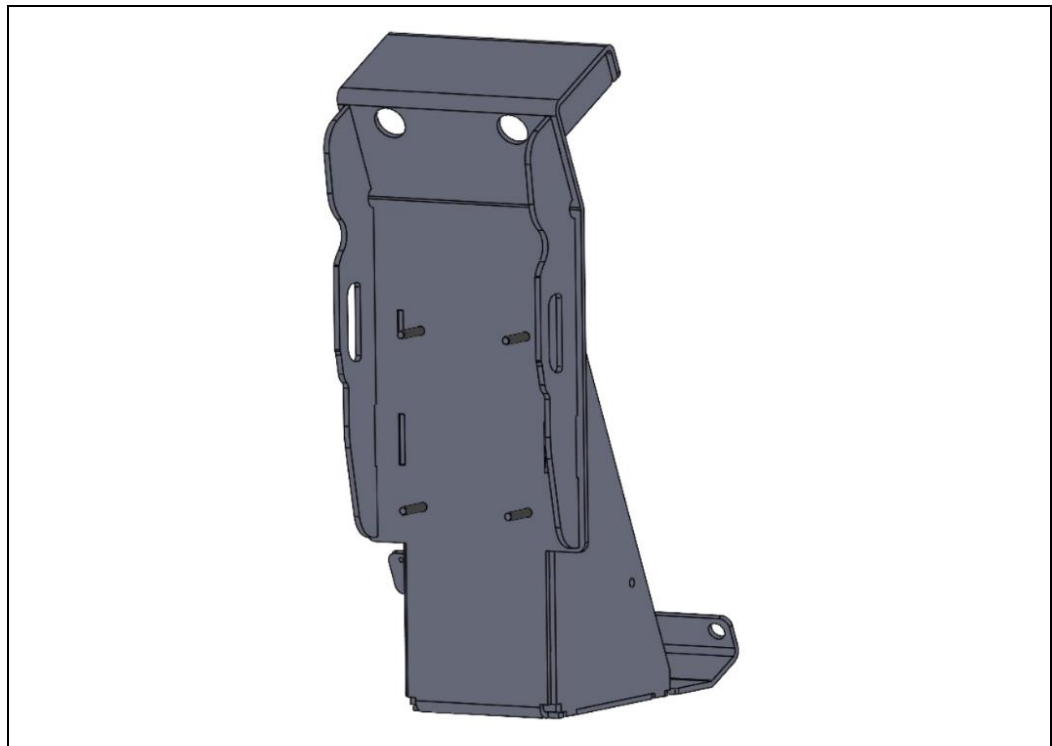

Fig.: 14 : Bracket for the VN2020 series (example variant)

4.3.4 Header pipe

Schaller Automation uses tried-and-tested hydraulic components for its installation kits for sampling and transporting atmosphere containing oil mist. Only pipes (tubes) in accordance with DIN EN 10305-4 and fittings in accordance with EN ISO 8434-1 are used. The combination of all horizontally connected signal pipes is also referred to as the “header pipe”.

The pipes are always customised to the engine geometry or the available installation space and are preferably supplied with straight design. Depending on requirements, angled piping is also available, to customer specifications.

Cutting rings and union nuts for connecting multiple pipes are supplied pre-assembled as screw fittings or enclosed loose with the installation kit, depending on the application or customer requirements.

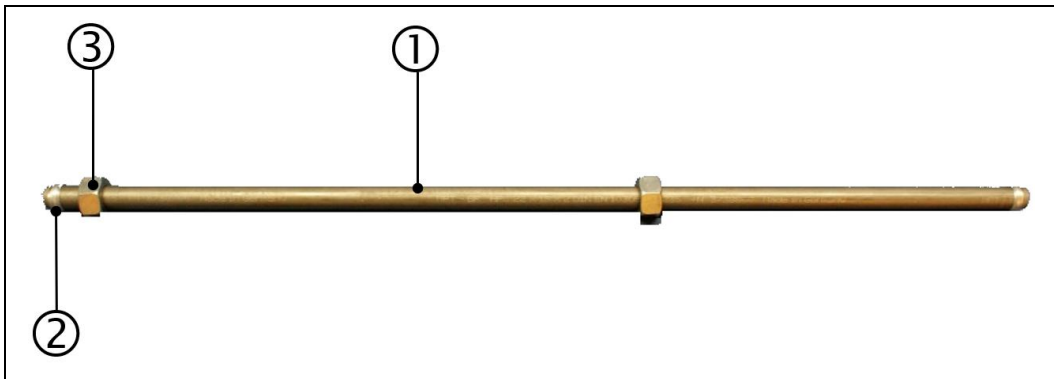

Fig.: 15 : Pipe with screw fitting, installation kit for VN2020 series

- 1: Header pipe (straight)
- 2: 2x cutting rings
- 3: 2x union nuts

4.3.5 Engine wall connection (EWC) and sampling funnel

An engine wall connection essentially consists of two main components: the screw connection body (①) and an sampling funnel (②).

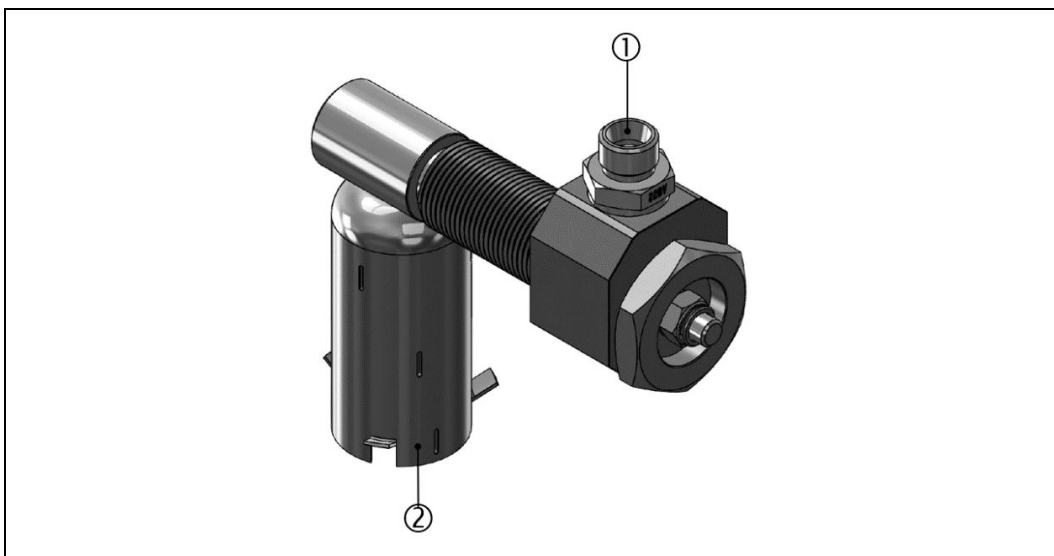

Fig.: 16 : Engine wall connection (EWC) for the VN2020 series

- 1: Screw connection body
- 2: Sampling funnel

The oil mist-containing atmosphere is taken in via the sampling funnel and, at the same time, splash oil is prevented from getting into the header pipes by an integrated labyrinth geometry. Precipitated oil can permanently block the header pipes and ultimately prevent the test medium from being taken in continuously.

The fitting body allows for angular adjustment to accommodate the intake lines and forms the connection between the header pipes, intake lines and the crankcase.

Schaller Automation offers engine wall connections in various versions and specifically to match the engine geometry.

4.3.6 Siphon block

The siphon block is the alternative in the installation kit to the engine wall connection (EWC). If necessary, this is used instead of the engine wall connection (EWC) (Fig. 11, Pos.3) if the standard drainage concept using the pipe siphon (Fig. 10, Pos.4) cannot be used for reasons associated with the application.



Fig.: 17 : Siphon block for the VN2020 series

4.3.7 Hose lines

As an alternative to the rigid sampling and exhaust air lines, flexible hose lines can also be used, as shown in the figure below. The core of these lines consists of a hydraulic hose, with an additional sheath of galvanised wire mesh.



Fig.: 18 : Flexible hose line for the VN2020 series

The hose lines are available with certificates from classification societies and authorities. The certificates can be downloaded from Schaller Automation's homepage (www.schaller-automation.com).

4.3.8 Pipe siphon



Fig.: 19 : Pipe siphon, VN2020 series

1: Pipe siphon

2: Screw fitting

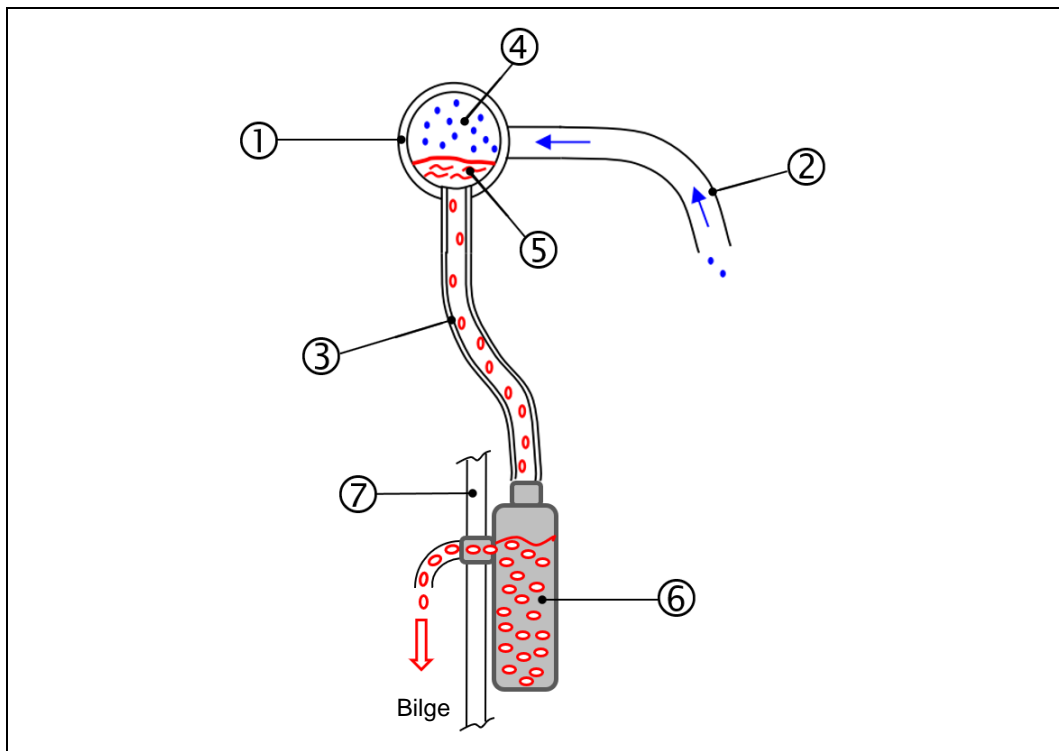

Fig.: 20 : Functional principle of oil drainage via pipe siphon, VN2020

1: Header pipe

2: Aspirated crankcase atmosphere

3: Intake pipe for the pipe siphon

4: Crankcase atmosphere (header pipe)

5: Precipitated oil (flows into the pipe siphon)

6: Pipe siphon

7: Engine wall

The pipe siphon has the task of draining the precipitated oil in the header pipes before it completely closes or constricts the header pipes.

As already described in detail in Section 4.3.5 ⇒ Section 4.3.5 Engine wall connection (EWC) and sampling funnel, precipitated oil can permanently block the header pipes and thereby prevent the test medium from being taken in continuously.

4.3.9 Remote Indicator II for VISATRON® VN2020/VN2020 EX (optional)



NOTE

It is recommended that the VISATRON® VN2020/VN2020 EX system is used with a remote monitoring system (the Remote Indicator II) to monitor the oil mist concentration and the status of the VISATRON® VN2020/VN2020 EX system from a safe location in accordance with IACS UR M10.



Fig.: 21 : Remote monitoring system (Remote Indicator II) for VISATRON® systems (optional)

4.3.10 Setting the device sensitivity

The VISATRON® VN2020/VN2020 EX system determines the oil mist concentration using an optical measuring track in the measuring head of the device. The values are calculated as the percentage for “opacity”. 100% opacity means that no light penetrates through the oil mist sample. This is equivalent to the light hitting a white (= opaque) surface.

IACS UR M67 requires an oil mist alarm at 5% of the lower explosive limit (LEL). The LEL corresponds to an oil mist concentration of 47 mg/l in the air at a temperature of 25 °C. This means that the oil mist detector must output an oil mist alarm at approx. 2.5 mg/l.

The sensitivity is set on the device via a USB connection with the measuring head. This procedure is described in detail in Section 7.1 ⇒ Section 7.1 Parameter settings, VISATRON® VN2020/VN2020 EX.

The following table illustrates the possible sensitivity settings on the device:

Sensitivity setting	Alarm-triggering oil mist concentration [mg/l]
1	0.55
2 (Default factory setting)	0.7
3	0.9
4	1.1
5	1.4
6	1.8
7	2.5

Table 9 : Setting the device sensitivity

4.4 Intended use

When used on large engines that have mandatory explosion protection classification, an oil mist detector with corresponding ATEX or IECEx approval must be used in potentially explosive atmospheres.

⇒ Section 3.1 Marking and type description

The task of the oil mist detector is to prevent explosions in the crankcase of large engines caused by a high concentration of oil mist, such as can occur in the event of bearing damage within a large engine.

The oil mist detector therefore must only be used for the detection of oil mist in crankcases and to protect against oil mist explosions on large engines (diesel, gas and dual fuel).

When used on large engines with mandatory approval by maritime classification societies, an oil mist detector (⇒ Section 17 EC Declaration of Conformity) with corresponding class approval must be used.

The safety instructions are mandatory and must be observed!

Improper handling or other use of the device is considered to be use not as intended and therefore constitutes an unapproved mode of operation. The manufacturer is not liable for any resulting damage.

4.5 Foreseeable misuse



NOTE

Applications and actions not referred to or described in this manual are not allowed!

- ▶ Installing the VISATRON[®] VN2020/VN2020 EX without using the sampling funnels is not allowed.
- ▶ Installation and maintenance of the VISATRON[®] VN2020/VN2020 EX by unauthorised persons is not allowed.
- ▶ Using the VISATRON[®] VN2020 without ATEX or IECEx approval in potentially explosive atmospheres is not allowed.
- ▶ Installing components **other than** as shown in this operating manual and the relevant installation kit drawing approved by the engine manufacturer and the oil mist detector manufacturer is not allowed.

4.6 Descriptions of the controls and indicators

4.6.1 Controls and indicators, VISATRON[®] VN2020/ VN2020 EX

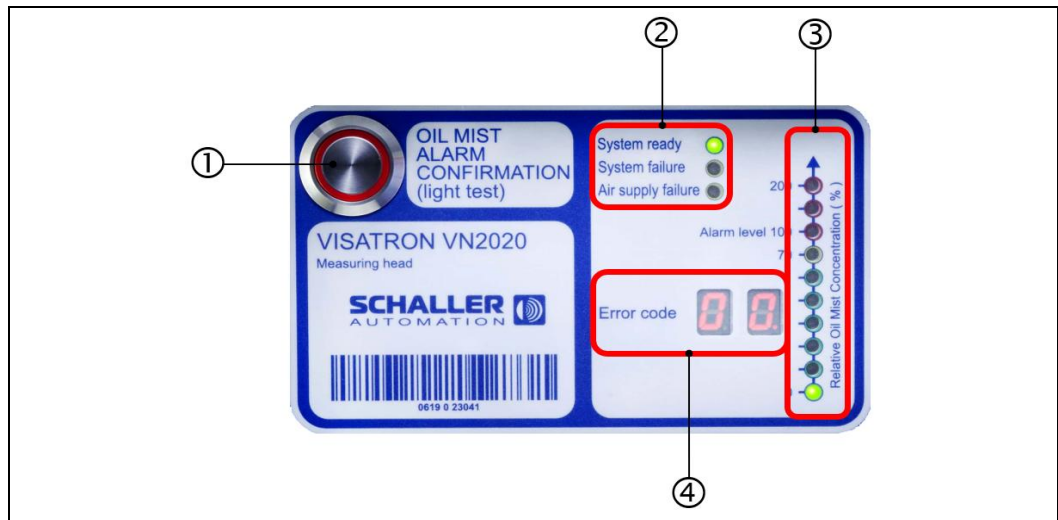

Fig.: 22 : Controls and indicators, VN2020

- | | |
|---|------------------------|
| 1: Confirmation button | 2: System status |
| 3: Display; relative oil mist concentration | 4: Display, error code |

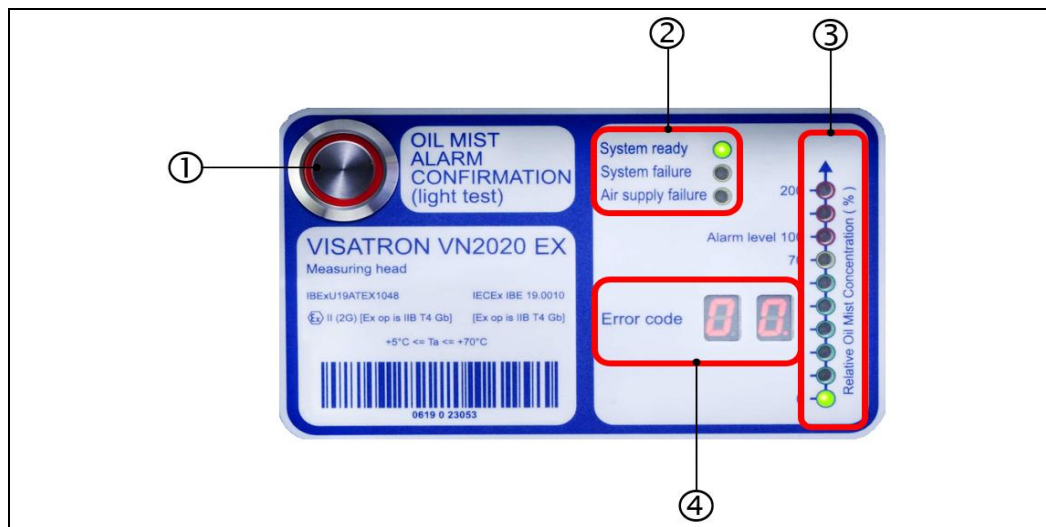

Fig.: 23 : Controls and indicators, VN2020 EX

- | | |
|---|------------------------|
| 1: Confirmation button | 2: System status |
| 3: Display; relative oil mist concentration | 4: Display, error code |

4.6.1.1 Fault indicators, VISATRON[®] VN2020/VN2020 EX

As per the figures above, system faults are displayed using the following indicators:

- | |
|------------------------|
| 2: System status |
| 4: Display, error code |

System faults are described in detail in Section 10 “Troubleshooting”. → Section 10 Error diagnosis and troubleshooting

5 Transport and storage

5.1 Unpacking and items included in delivery

When you receive the VISATRON[®] VN2020/VN2020 EX oil mist detector, check the whole delivery to ensure that it contains all the components. Schaller Automation provides a detailed parts list for you to use for this purpose.



NOTE

Dispose of the packaging materials in accordance with your local disposal regulations in the containers provided for this purpose.

5.2 Transport

The delivery is ex works in a ready-to-use condition. Delivery is made in accordance with the terms of the contract.

Check the delivery immediately on receipt for any transport damage.



CAUTION

Damaged components can cause damage to machinery and persons.

- ▶ Make sure immediately that the delivery is correct, complete and undamaged. Report any visible transport damage to the responsible transport company immediately.



CAUTION

Damage to the device from improper transport

- ▶ Avoid shocks, vibrations and collisions with other objects by handling the device slowly and in a controlled manner.
- ▶ A collision or falling of the device may cause damage to the internal high-precision components. In such cases, we recommend no longer using the device.



5.3 Storage conditions before starting up

The maximum storage period for the VISATRON[®] VN2020/VN2020 EX oil mist detector is 12 months after receipt of goods in the original packaging.

- ▶ Store the device in a place that meets the following conditions:
 - The room is closed (dry and free from dust)
 - There is no exposure to wind or rain
 - There is no exposure to flammable, volatile or corrosive gases or dust
 - There is no exposure to vibrations
 - The place is stable and free of hazards

Storage temperature range	-25 °C to max. 50 °C
Relative humidity [RH]	< 85% and avoiding condensation

Table 10 : Storage conditions before starting up



 CAUTION
<p>Incorrect storage can damage the device.</p> <ul style="list-style-type: none"> ▶ Keep the storage period for the device to a minimum. ▶ Keep the device in its original packaging. ▶ If stored for a longer period, check the condition of the device regularly and carry out corrosion protection measures, if necessary. ▶ Note the warranty period under the General Terms & Conditions

6 Assembly and installation



! WARNING	
	<ul style="list-style-type: none"> ▶ Failure to comply with the safety instructions may result in major damage to property or the environment and in serious injury or death. ▶ Familiarise yourself with the basic safety instructions before starting assembly. ⇒ Section 2.4 Basic safety instructions



NOTE	
	<ul style="list-style-type: none"> ▶ Observe the environmental conditions for assembling the device. ⇒ Section 3.4.4 Environmental conditions

6.1 Preparatory steps by the customer



NOTE	
	<ul style="list-style-type: none"> ▶ For installation and operation of the oil mist detection system, the following must be provided by the customer at the installation site: <ul style="list-style-type: none"> <input checked="" type="checkbox"/> a supply line for compressed air; <input checked="" type="checkbox"/> a supply line for the electrical power supply; <input checked="" type="checkbox"/> a supply line to transfer the signals of the relay contacts; <input checked="" type="checkbox"/> a bus line for CANopen communication (optional); and <input checked="" type="checkbox"/> a bus line for RS485 communication (optional) for Remote Indicator II or for Modbus communication ⇒ For details, see Section 3.4.1. Mechanical interfaces (M) ⇒ For details, see Section 3.4.2. Electrical interfaces (E)

6.1.1 Establishing the compressed air supply

The compressed air supply must be provided by the customer and have a compressed air quality according to ISO 8573-1:2010 [6:4:4] up to the pressure regulator unit or installed at connection P1. The compressed air supply may vary between 2-14 bar for optimum operation.



! WARNING	
	<p>Mild to severe bruising when handling compressed air Risk of injury from whipping of the compressed air hose line.</p> <ul style="list-style-type: none"> ▶ Before connecting the supply pressure, check the applied system pressure. ⇒ Section 3.4.3 Pneumatic interfaces (P)

6.1.2 Establishing the electrical power supply

The electrical power supply must be provided by the customer up to the device:

- Power supply: 18 Volt to 31.2 Volt DC, max. 2 A
- Nominal voltage: 24 Volt DC



DANGER

Electrical hazards

- ▶ Before connecting the electrical supply cables to the connecting boxes of the VISATRON[®] VN2020/VN2020 EX, they must be disconnected from the power supply first.
- ▶ Before starting work, disconnect the VISATRON[®] VN2020/VN2020 EX from the power supply or make sure that the housing is safely earthed.



6.1.3 Preparation for signal transfer from the alarm contacts

Signal transfer must be established by the customer using a suitable standard cable.

⇒ For details, see Section 3.4.2. Electrical interfaces (E)

6.1.4 Preparation for CANopen communication (optional)

Signal transfer must be established by the customer using the recommended bus cable.

⇒ For details, see Section 3.4.2. Electrical interfaces (E)

6.1.5 Preparation for RS485 and Modbus communication (optional, e.g. for Remote Indicator II)

Signal transfer must be established by the customer using the recommended bus cable.

⇒ For details, see Section 3.4.2. Electrical interfaces (E)

6.2 Setting up



NOTE

Observe the ambient conditions when setting up. (E.g. humidity, vibration, etc.)

⇒ Section 3.4.4 Environmental conditions

- ▶ The VISATRON[®] VN2020/VN2020 EX oil mist detector may only be installed by qualified or trained personnel!
- ▶ Suitable electrical supply connections must be available at the site.
⇒ Section 6.1 Preparatory steps by the customer
- ▶ Do not operate the VISATRON[®] VN2020/VN2020 EX oil mist detector in an elevated electromagnetic environment. (Outside standardised limit values)
- ▶ Observe the safety distances when setting up. The VISATRON[®] VN2020/VN2020 EX oil mist detector (device, engine wall connection, siphons, etc.) must remain accessible for maintenance work.
- ▶ Do not operate the VISATRON[®] VN2020/VN2020 EX oil mist detector with increased vibrations or outside the allowed limit values.
⇒ Section 3.4.4 Environmental conditions

- ▶ If the oil mist detector is operated in explosion-proof areas, the relevant safety instructions must be observed.
⇒ Section 2.4.1 Safety instructions for potentially explosive atmospheres

6.3 Assembling the system components

CAUTION



Safe and correct assembly of the device

- ▶ For assembly, read the operating manual and other documents accompanying the product with care and keep them in a suitable place for future reference.

NOTE



Personal protective equipment

Operating the device or working on the device without protective equipment may result in serious injury. For the workplace PPE, the following protective equipment must be used:

- ▶ DIN EN 388:2016 Protective gloves against mechanical risks, 2341X, and DIN EN 407:2004 Protective gloves against thermal risks, X1XXXX
- ▶ Safety glasses in accordance with DIN EN 166 or DIN EN 170
- ▶ Safety helmet in accordance with DIN EN 397 and DIN EN 50365

DANGER



Hazards during assembly

There is a risk of serious injury, including death, from explosion in the crankcase as a result of incorrect assembly or installation.

- ▶ You may only assemble the oil mist detector when the engine is switched off and the system has been disconnected from the power supply first! The compressed air supply to the oil mist detector must also be switched off first.
- ▶ Before assembly, the housing of the VISATRON[®] VN2020/VN2020 EX oil mist detector must be earthed.



WARNING



Failure to comply with the safety instructions may result in major damage to property or the environment and in serious injury or death.

- ▶ Familiarise yourself with the basic safety instructions before starting assembly.
⇒ Section 2.4 Basic safety instructions

6.3.1 Class-compliant assembly and installation according to IACS Unified Requirement UR M10

The oil mist detector has been developed and approved by SCHALLER AUTOMATION in accordance with the mandatory IACS UR M10 M67 requirement (sensitivity of the oil mist detector and determination of the oil mist concentration).



NOTE

Compliance with IACS requirements

- ▶ The IACS Unified Requirement UR M10 specifies that the installation drawings for the oil mist detector must be approved by the engine builder and SCHALLER AUTOMATION. The oil mist detector is installed exclusively in accordance with these drawings and the information provided in this operating manual.

6.3.2 Installing the oil mist detector with pre-assembled bracket



DANGER

Accumulation of dangerous gas concentration at the oil mist detector, when mounted on dual-fuel or gas engines

There is a risk of serious injury, including death, from hazardous accumulation of gas concentrations in the oil mist detector as a result of incorrect assembly or installation. The following instructions must therefore be observed, in particular when installing VN2020 EX:

- ▶ The oil mist detector must **not** be installed in a recess that could allow gas to accumulate!
- ▶ The oil mist detector must **not** be fitted with an enclosure by the customer!



WARNING

Impairment of function and operation of the device

- ▶ The oil mist detector must not be painted, varnished or otherwise altered.



DANGER

Risk of injury from overhead loads

- ▶ A suitable means of transport must be used for assembly and for transport to the assembly site. The oil mist detector can be attached to the crane via the lifting eye nut on the protective cover. Suitable lifting equipment must be used for transport.
- ▶ Do not step into the area of rotation or under the load.
- ▶ Carefully secure the load before assembly.
- ▶ Use personal protective equipment. ⇒ *Section 2.4 Basic safety instructions*

Start by attaching the bracket (②) to the engine wall (①) using suitable bolts (not included in the delivery) and torque as shown in the figure below, or to the mounting holes provided for this purpose according to the customer drawing.

Then mount the oil mist detector (③) on the pre-assembled, engine-specific bracket in accordance with the supplied mounting kit (④) and customer drawing, as shown in the figure below.

NOTE



- ▶ The recommended side for mounting on the engine is opposite to the side of the explosion protection valves.

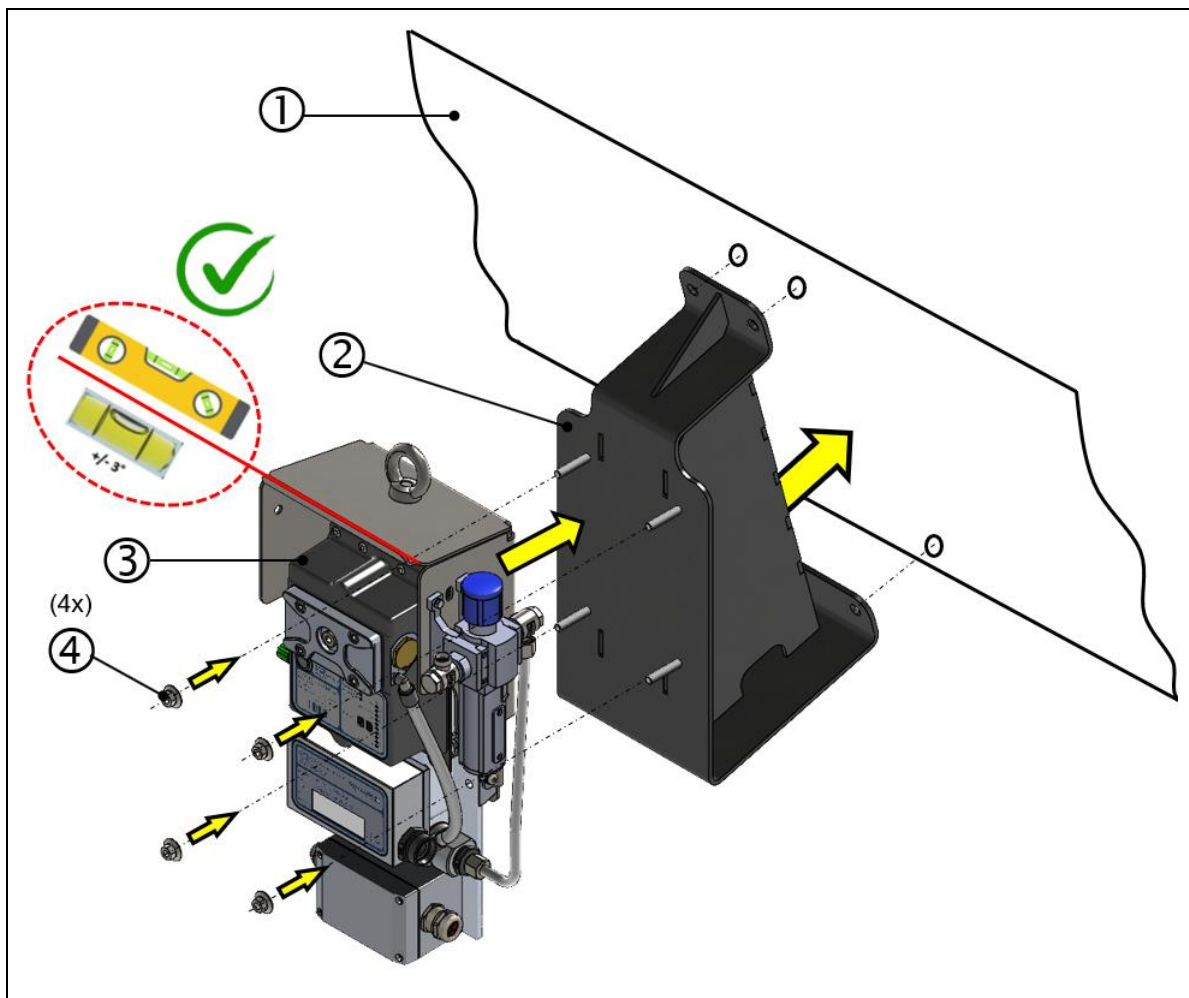

Fig.: 24 : Installing VN2020 with bracket and protective cover

1: Engine wall

2: Bracket (customer-specific)

3: VISATRON® VN2020

4: 4 pcs. ROMOB M8 St nuts (included in delivery)

NOTE

Premature contamination of the oil mist detector



- ▶ The allowed assembly tolerance is +/- 3 degrees deviation from the horizontal alignment.

6.3.3 Installing the oil mist detector without bracket



DANGER

Accumulation of dangerous gas concentration at the oil mist detector, when mounted on dual-fuel or gas engines

There is a risk of serious injury, including death, from hazardous accumulation of gas concentrations in the oil mist detector as a result of incorrect assembly or installation. The following instructions must therefore be observed, in particular when installing VN2020 EX:

- ▶ The oil mist detector must **not** be installed in a recess that could allow gas to accumulate!
- ▶ The oil mist detector must **not** be fitted with an enclosure by the customer!



WARNING

Impairment of function and operation of the device

- ▶ The oil mist detector must not be painted, varnished or otherwise altered.



DANGER

Risk of injury from overhead loads

- ▶ A suitable means of transport must be used for assembly and for transport to the assembly site. The oil mist detector can be attached to the crane via the lifting eye nut on the protective cover. Suitable lifting equipment must be used for transport.
- ▶ Do not step into the area of rotation or under the load.
- ▶ Carefully secure the load before assembly.
- ▶ Use personal protective equipment. → Section 2.4 Basic safety instructions

As shown in the figure below, the oil mist detector with protective cover (①) can alternatively be attached directly to the engine wall via four through-holes with 9 mm diameter or to a bracket with M8 nuts (②) prepared in advance by the customer, provided that the engine peripherals allow for this.



NOTE

- ▶ The recommended side for mounting on the engine is opposite to the side of the explosion protection valves.



NOTE

Premature contamination of the oil mist detector

- ▶ The permissible installation tolerance, as per the following figure, is +/- 3 degrees deviation from the horizontal alignment.

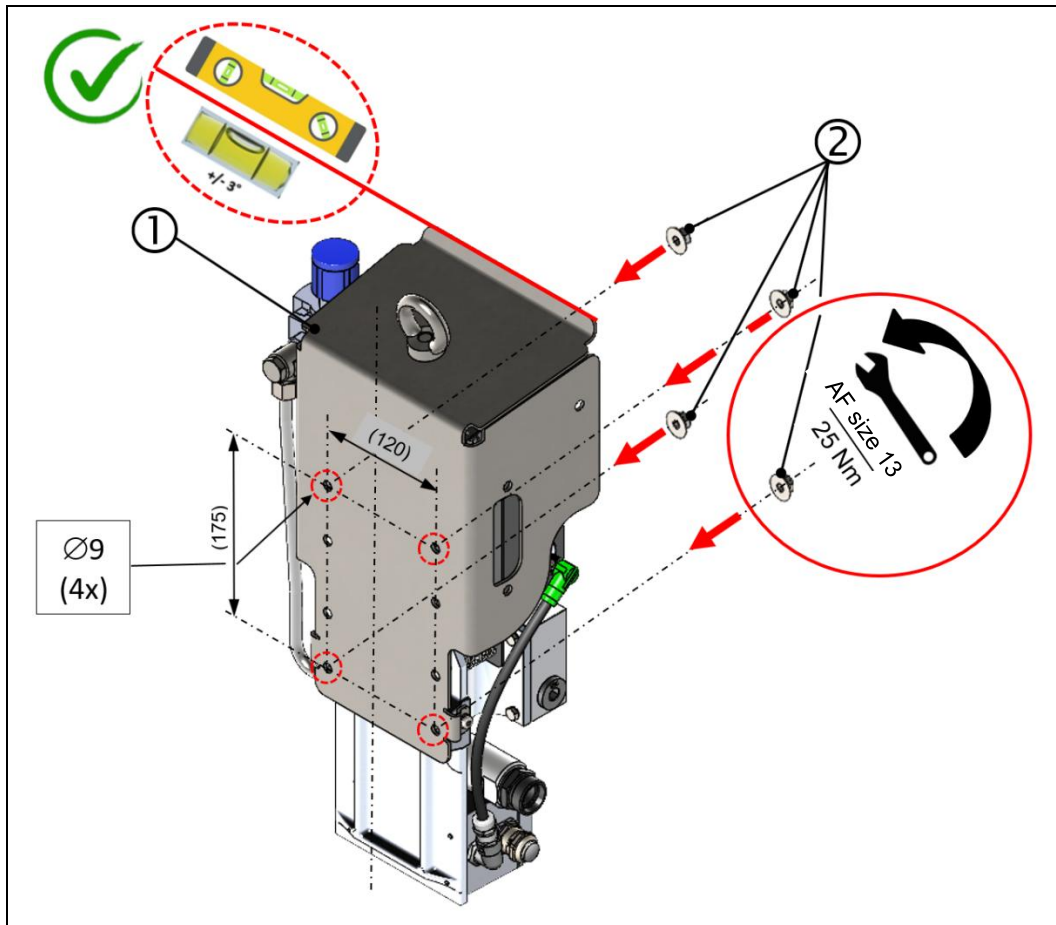

Fig.: 25 : Installing VN2020 without bracket and with protective cover (rear view)

1: VISATRON® VN2020

2: 4 pcs. ROMOB M8 St nuts (included in delivery)

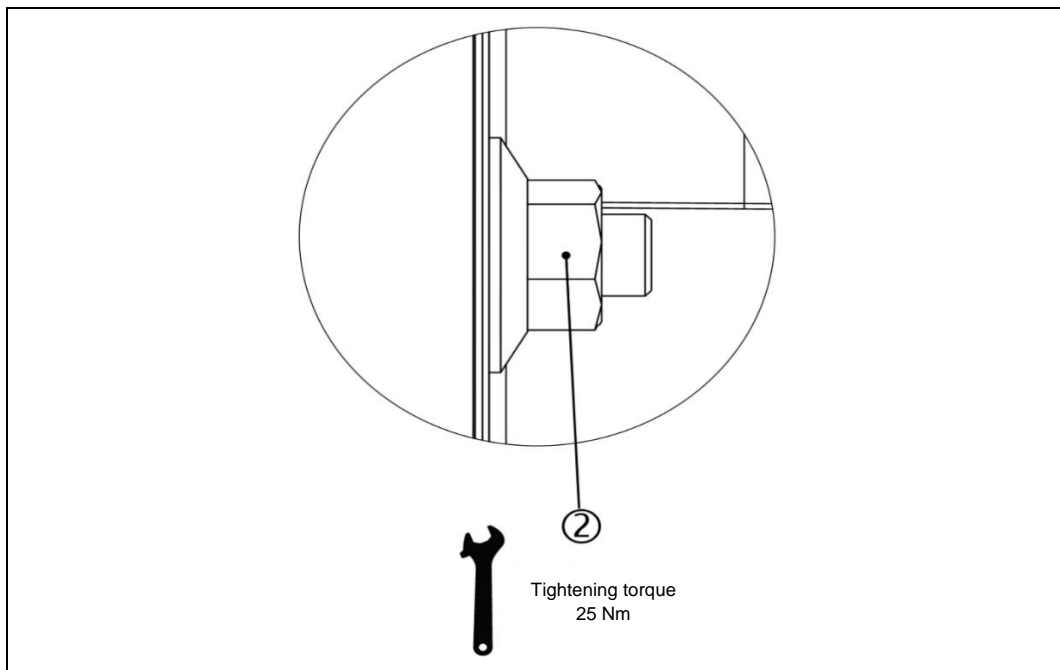

Fig.: 26 : ROMOB M8, installed

2: 4 pcs. ROMOB M8 St nuts (included in delivery)

6.3.4 Installing the engine wall connection and sampling funnel

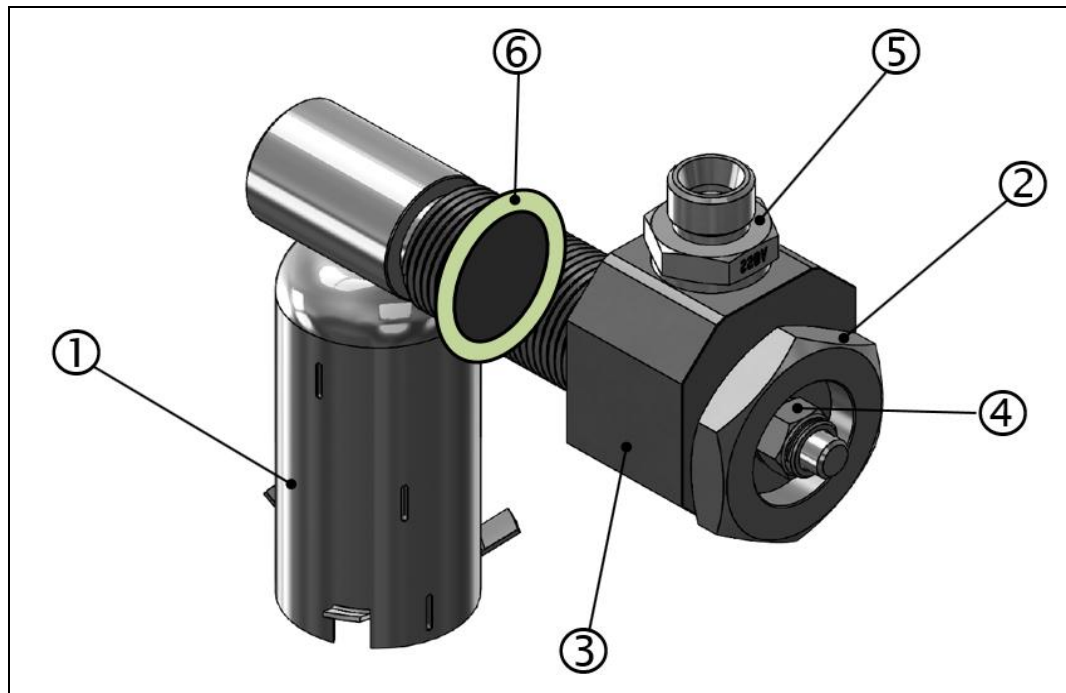

Fig.: 27 : Engine wall connection (EWC)

- | | |
|---|----------------------------|
| 1: Sampling funnel | 2: Hollow union bolt G3/4" |
| 3: Engine wall connection (EWC) housing | 4: Lock nut M8 |
| 5: Throttle fitting | 6: Seal M27, oil-resistant |

Part number: 270354 (standard)

Required tools:

- ▶ Socket spanner, size 13 (4)
- ▶ Open spanner, size 19 (5, top)
- ▶ Open spanner, size 22 (5, bottom)
- ▶ Open spanner, size 41 (2)
- ▶ Open spanner, size 46 (3)



⚠ DANGER

Damage to the sampling funnel after the installation process

- ▶ The sampling funnel must not come into contact with rotating or moving parts after it is installed.

Premature contamination of the oil mist detector by splash oil

- ▶ The intake position of the sampling funnel must be outside areas with direct splash oil.

Explosion in the crankcase

There is a risk of serious injury, including death, from explosion in the crankcase as a result of incorrect assembly of the engine wall connection.

- ▶ Loosening or removing the intake line from the engine wall connection is **only** allowed when the engine is switched off, as an explosive atmosphere can escape from the engine and lead to a risk of explosion.

NOTE

Premature contamination of the oil mist detector

- ▶ The sampling funnels must be installed according to the customer drawing and always aligned vertically and with the opening pointing towards the bottom of the crankcase.
- ▶ The allowed assembly tolerance is +/- 3 degrees deviation from the horizontal alignment.



DANGER

Blockage of the sampling funnel

- ▶ Constant flooding of the sampling funnel with splash oil (caused by the rotating crankshaft) negatively affects monitoring of the applicable crank segment and must always be avoided.

Recommended installation for the engine wall connection, as shown in the figure below:

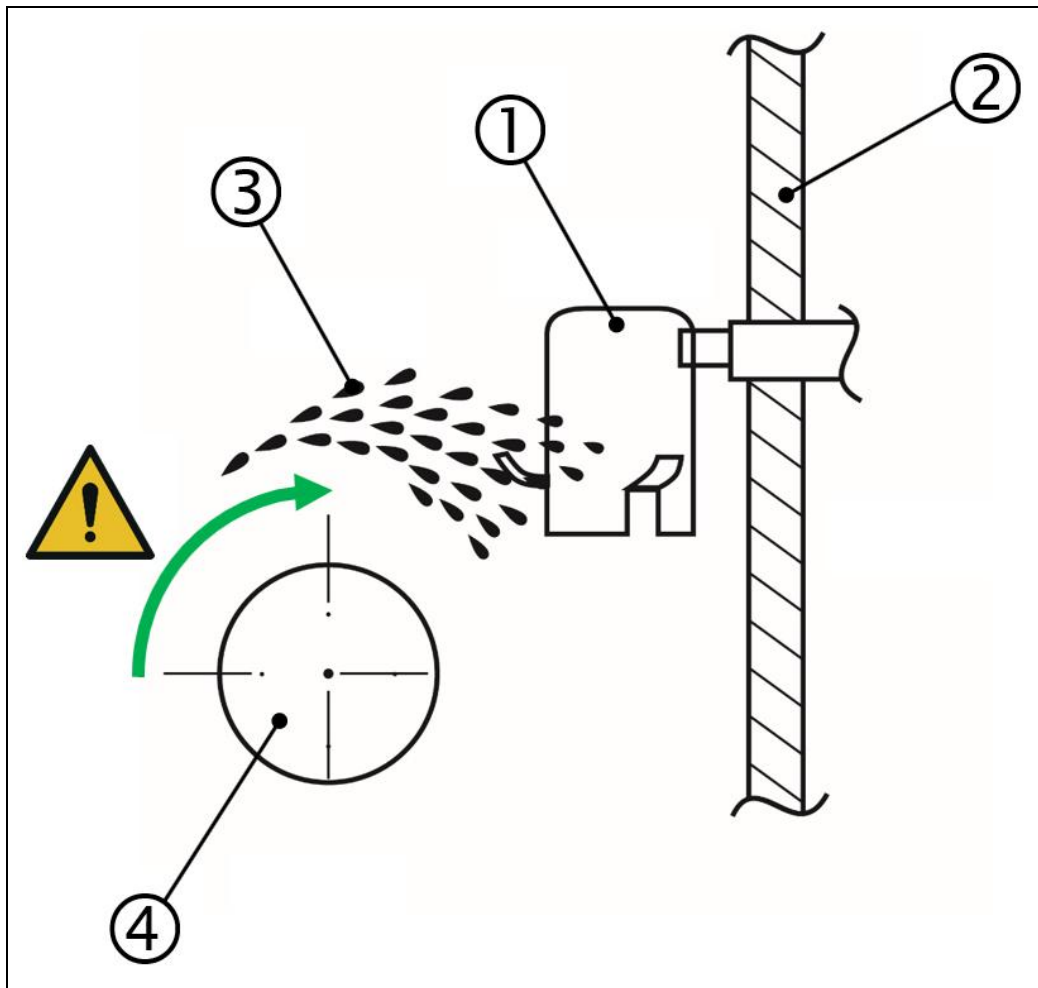
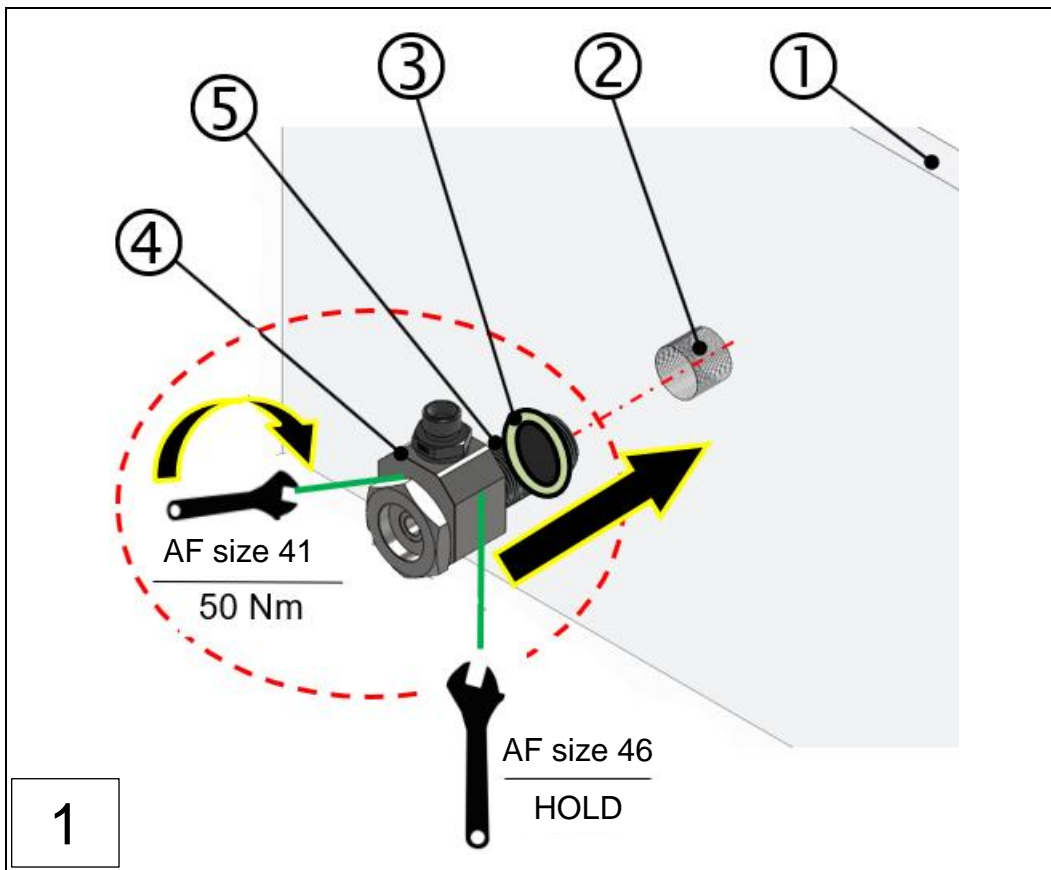

Fig.: 28 : Recommended inst. for the engine wall connection (view from the crankshaft end)

1: Sampling funnel
3: Splashing oil

2: Engine wall
4: Rotating crankshaft



- 1: Engine wall
- 3: Seal M27, oil-resistant
- 5: Threadlocker (Loctite 243)

- 2: Screw-in thread: G3/4" or M27x1.5
- 4: Screw connection body

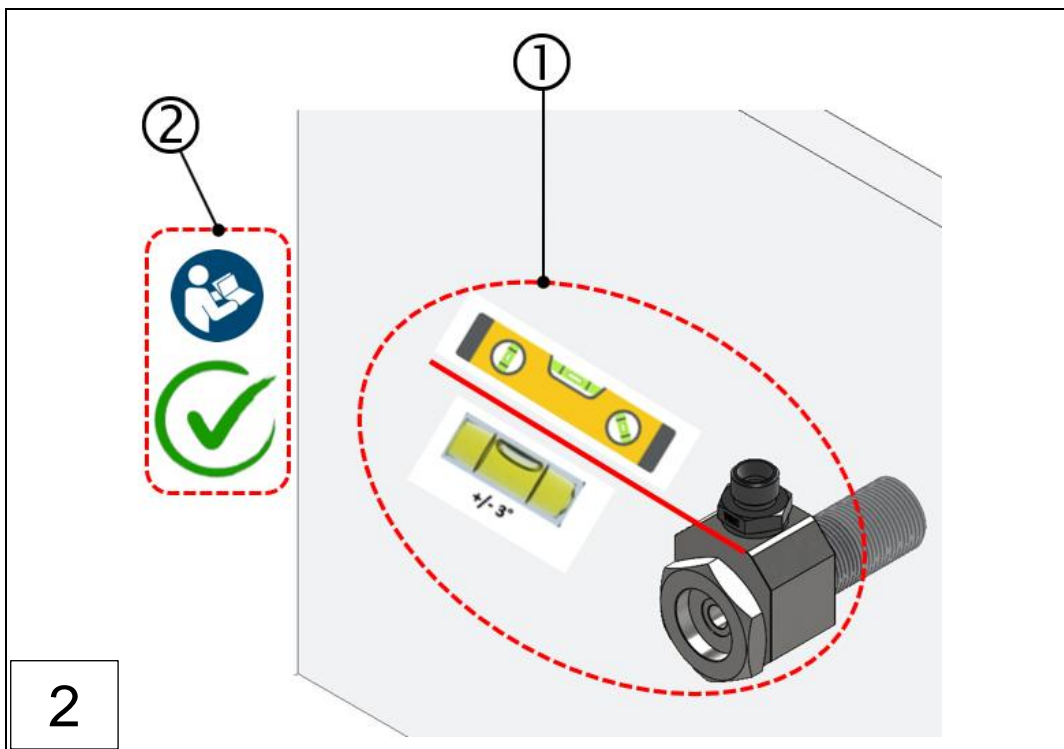

- 1: Screw fitting body (in final position)

- 2: Manual (to be followed)

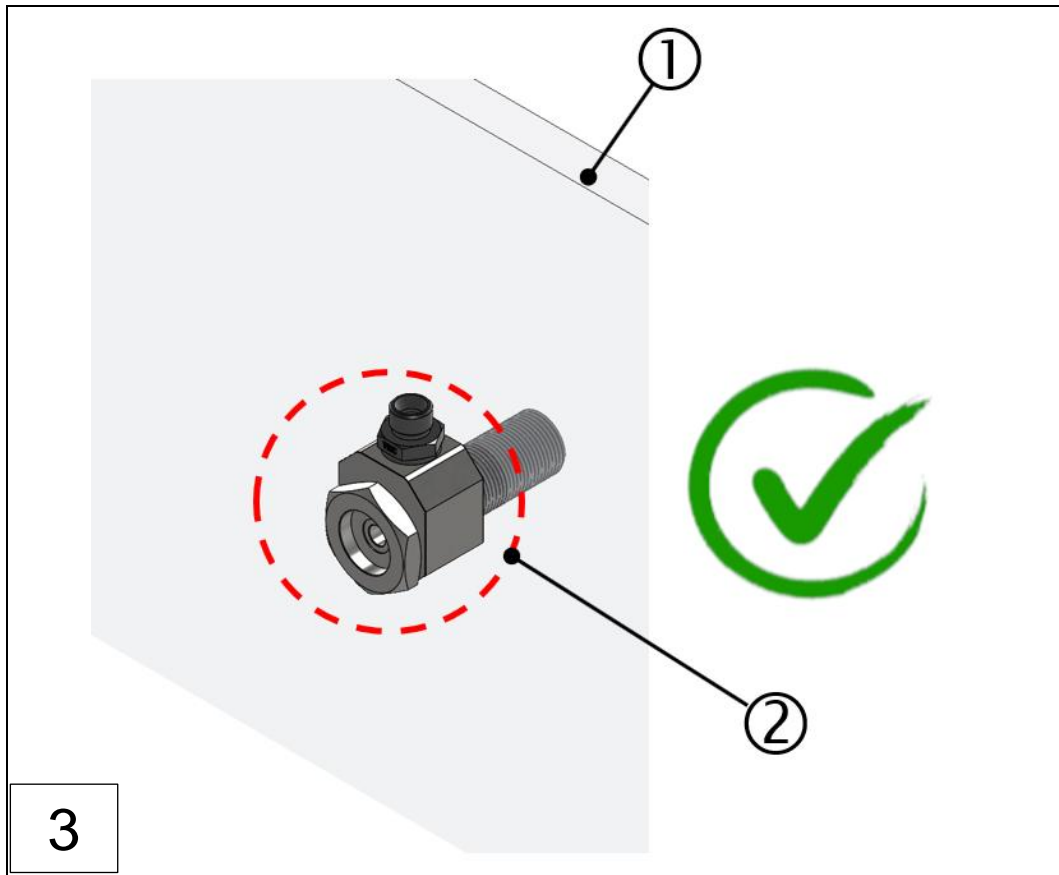

1: Engine wall

2: Screw fitting body (in final position)

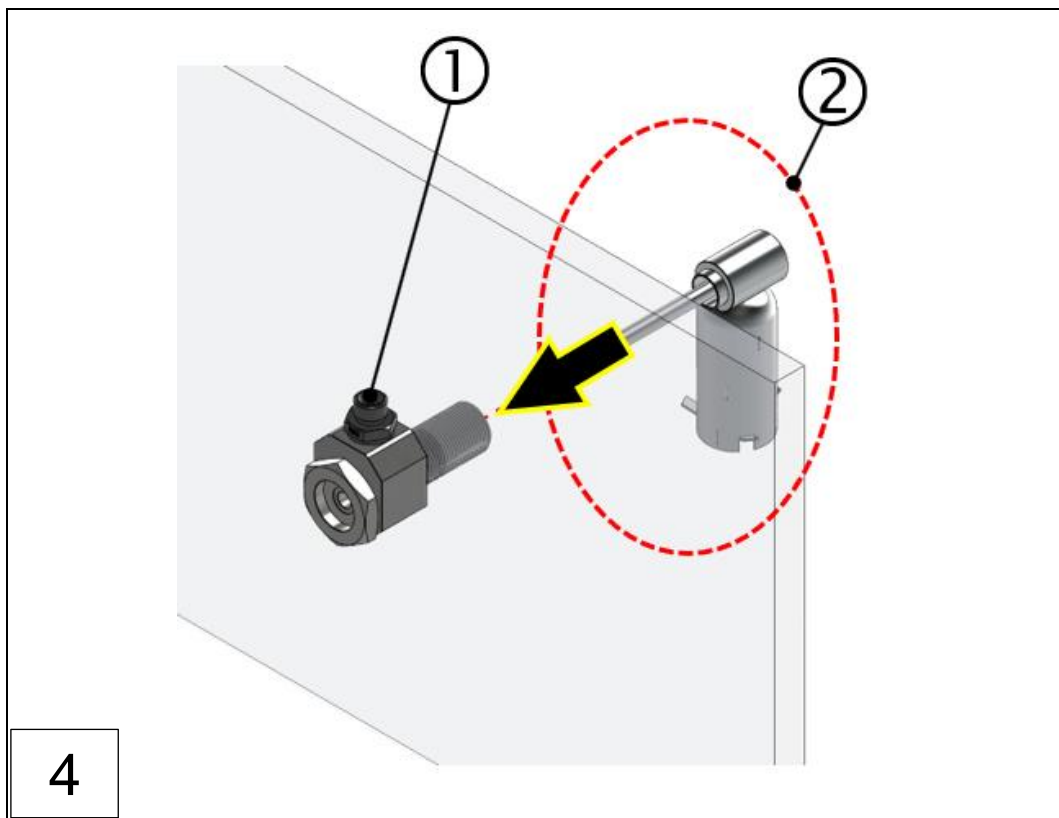

1: Screw connection body

2: Sampling funnel (installed)

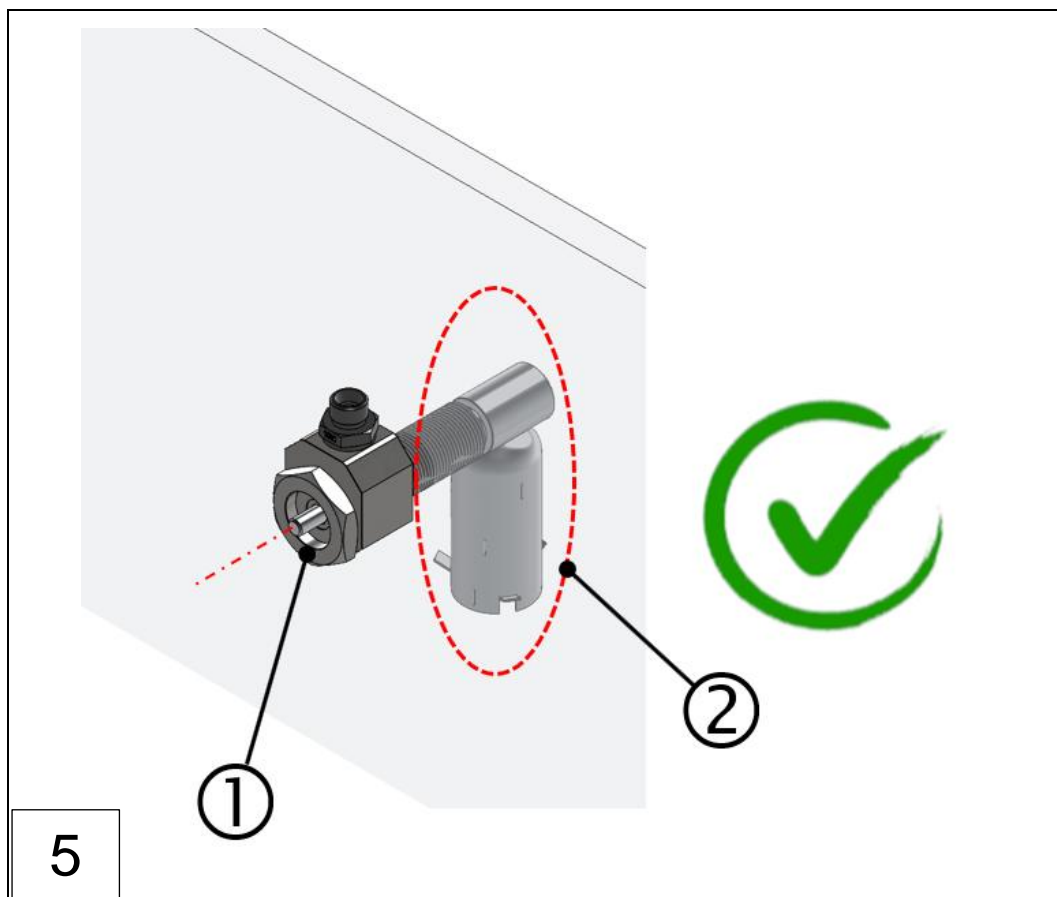

1: Screw connection body

2: Sampling funnel

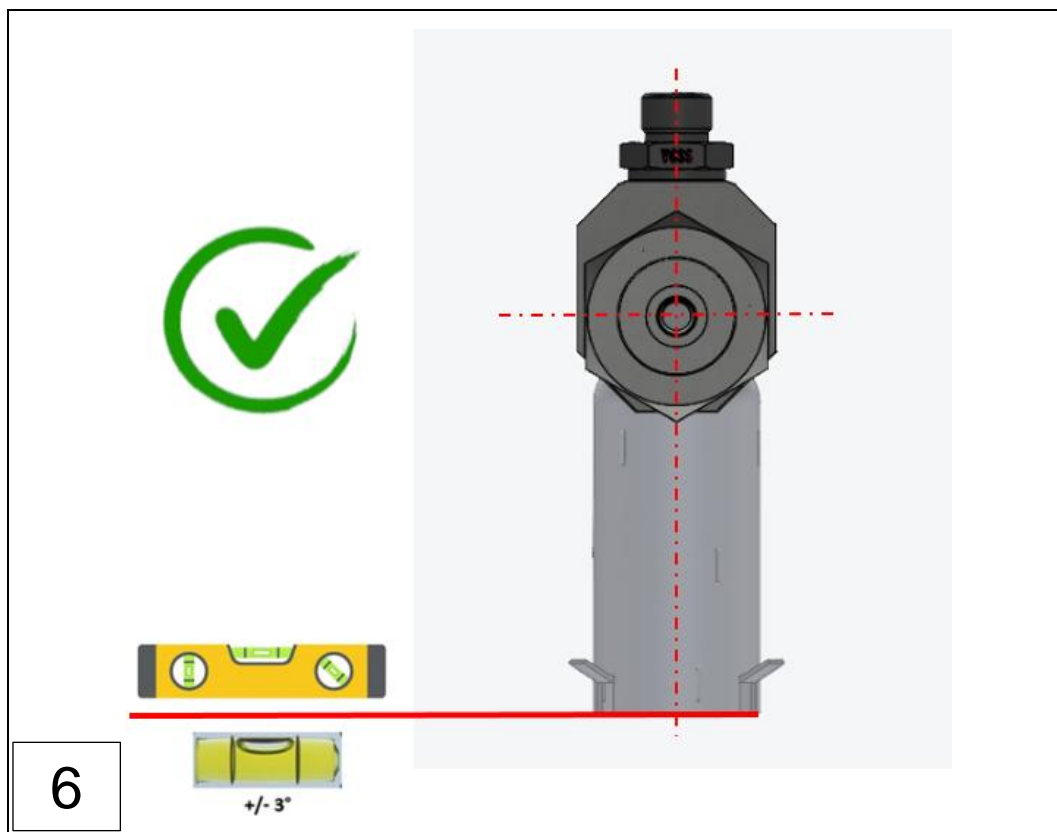

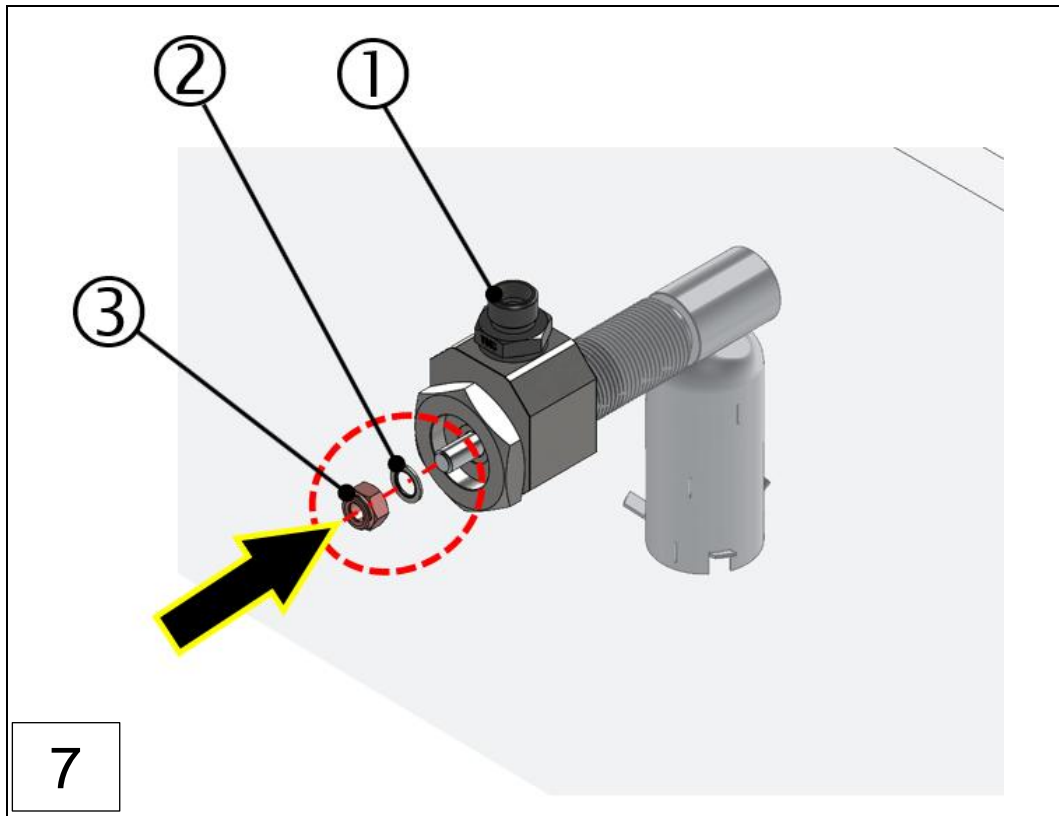

1: Screw connection body
2: Lock nut

2: Sealing disc

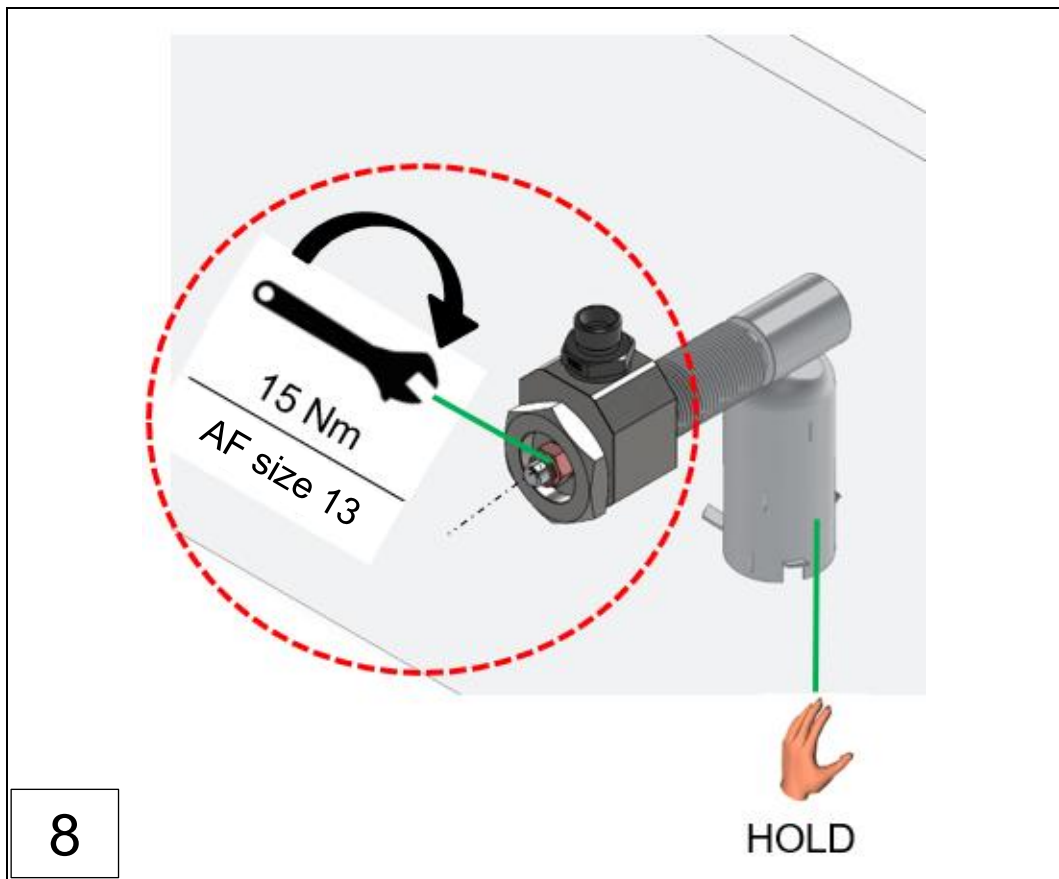

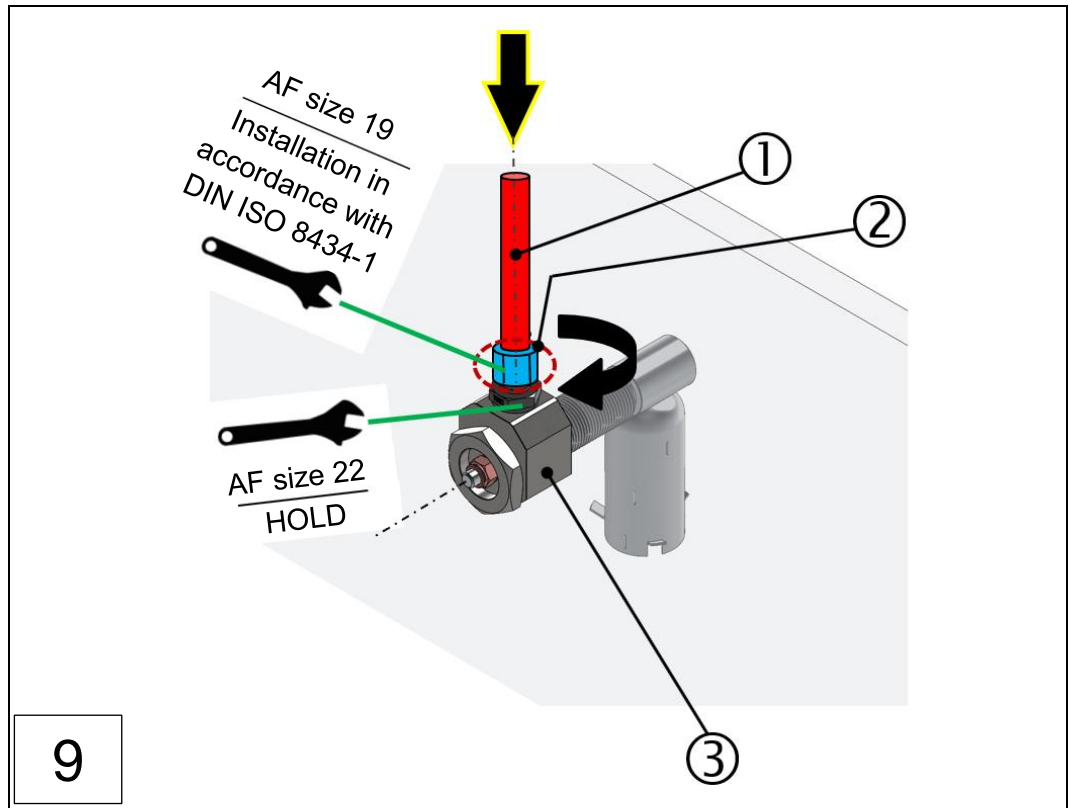

Fig.: 29 : Installing the engine wall connection for the VN200 (installation steps 1-9)

- 1: Sampling hose/intake pipe
- 2: Cutting ring fitting (2-part)
- 3: Engine wall connection

6.3.5 Installing the siphon block assembly

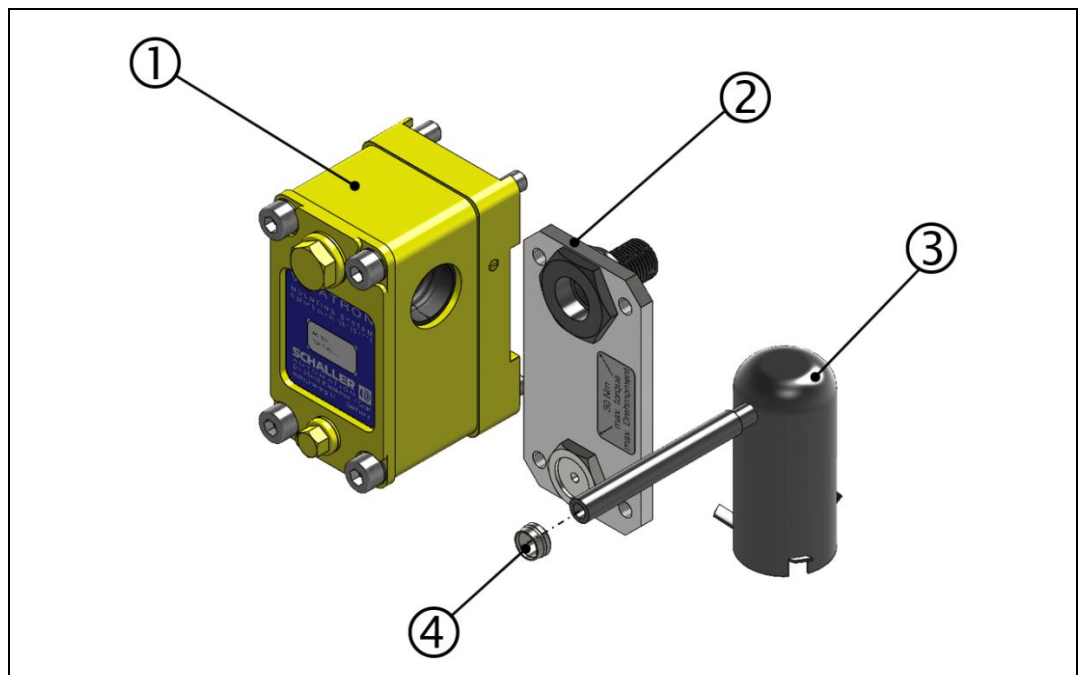

Fig.: 30 : Siphon block assembly

- 1: Complete siphon block (without measuring connection)
- 2: Connecting unit 03
- 3: Sampling funnel
- 4: Cutting ring

Part numbers:

- ▶ 150260 – Siphon block (standard)
- ▶ 150166 – Siphon block with measuring connection
- ▶ 270923 – Connecting unit 03 (standard)
- ▶ 270371 – Filling pump

Required tools: (according to figure above)

- ▶ Allen key, AF size 6 (①), open spanner, AF size 10 (①)
- ▶ Open spanner, AF size 17 (①)
- ▶ Filling pump with lubrication oil for filling the siphon block (①)
- ▶ Open spanner, AF size 24 (②), open spanner, AF size 32 (②)

NOTE

The safety instructions in Section 6.3.4. ⇒ Section 6.3.4 *Installing the engine wall connection and sampling funnel, and Section 2.4.1* ⇒ Section 2.4.1 *Safety instructions for potentially explosive atmospheres* apply.

- ▶ The alignment of the cutting ring must be taken into account when installing the cutting ring.
- ▶ The allowed assembly tolerance is +/- 3 degrees deviation from the horizontal alignment.
- ▶ When installing, make sure that there is sufficient clearance around the lower screw plug and the measuring connection. The two connections must be freely accessible for maintenance purposes



WARNING

Leakage from the siphon blocks can negatively affects crankcase monitoring.

- ▶ To ensure leak-tightness at the siphon block, you must observe the alignment when installing the cutting ring.
- ▶ The oil return hole of the connection screw must be closed by the tip of the filling pipe. Otherwise, the lubrication oil that is introduced will run into the crankcase and not into the ducts of the siphon block.



Description of the installation steps:

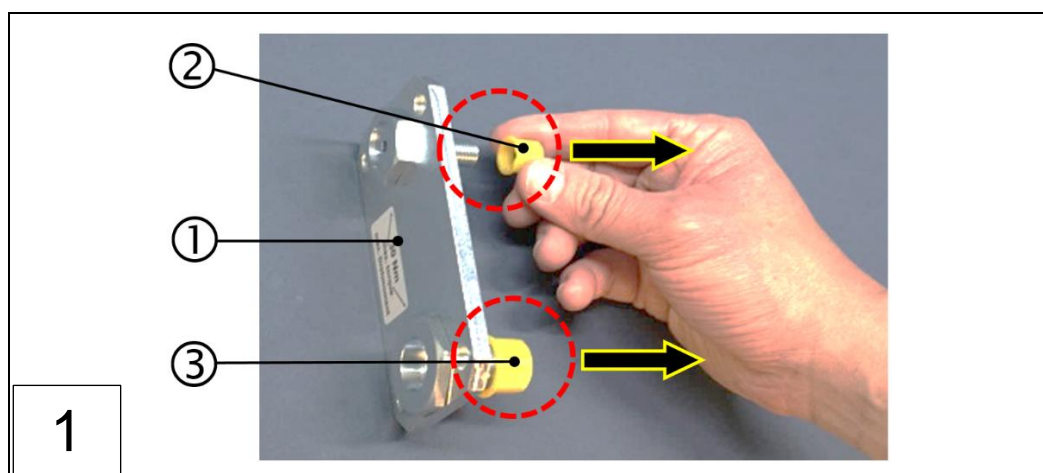

- 1: Connecting unit 03
- 3: Threaded protection cap

2: Threaded protection cap (dispose of)

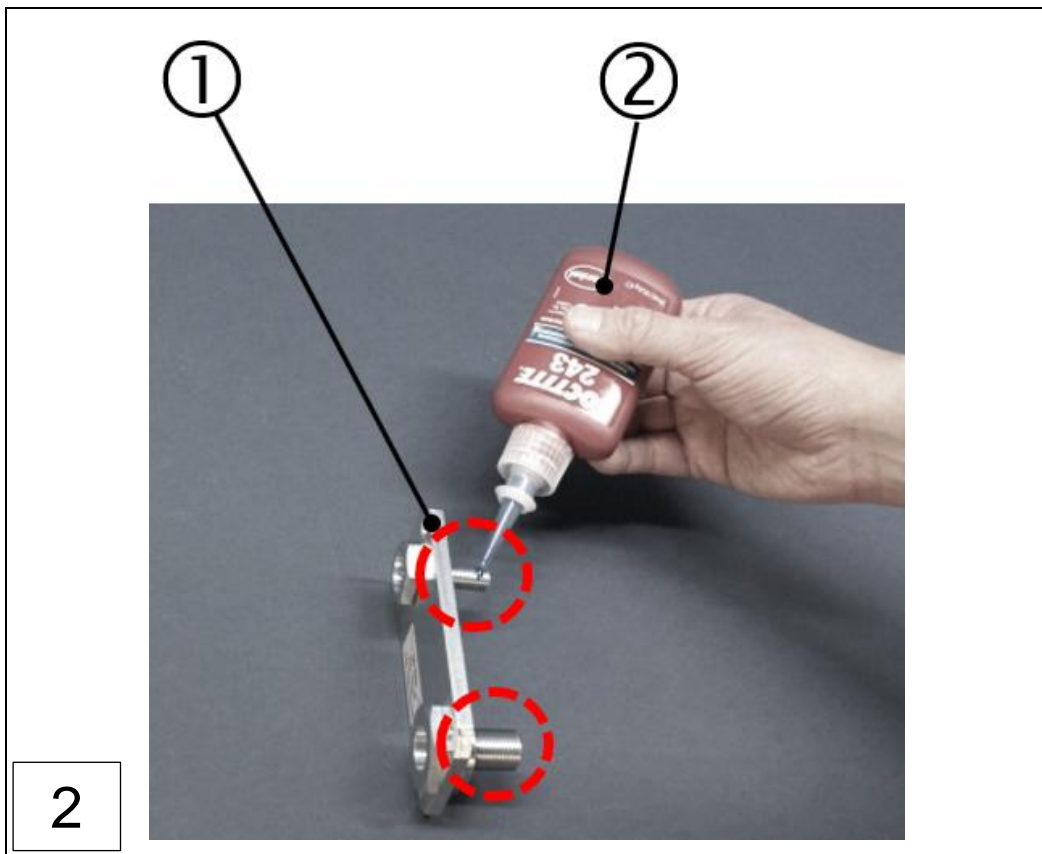

1: Connecting unit 03

2: Threadlocker (Loctite 243)

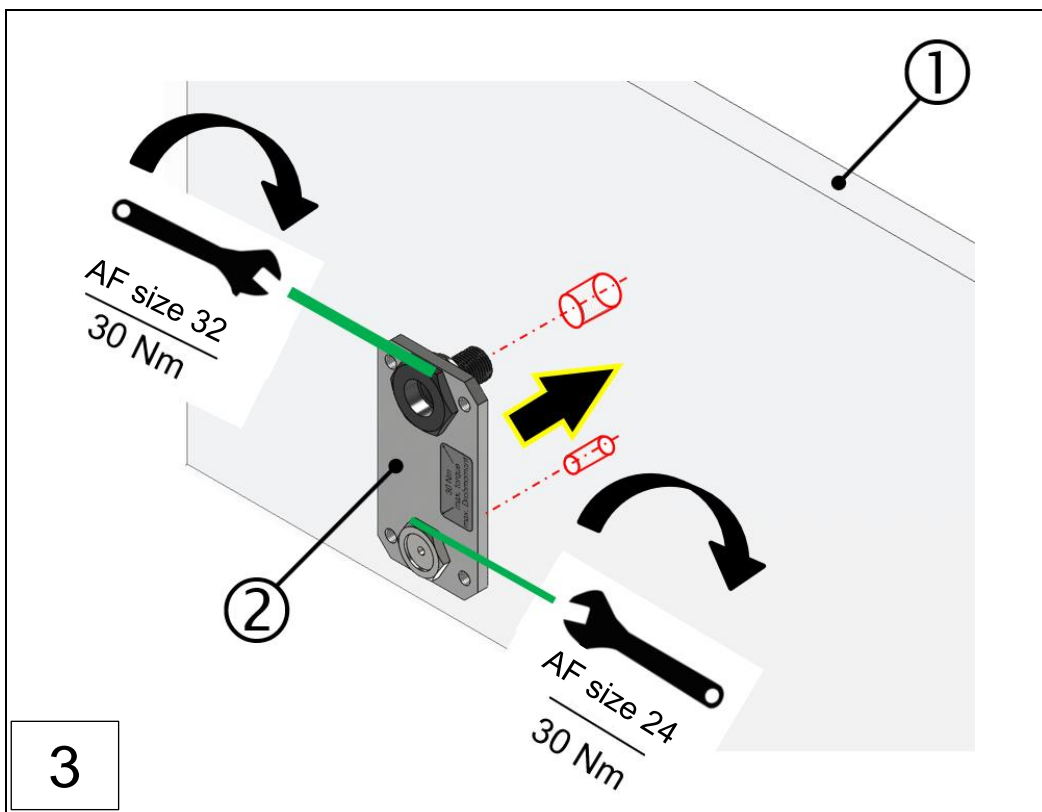

1: Engine wall

2: Connecting unit 03

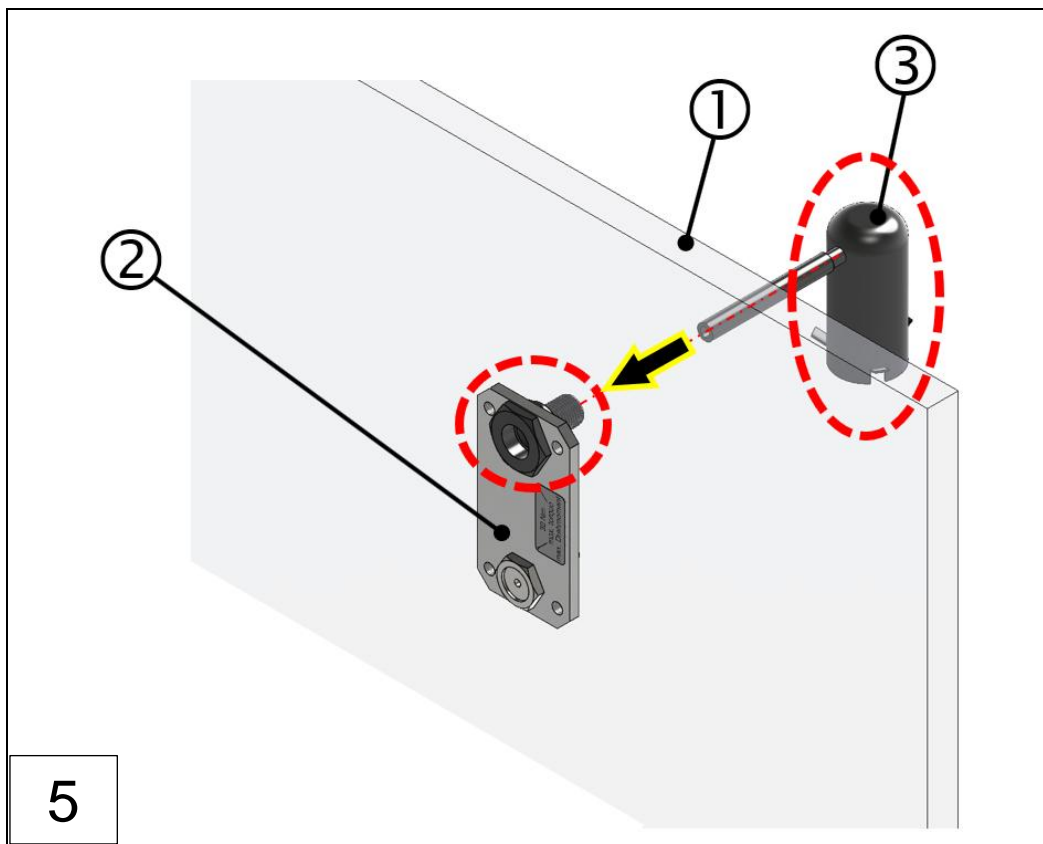
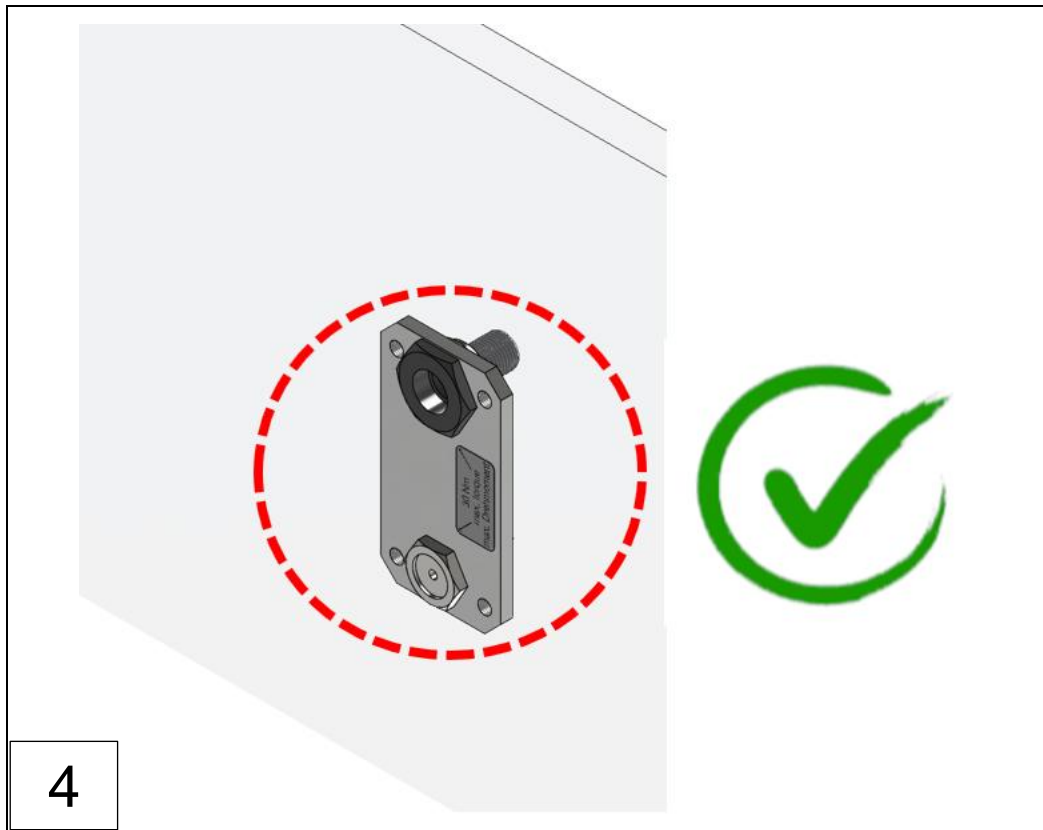

1: Engine wall
3: Sampling funnel

2: Connecting unit 03

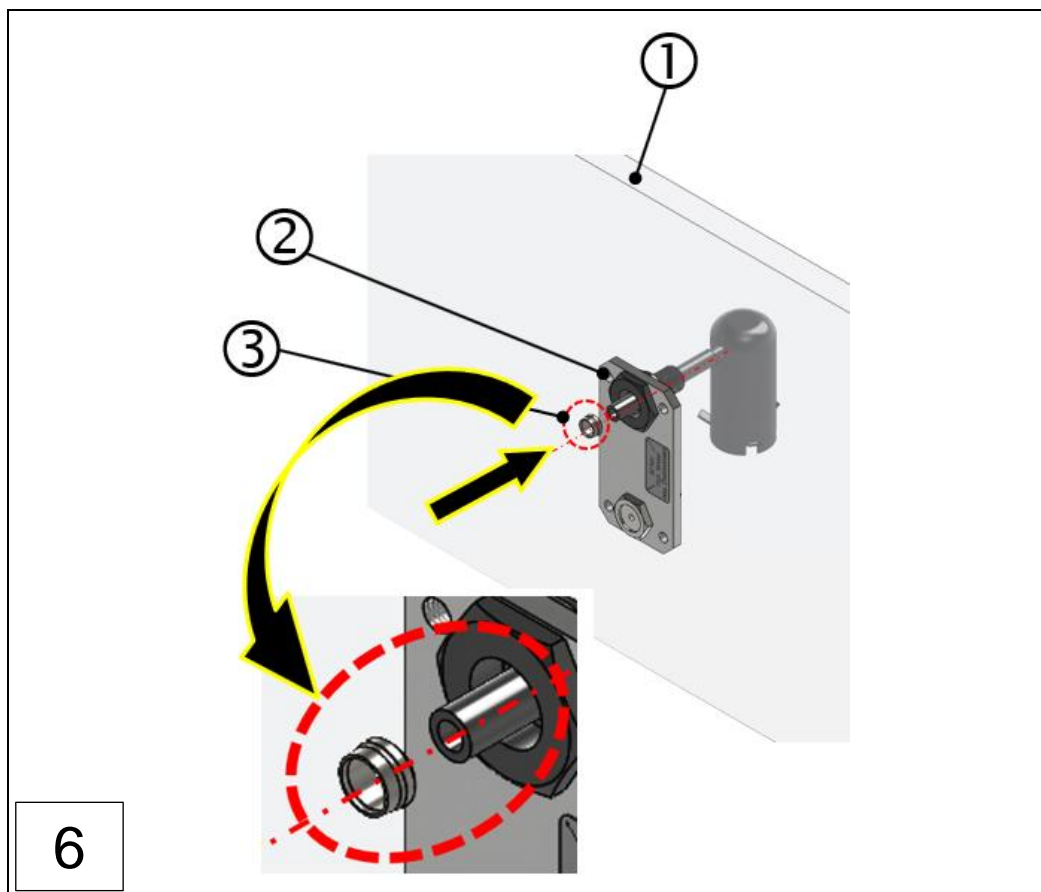

1: Engine wall
3: Cutting ring

2: Connecting unit 03

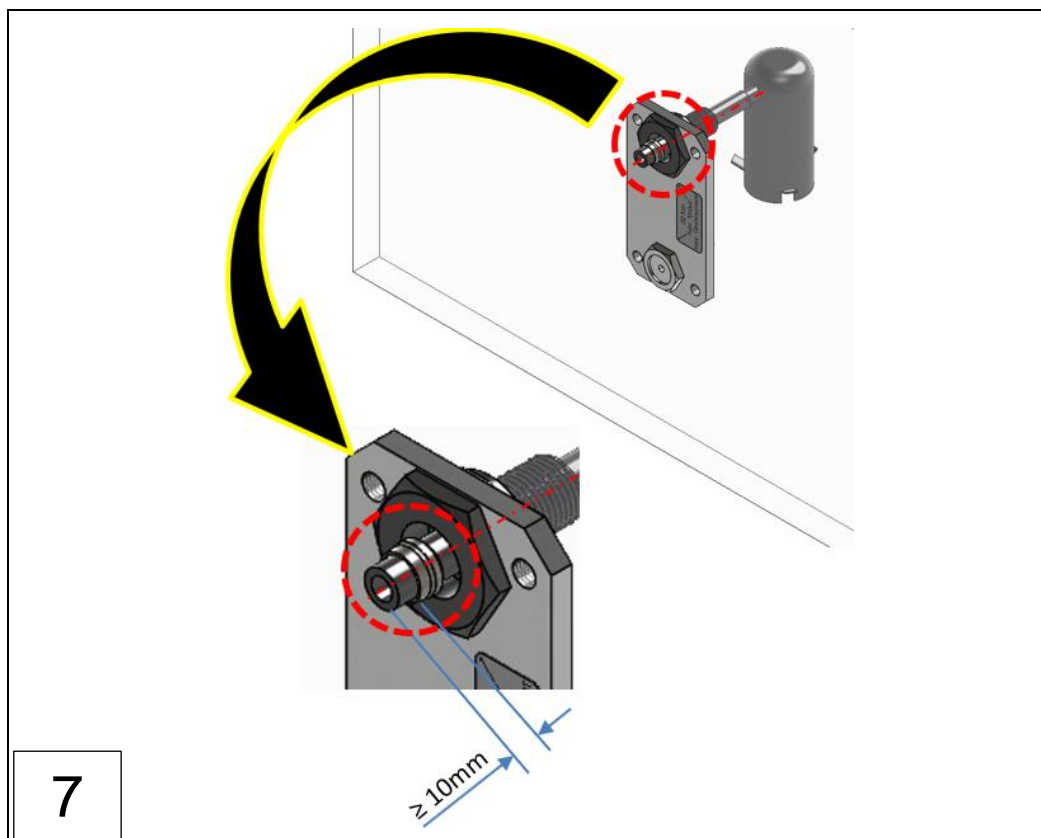

7

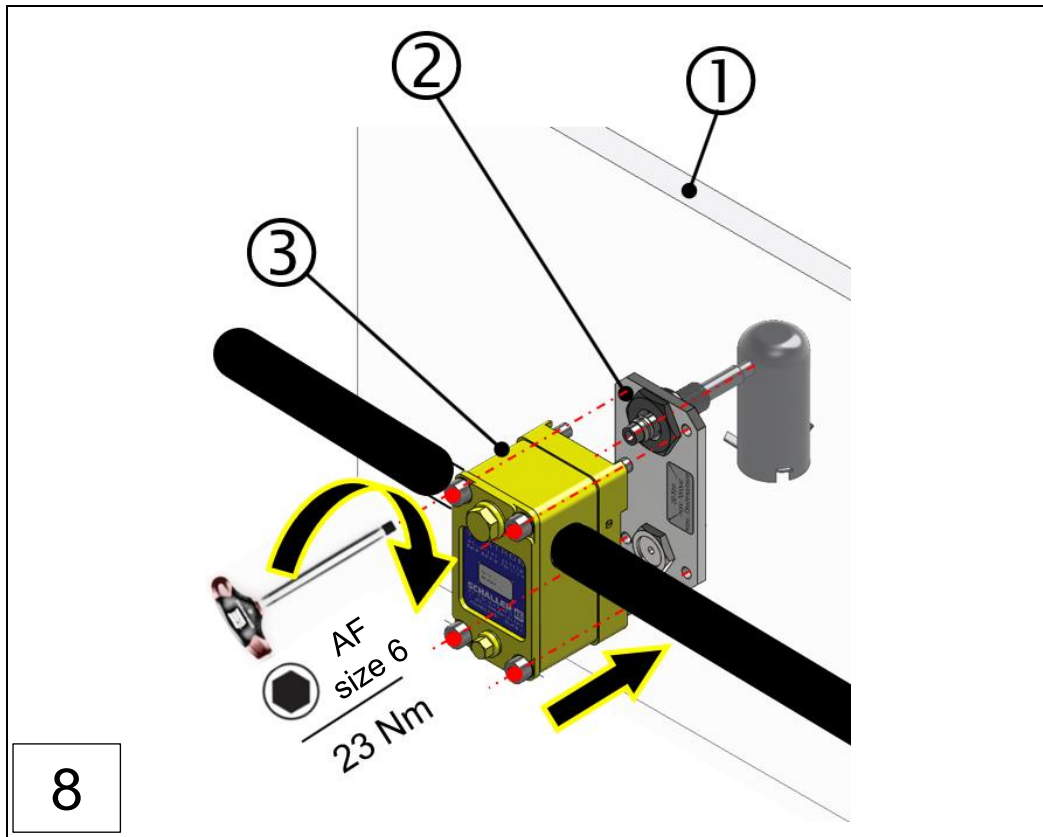

1: Engine wall
3: Siphon block

2: Connecting unit 03

NOTE: Tighten the size 6 screws crosswise!

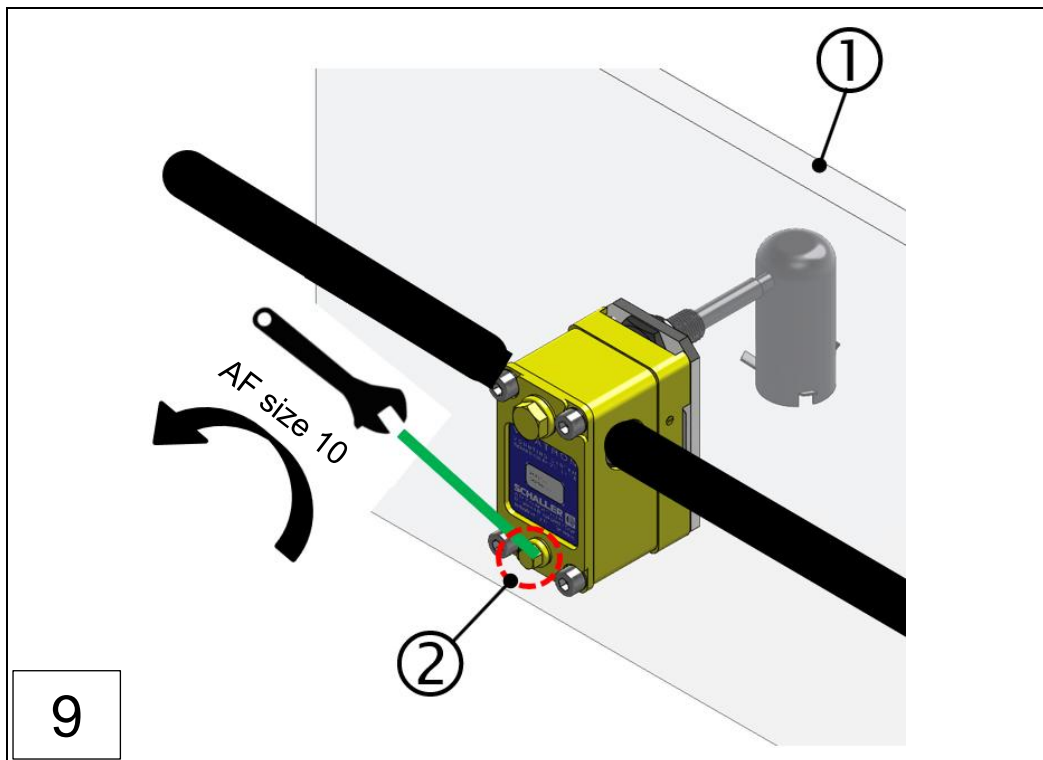

1: Engine wall

2: Screw plug DIN910 (M10x1)

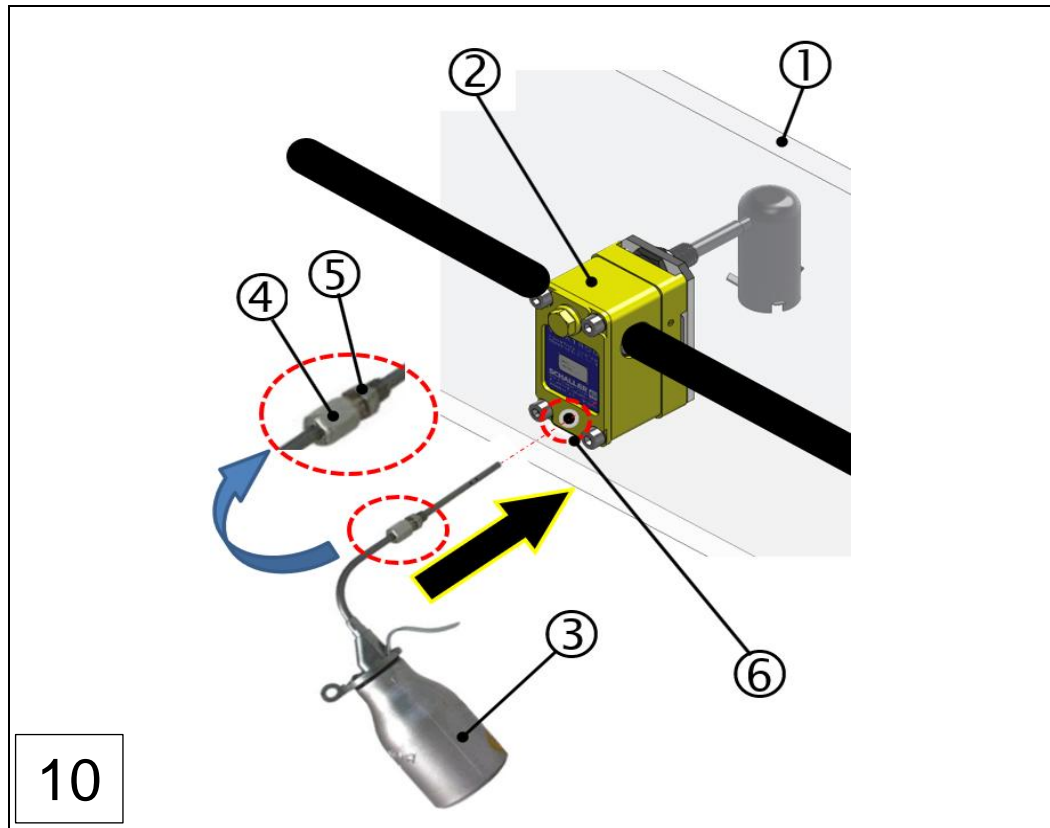

1: Engine wall
3: Filling pump
5: Screw-in nipple

2: Siphon block
4: Union nut, size 14
6: Oil return hole, siphon block

NOTE

Installing the filling pump with filling pipe on the siphon block, with subsequent operation

- ▶ Fill the filling pump with lubrication oil (lubrication oil approved by the engine manufacturer) and operate the pump mechanism until lubrication oil comes out of the side openings of the filling pipe.
- ▶ Screw the screw-in nipple (step 10, [5]) into the thread of the oil return hole (step 10, [6]) and tighten with an open spanner, AF size 10.
- ▶ Press the filling pump with filling pipe firmly against the screw-in nipple of the oil return hole and tighten the union nut (step 10, [4]) with an open spanner, AF size 14. Step 11 shows the final installation for the filling pump, mounted on the siphon block.
- ▶ Carry out a total of eight slow and even pump strokes, as described in step 11.



WARNING

- ▶ The oil return hole must be closed by the tip of the filling pipe. Otherwise, the lubrication oil that is introduced will run into the crankcase and not into the ducts of the siphon block.
- ▶ Excess oil can flow into the intake line. This impairs monitoring of a crankcase.
→ **Do not pump more than eight times!**



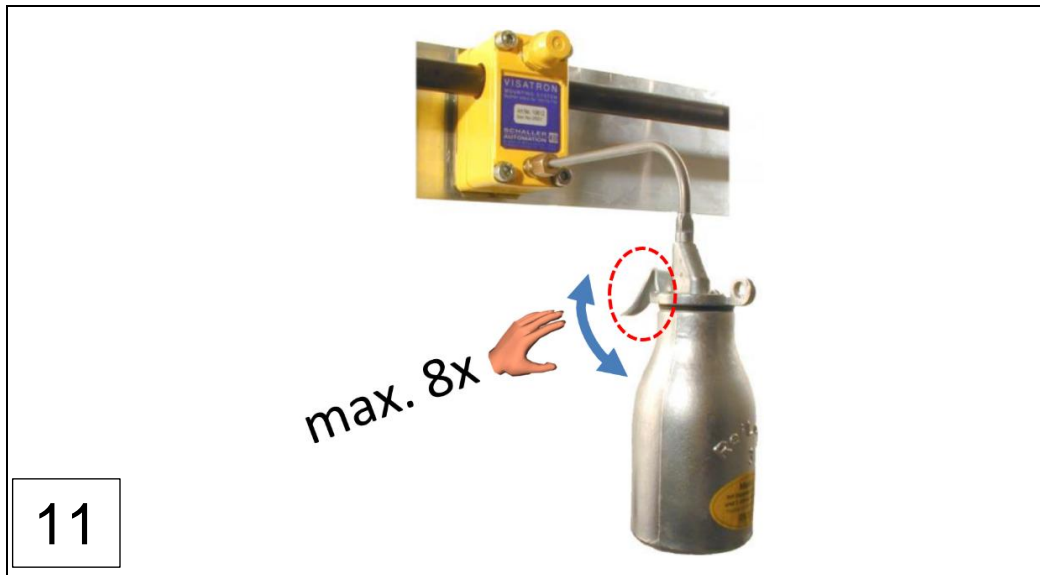

Fig.: 31 : Installing and starting up the siphon block assembly (installation steps 1-11)

NOTE

Removing the filling pump with filling pipe from the siphon block

- ▶ After filling the siphon block, remove the filling pump and screw in the screw plug (step 9, [②]) again without delay. (Open spanner, size 10)
- ▶ When the filling pump is removed, a little oil may escape from the oil return hole. However, this does not affect the function of the siphon. Then remove leaking lubrication oil with a cleaning cloth.



6.3.6 Installing the pipe siphon assembly

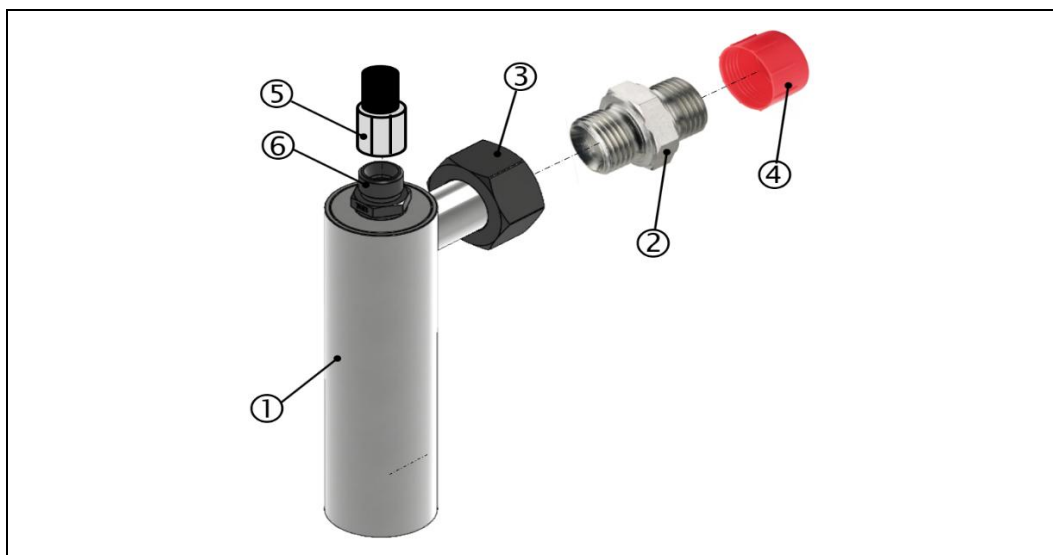

Fig.: 32 : Pipe siphon assembly

- | | |
|-------------------------------|---------------------------------|
| 1: Pipe siphon | 2: Straight screw-in socket L22 |
| 3: Union nut | 4: Protective cap |
| 5: Intake line with union L10 | 6: Straight screw-in socket L10 |

Part numbers:

- ▶ 150939 - Pipe siphon, complete

Required tools: (according to figure above)

- ▶ Open spanner, AF size 19 (⑤)
- ▶ Open spanner, AF size 32 (②)
- ▶ Open spanner, AF size 36 (③)
- ▶ Filling pump with lubrication oil for filling the pipe siphon (①)
- ▶ Torque spanner for torque up to 180 Nm (③)
- ▶ Small spirit level

NOTE

The safety instructions in Section 6.3.4. ⇒ Section 6.3.4 *Installing the engine wall connection and sampling funnel*, and Section 2.4.1 ⇒ Section 2.4.1 *Safety instructions for potentially explosive atmospheres* apply.

- ▶ The alignment of the pipe siphon must be taken into account when installing the pipe siphon.
- ▶ The allowed assembly tolerance is +/- 3 degrees deviation from the horizontal alignment.

**WARNING****Danger from component breaking**

Damage to parts or the engine

- ▶ The specified torque must be used and applies exclusively to components made of steel.



Description of the installation steps:

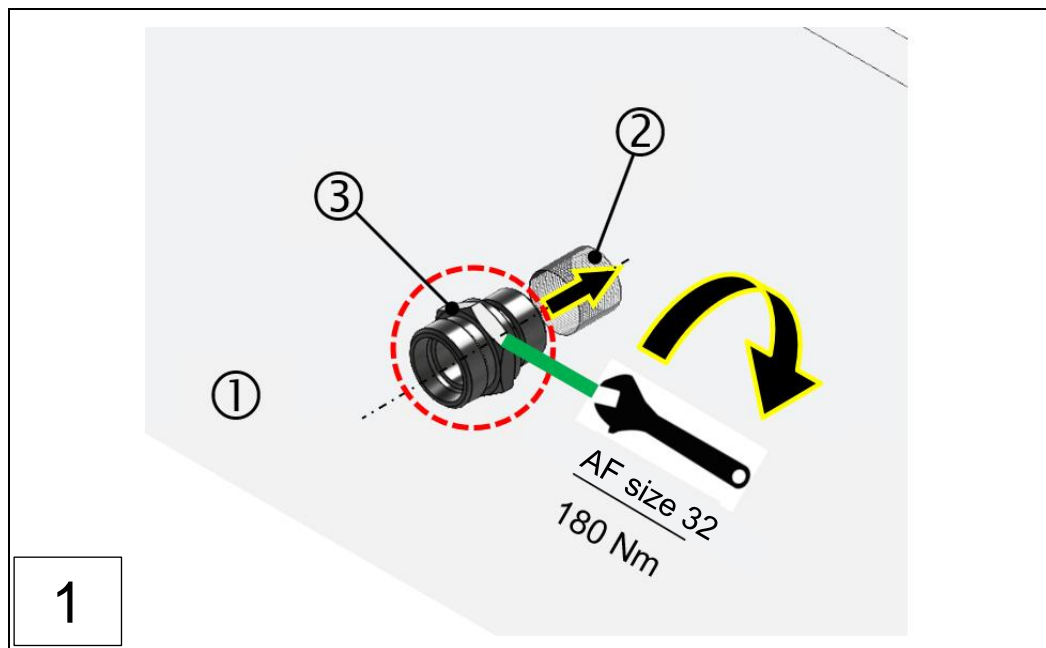

1: Engine wall

2: Screw-in thread on engine wall

3: Straight screw-in socket L22

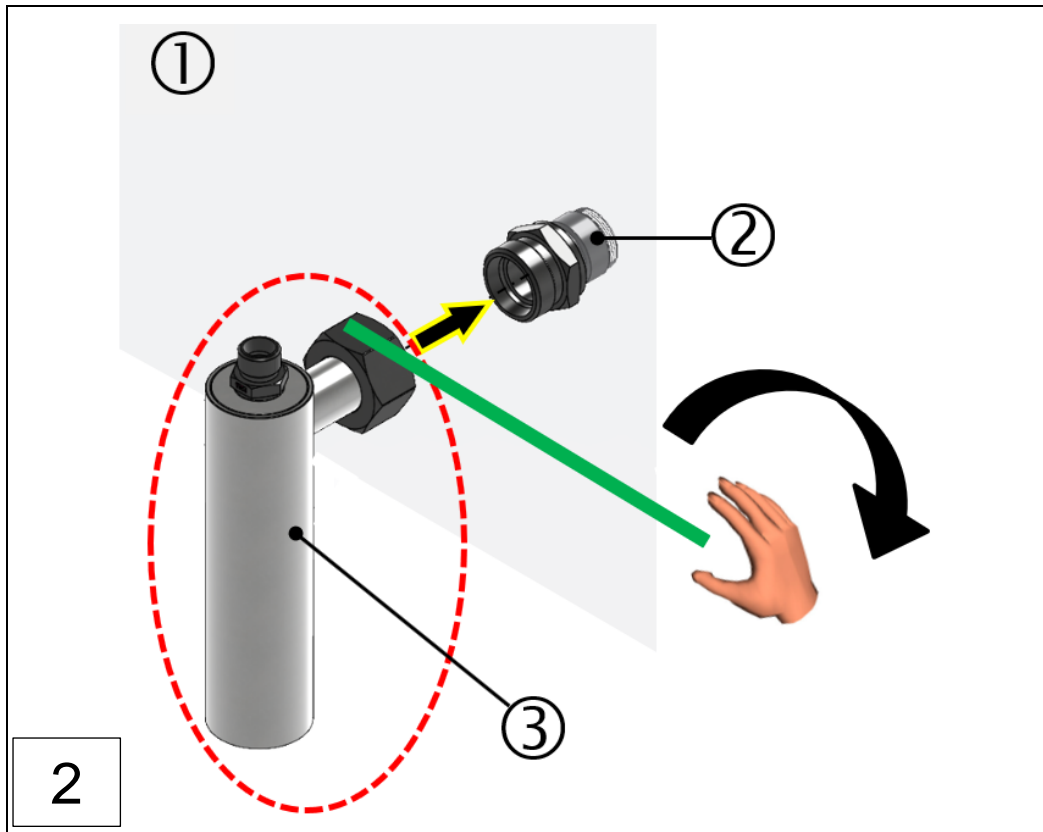

1: Engine wall
3: Pipe siphon

2: Straight screw-in socket L22

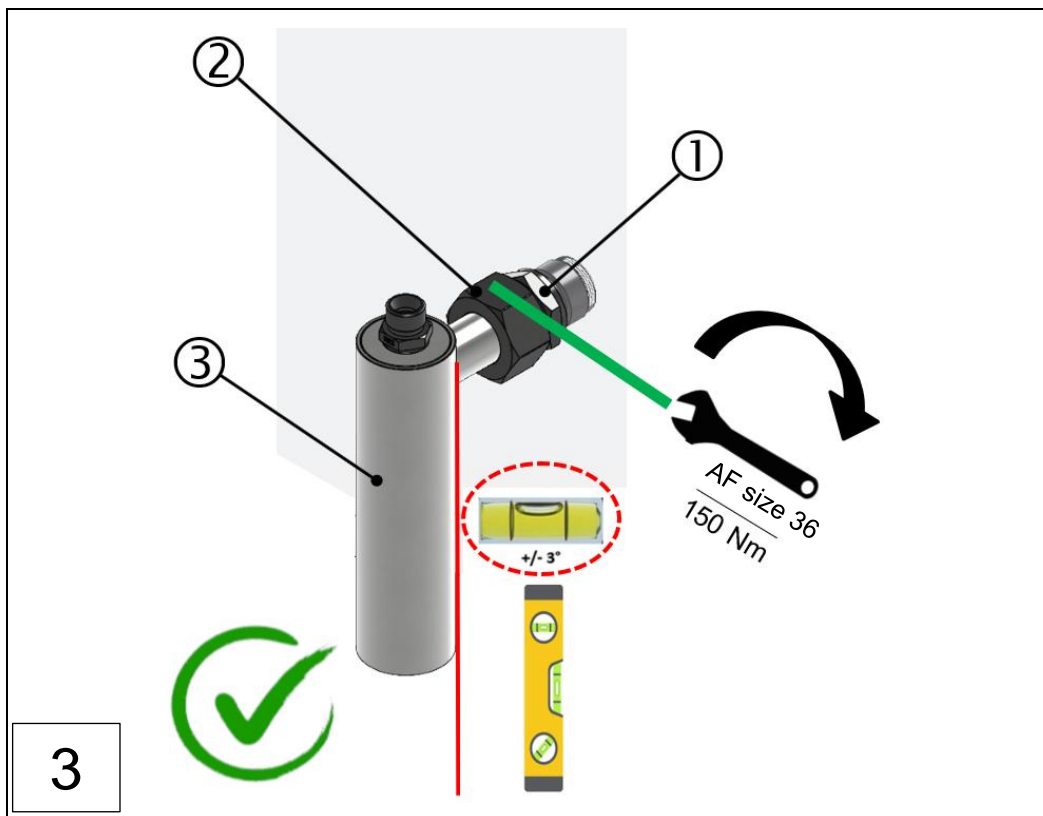

1: Straight screw-in socket L22
3: Pipe siphon

2: Union nut

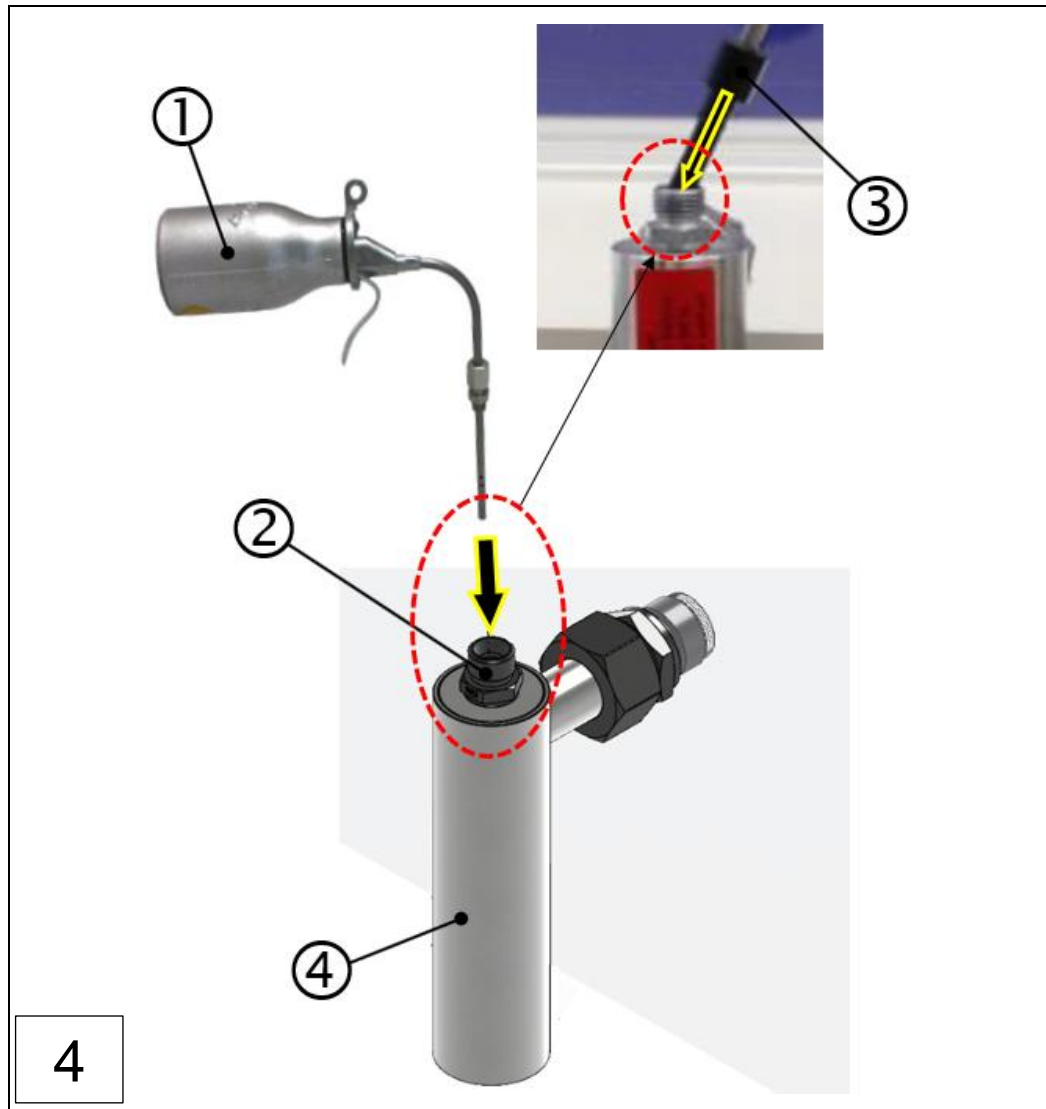

1: Filling pump
3: Filling adapter

2: Straight screw-in socket L10
4: Pipe siphon

NOTE

Installing the filling pump with filling pipe on the pipe siphon

- ▶ Start by filling the filling pump (①) with 70 ml of lubrication oil approved by the engine manufacturer/engine's own lubrication oil.
- ▶ Insert the filling adapter (③) into the straight screw-in socket L10 (②) as far as it will go.
- ▶ Fill the pipe siphon (④) via the straight screw-in socket L10 (②) with 70 ml of lubrication oil (①, lubrication oil approved by the engine manufacturer/engine's own lubrication oil).



WARNING

- ▶ The screw-in socket (②) must be completely closed by the filling adapter (③).
- ▶ Excess oil can flow into the crankcase.

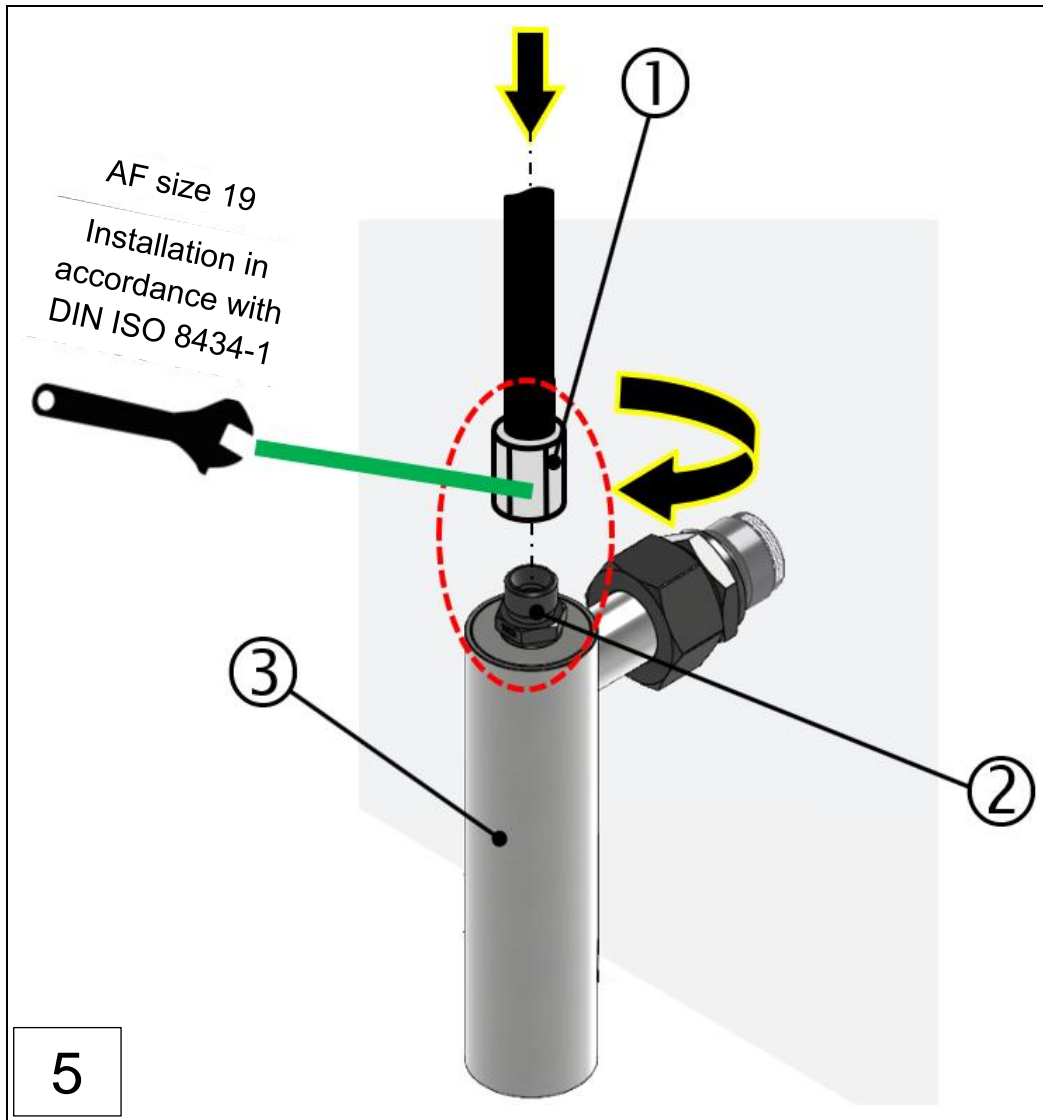

Fig.: 33 : Installing and starting up the pipe siphon assembly (installation steps 1-5)

1: Intake line with union L10
3: Pipe siphon

2: Straight screw-in socket L10

NOTE

Removing the filling pump with filling pipe from the pipe siphon and installing the intake line

- ▶ After filling the pipe siphon (③), remove the filling pump.
- ▶ Then remove leaking lubrication oil with a cleaning cloth.
- ▶ Insert the intake line flush into the screw-in socket (②) as far as it will go.
- ▶ Start by pre-assembling the L10 union hand-tight and aligning the sampling hose.
- ▶ Tighten the union L10 (①) on the straight screw-in socket (②).



6.3.7 Installing the pipes

Schaller Automation uses tried-and-tested hydraulic components for its installation kits. Only pipes (tubes) in accordance with DIN EN 10305-4 and cutting ring fittings in accordance with EN ISO 8434-1 are used.

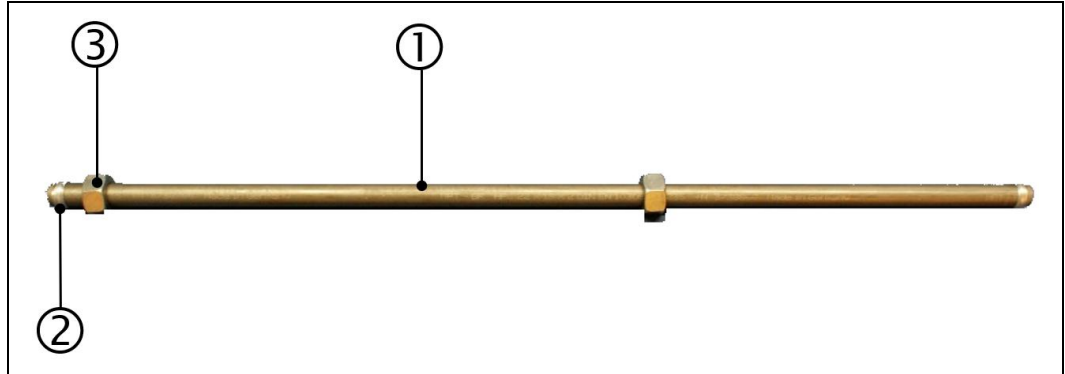

Fig.: 34 : Pipe with screw fitting, VN2020 series

1: Header pipe (straight)
3: 2x union nuts

2: 2x cutting rings

The pipes in the installation kits differ as follows:

- Pipes with pre-assembled cutting rings and union nuts
- Pipes without cutting rings and nuts
- Pipes with welded fittings including cutting rings and union nuts

Only metric pipes with external pipe diameters of

- 10 mm and
- 22 mm are used.

The pipes are attached to the pipe connectors using tried-and-tested cutting ring fittings. The applicable pipe connections are made when installing the installation kit. (See installation kit).

The total length of the suction line must not exceed **max. 9 m on left and right sides!** All installation details are provided on installation kit drawing.



WARNING

Negative impact on monitoring with the oil mist detector

- ▶ If the pipes or the installation kit is painted by the operator, a suitable paint must always be selected that will not permanently damage the pipes.
- ▶ To avoid system leaks, the cutting ring fittings must be installed or removed in accordance with the technical specifications of ISO 8434-1.
- ▶ To avoid blockages within the header pipe system, the pipes must always be installed free of U-bends and kinks. The approved installation drawing for the oil mist detector and installation kit from SCHALLER AUTOMATION **must always be followed.**

6.3.8 Installing the recirculation line

The recirculation line (②, referred to as the exhaust air pipe) as shown in the figure below is used to return the sampled crankcase atmosphere back into the crankcase. (④)



CAUTION

Safe and proper use of the device

- ▶ To use the device (①) safely and correctly, the exhaust air pipe (②) **must** be connected to the crankcase (④) at all times, thereby creating a closed circuit between the sampling and return of the crankcase atmosphere.



IMPORTANT INFORMATION

Assembling the device safely and correctly (in accordance with the figure below)

- ▶ The exhaust air pipe (②) for the return of the sampled crankcase atmosphere **must not** be longer than a total length of 4 m.
- ▶ The connection (③) for the exhaust air pipe on the crankcase must not be near a sampling point.
- ▶ In the return line (②), the 3/4-inch connection must not be reduced.
- ▶ The minimum distance is defined as an oval area with a height [H] of 300 mm and a width [W] of 200 mm around the exhaust air pipe (②).

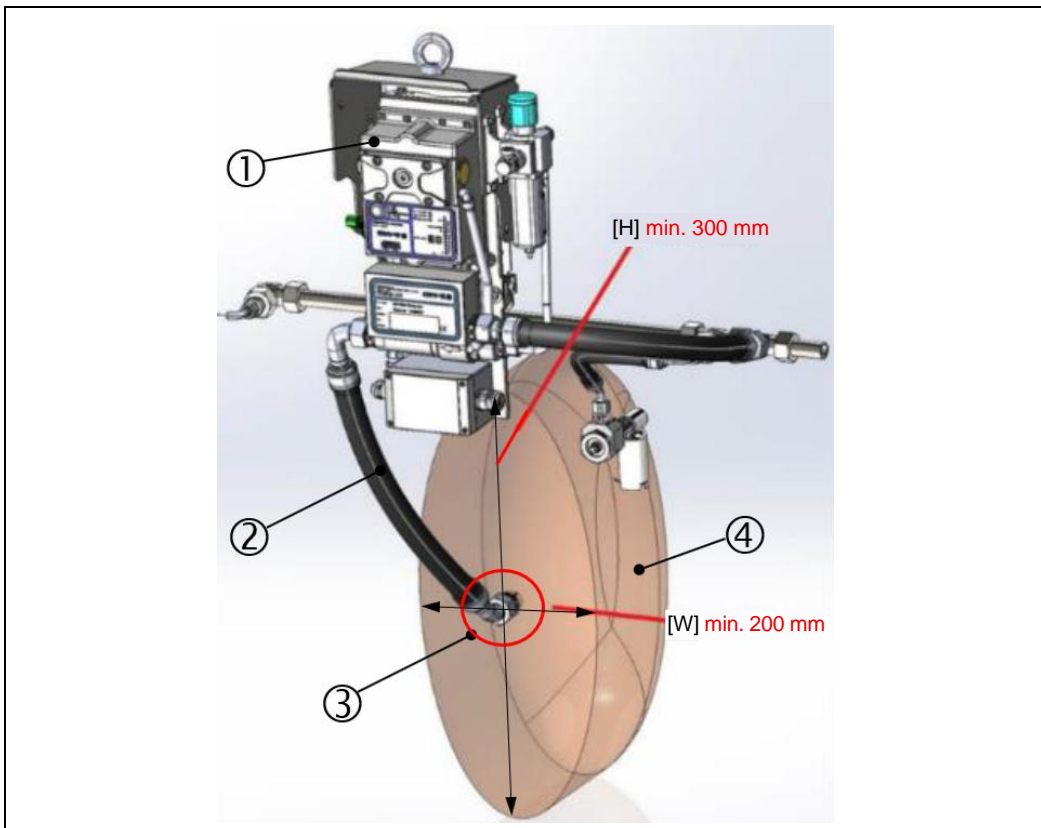

Fig.: 35 : Position of the recirculation line on the VN2020

1: VISATRON® VN2020
3: Crankcase connection

2: Exhaust air pipe/line
4: Crankcase

Required tools:

- ▶ Torque spanner for torque up to 180 Nm (step 1)
- ▶ Open-end spanner, AF size 36 (step 4)

Description of the installation steps:

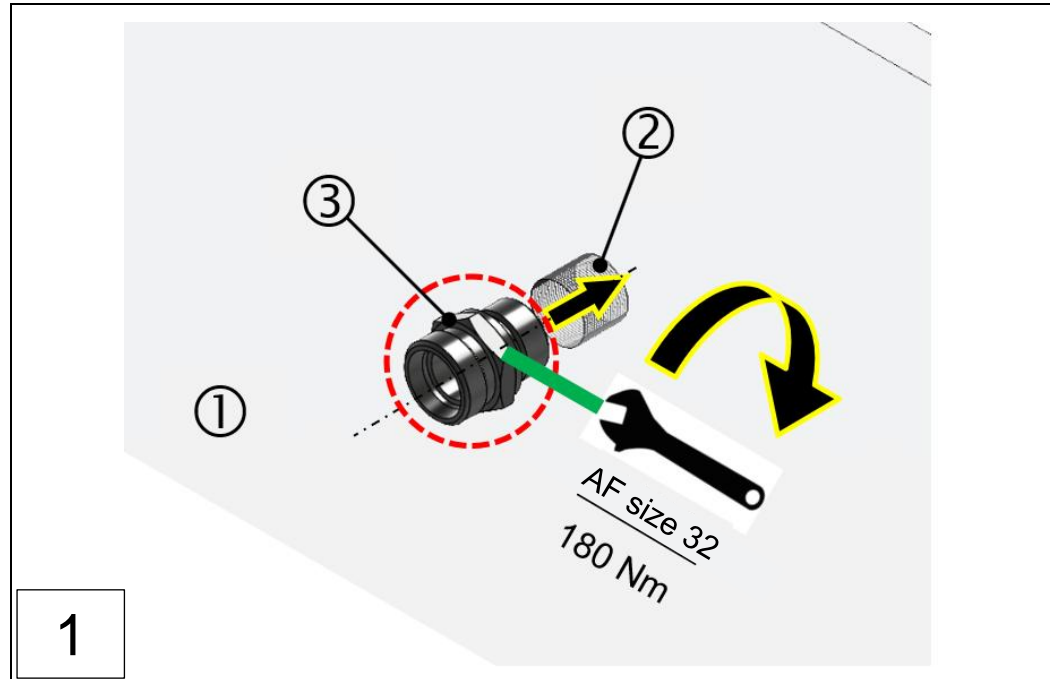

1: Engine wall
2: Screw-in thread on engine wall
3: Straight screw-in socket L22

- ▶ Torque spanner for torque up to 180 Nm (③)

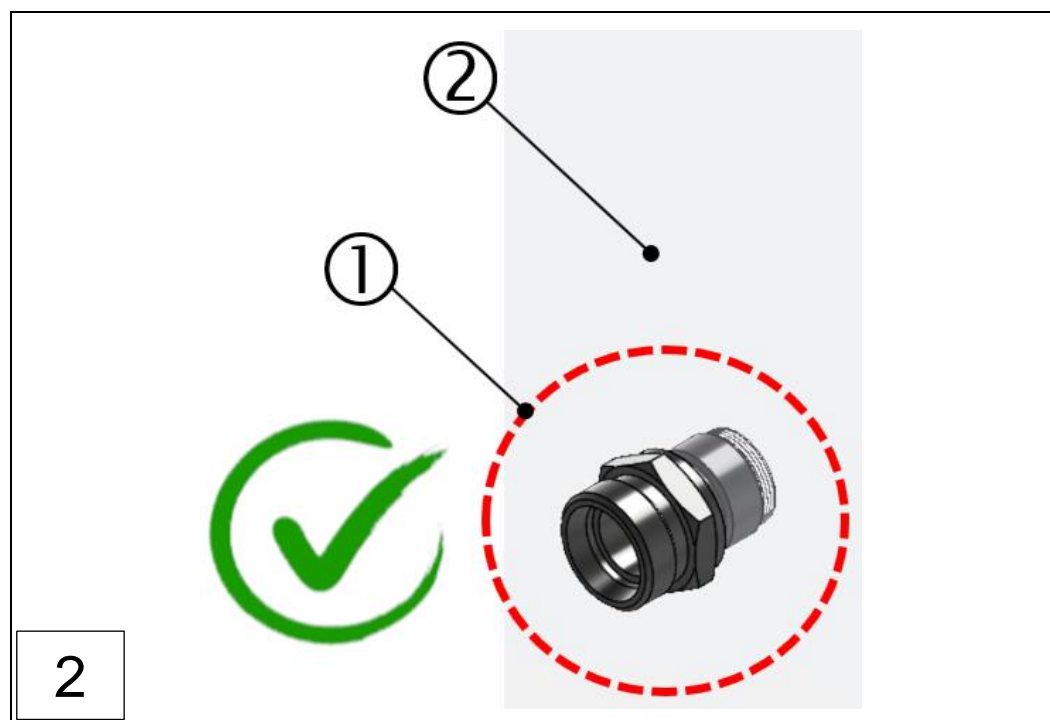

1: Straight screw-in socket L22, installed
2: Engine wall

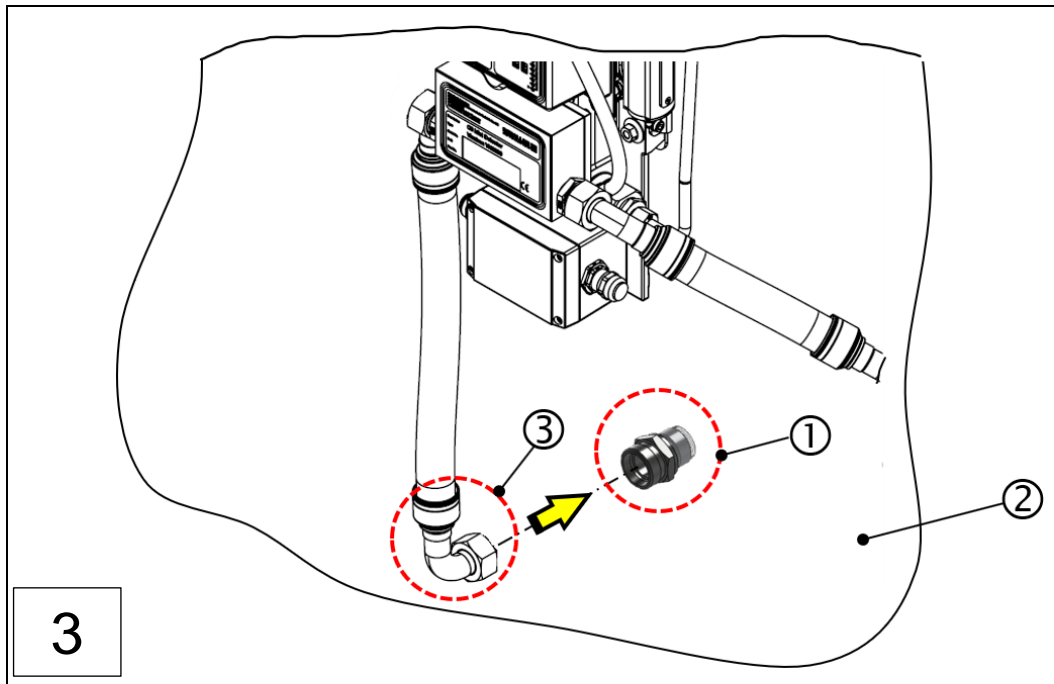

- 1: Straight screw-in socket L22, installed
- 2: Engine wall
- 3: Screw fitting for exhaust air pipe/line

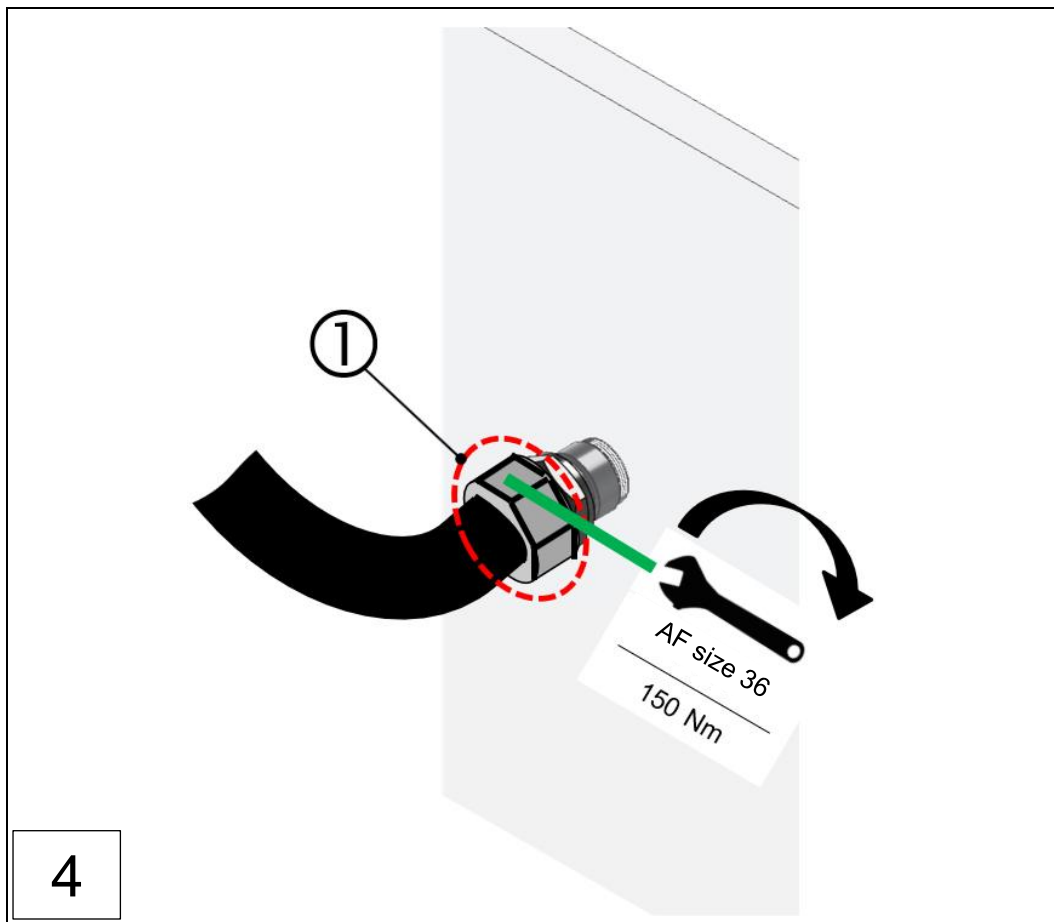

Fig.: 36 : Installing the recirculation line on the VN2020 (steps 1-4)

- 1: Screw fitting for exhaust air pipe/line

6.3.9 Installation of the hose lines

The hose lines are installed according to the installation kit drawing. The length, angle, orientation and position of the lines can vary from engine type to engine type. The instructions on the applicable installation kit drawing must be observed.

As a general rule, the pipes and hose lines should be pre-assembled in a first step, so that they can be installed free of stress as far as possible. Only after an installation kit has been completely installed should all screw connections be finally tightened to the specified tightening torque.



Fig.: 37 : Flexible hose line for the VN2020 series



WARNING

Negative impact on monitoring with the oil mist detector

- ▶ If the hose lines or the installation kit are painted by the operator, a suitable paint must always be selected that will not permanently damage the hose lines.
- ▶ To avoid system leaks, the fittings must be installed or removed in accordance with the technical specifications of ISO 8434-1.
- ▶ To avoid blockages within the header pipe system, the hose lines **must always be installed** in accordance with the approved installation drawing for the oil mist detector and installation kit from SCHALLER AUTOMATION.

6.3.10 Installing Remote Indicator II for remote monitoring (optional)

The VISATRON® VN2020/VN2020 EX can be connected to the Remote Indicator II for remote monitoring to monitor the oil mist concentration and the system status from a safe location according to IACS UR M10.

NOTE

Installing the Remote Indicator II

- ▶ The Remote Indicator II is installed in the machine control room.
- ▶ The installation space required for installation is based on the latest version of the DIN IEC 61554 standard.



Fig.: 38 : Remote Indicator II (optional)

The user provides specific details about the installation location and attachment in each case. The requirements of IACS UR M10.11 must always be observed in this case!

Dimensions for the installation space:

(L x W x 2L) = **92+0.8 mm x 45+0.6 mm x 184+0.8 mm**

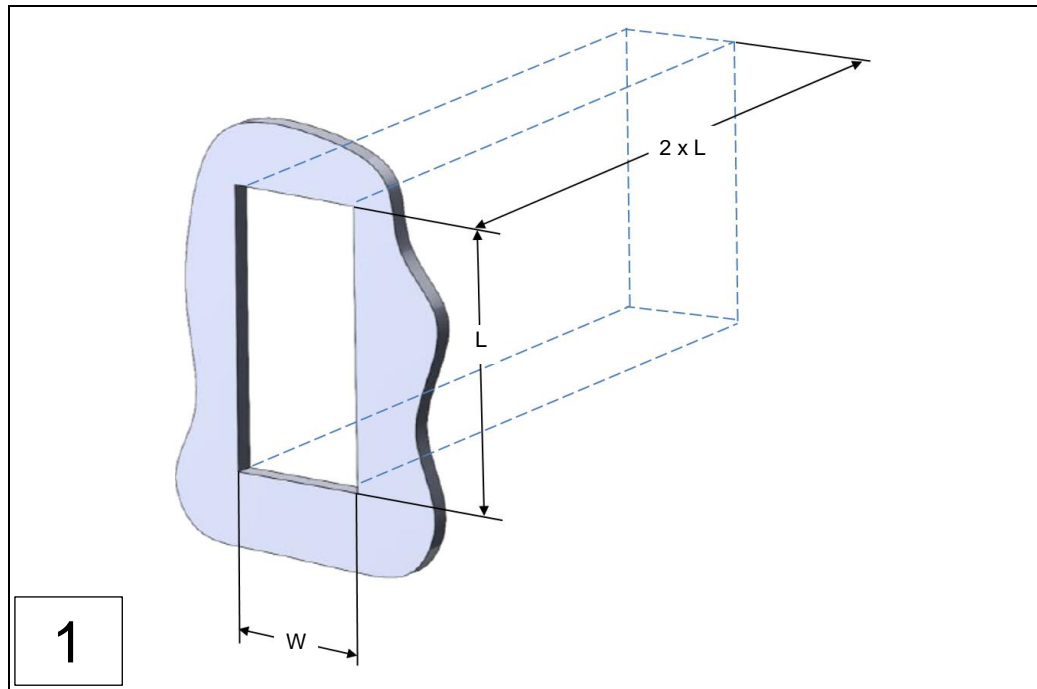
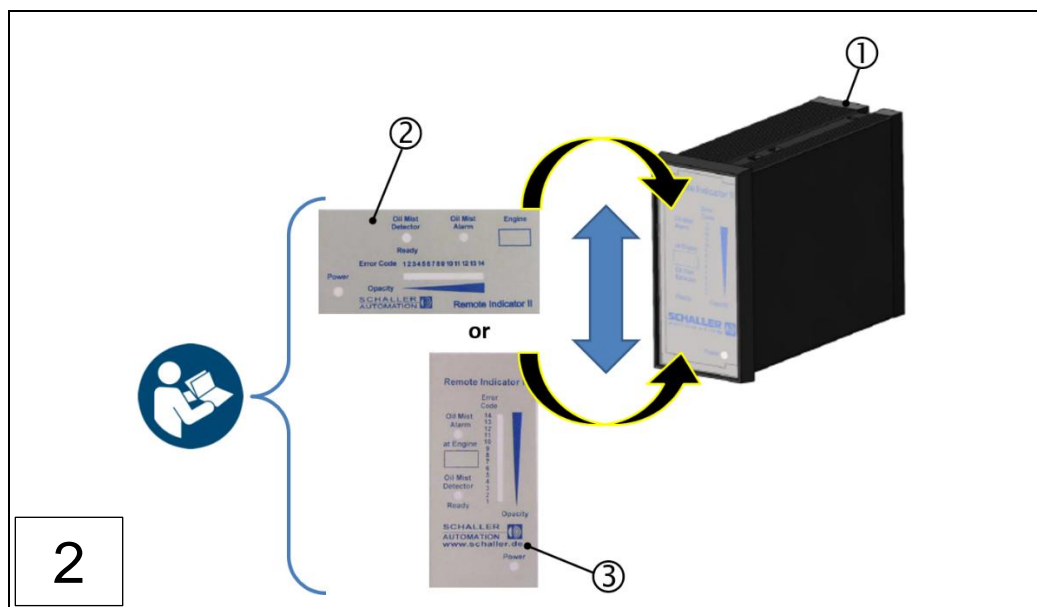

Fig.: 39 : Dimensions of installation space for Remote Indicator II

Description of the installation steps:

- Step 1: Produce the required installation space, according to the figure above.
- Step 2: Select and install the appropriate front glass panel (vertical or horizontal) in Remote Indicator II.
- Step 3: Insert Remote Indicator II into the previously prepared installation space and fit the retaining brackets.
- Step 5: Insert the fixing screws.
- Step 6: Secure Remote Indicator II with the fixing screws.



1: Remote Indicator II

2: Front glass panel for VN2020, horizontal

3: Front glass panel for VN2020, vertical

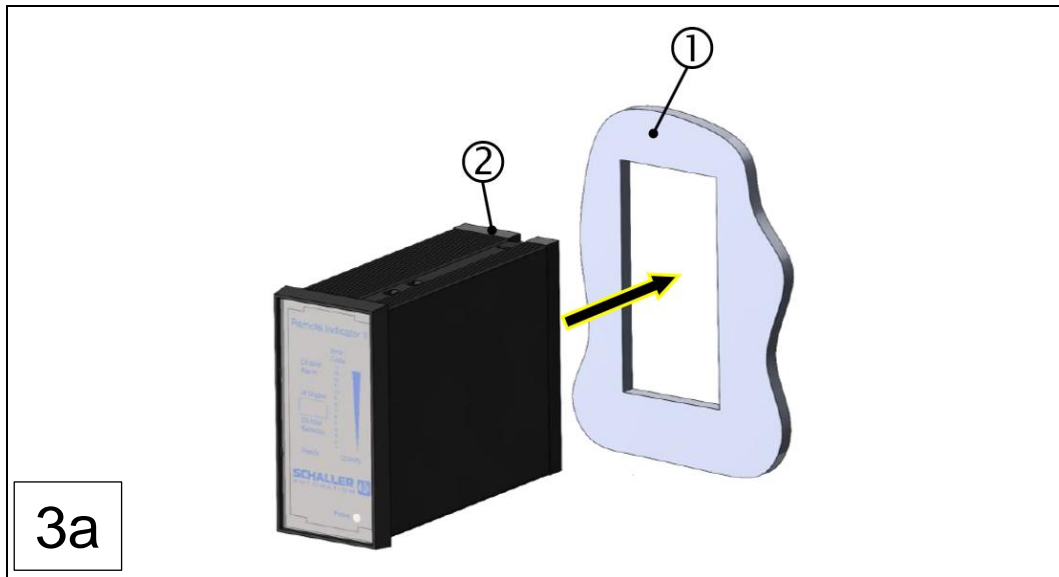

3a
1: Previously prepared installation space 2: Remote Indicator II

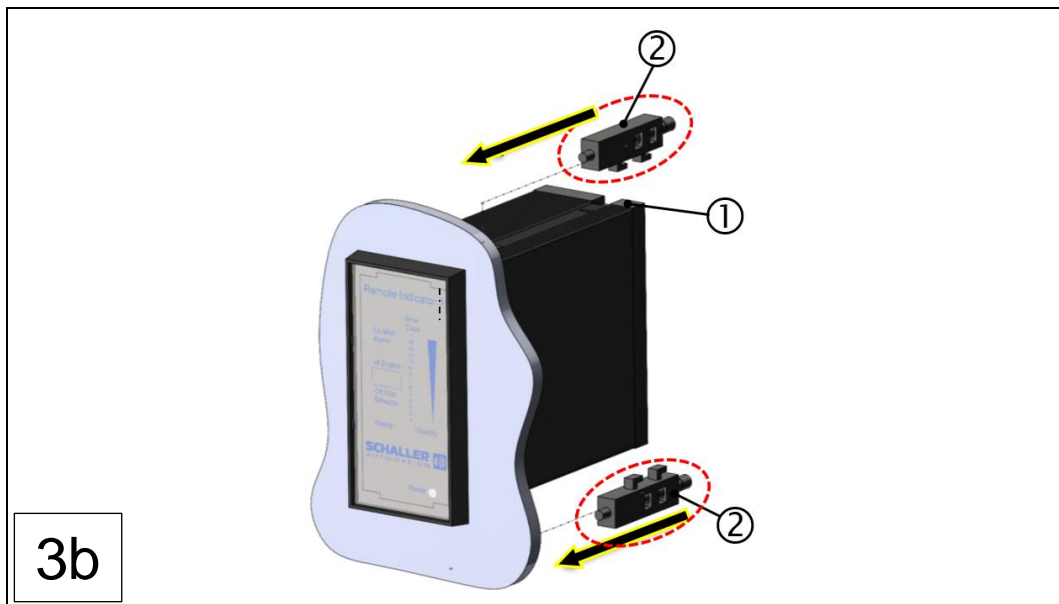



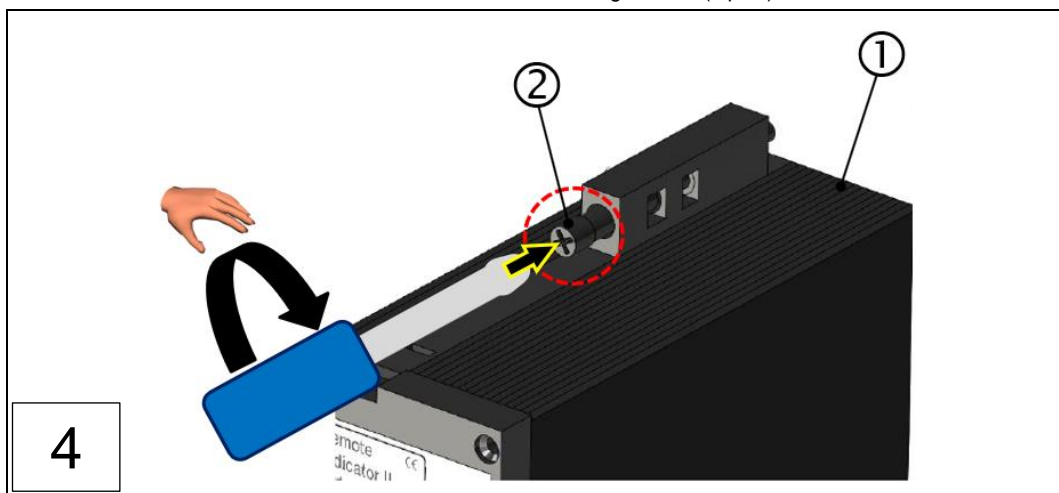









3b
1: Remote Indicator II 2: Retaining bracket (2 pcs.)



4
Fig.: 40 : Installing Remote Indicator II (installation steps 1-4)
1: Remote Indicator II 2: Fixing screws (2 pcs.)

6.4 Electrical installation

	<div style="background-color: #FFD700; padding: 5px;">⚠ CAUTION</div> <p>Safe and correct electrical installation of the device</p> <ul style="list-style-type: none"> ▶ For electrical installation of the system components, read the operating manual and other documents accompanying the product with care and keep them in a suitable place for future reference. 
 	<div style="background-color: #0056b3; color: white; padding: 5px;">NOTE</div> <p>Personal protective equipment</p> <p>Operating the device or working on the device <u>without</u> protective equipment may result in serious injury. For the workplace PPE, the following protective equipment must be used:</p> <ul style="list-style-type: none"> ▶ DIN EN 388:2016 Protective gloves against mechanical risks, 2341X, and DIN EN 407:2004 Protective gloves against thermal risks, X1XXXX ▶ Safety glasses in accordance with DIN EN 166 or DIN EN 170 ▶ Safety helmet in accordance with DIN EN 397 or DIN EN 50365 ▶ ESD safety shoes according to ESD standard DIN EN 61340-5-1.
  	<div style="background-color: #800000; color: white; padding: 5px;">⚠ DANGER</div> <p>Mechanical hazards</p> <p>There is a risk of serious injury, including death, from explosion in the crankcase as a result of incorrect assembly or installation.</p> <ul style="list-style-type: none"> ▶ Before the engine is started, all screw connections on the header pipe, engine wall connection and pipe siphons must be connected to the oil mist detector <u>and</u> properly tightened. Failure to do this means that an explosive atmosphere may escape from the engine and lead to a risk of explosion. ▶ If the oil mist detector is operated in explosion-proof areas, the relevant safety instructions must be observed. → Section 2.4.1 Safety instructions for potentially explosive atmospheres
 	<div style="background-color: #800000; color: white; padding: 5px;">⚠ DANGER</div> <p>Hazards during electrical installation</p> <p>There is a risk of serious injury, including death, due to explosion in the crankcase as a result of incorrect installation.</p> <ul style="list-style-type: none"> ▶ You may only carry out electrical installation of the oil mist detector when the engine is switched off and the system has been disconnected from the power supply first! The compressed air supply to the oil mist detector must also be switched off first. ▶ Before starting assembly, the housing of the VISATRON® VN2020/VN2020 EX oil mist detector must be earthed.   



WARNING

Failure to comply with the safety instructions may result in major damage to property or the environment and in serious injury or death.

- ▶ Familiarise yourself with the basic safety instructions before starting electrical installation. → Section 2.4 Basic safety instructions

6.4.1 Connection options for the oil mist detector (overview)

The oil mist detector is connected to the operator network and the safety interfaces via the connecting lines as follows. The figure below shows a schematic of the connection between the oil mist detector and the operator, and also describes the connection options for transferring signals to external display devices.

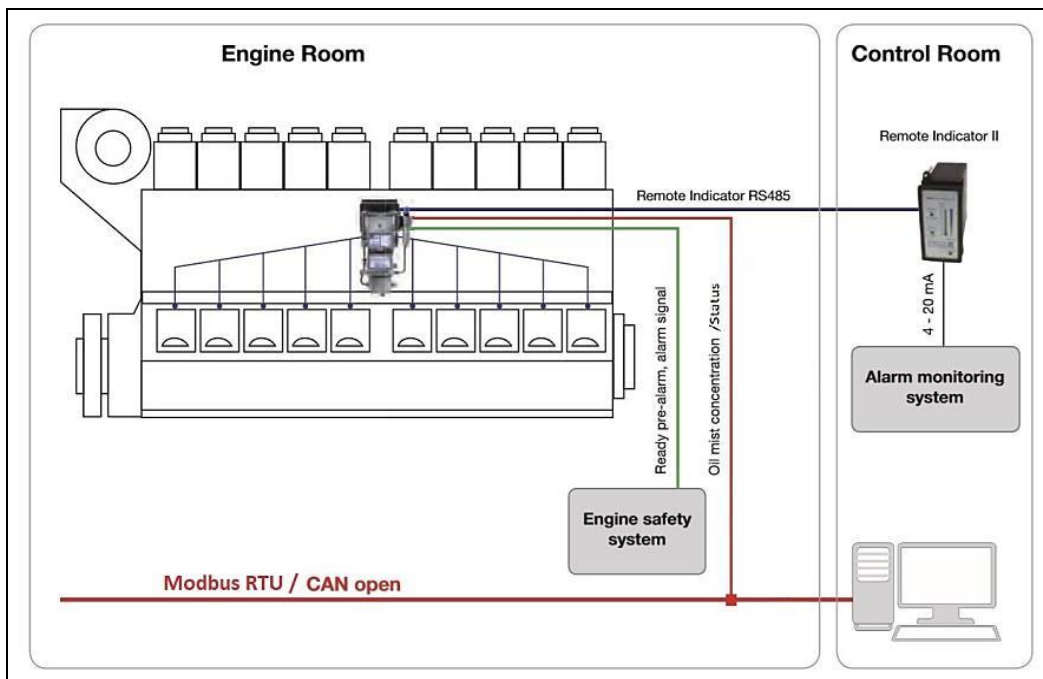

Fig.: 41 : Connection diagram for VN2020

The electrical connection of the oil mist detector is via the terminal box on the bottom side of the base plate. The wire break resistors installed on delivery can be adapted and replaced to customer-specific requirements.

6.4.2 Electrical installation of the terminal box for the VN2020 series

All the electrical terminal connections are on the connection board of the terminal box, to which the bus and alarm supply lines and the power supply are connected, as shown in the figure below.

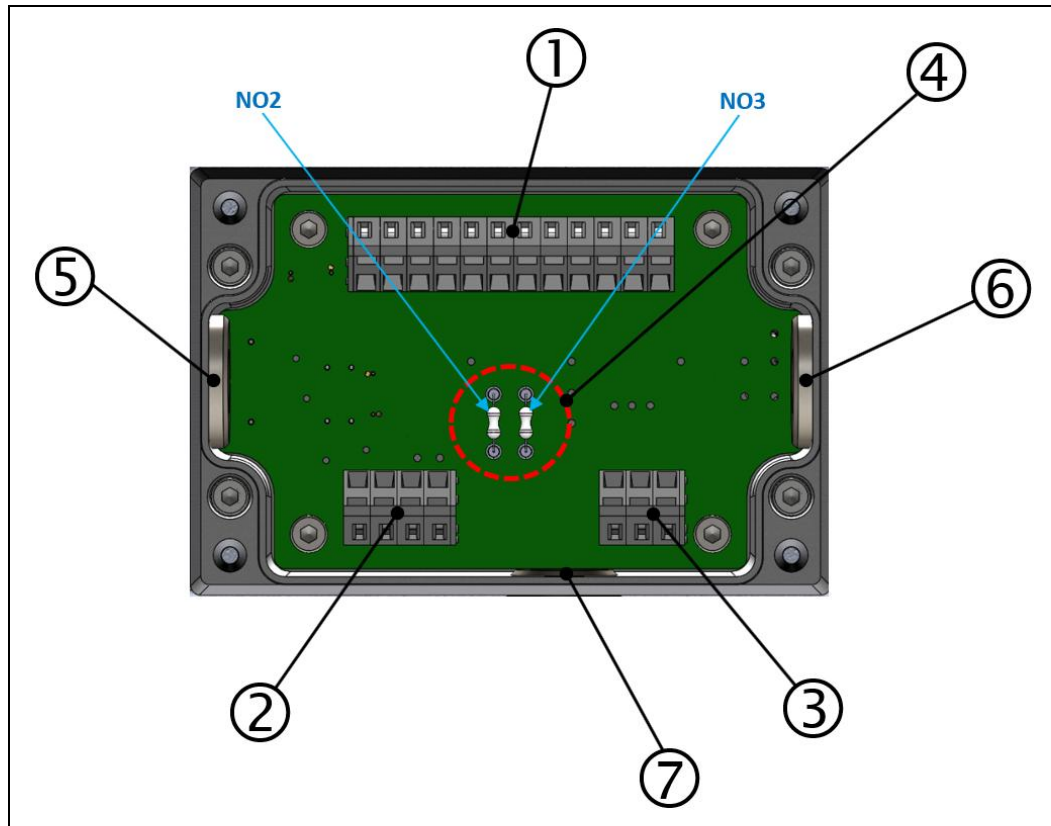

Fig.: 42 : Connection board, VN2020 terminal box

- | | | |
|--------------------------------------|--------------------------------------|------------------------|
| 1: "Relay" terminal strip | 3: "Remote indicator" terminal strip | 5: Cable entry, left |
| 2: "Power supply 24V" terminal strip | 4: Wire break resistors, NO2/NO3 | 6: Cable entry, right |
| | | 7: Cable entry, bottom |

Required tools:

- ▶ Cross-head screwdriver, drive PH 2
- ▶ Slotted screwdriver, width 2.5 mm

The electrical installation of the terminal box is completed in a total of 6 steps:

Step 1: Remove cover of terminal box.

Step 2: Select and install the wire break resistors according to the terminal box circuit diagram.

Step 3: Electrical connection of the relay contacts.

Step 4: Electrical connection of the remote indicator. (optional)

Step 5: Electrical connection of the power supply.

Step 6: Electrical connection of the housing earthing.

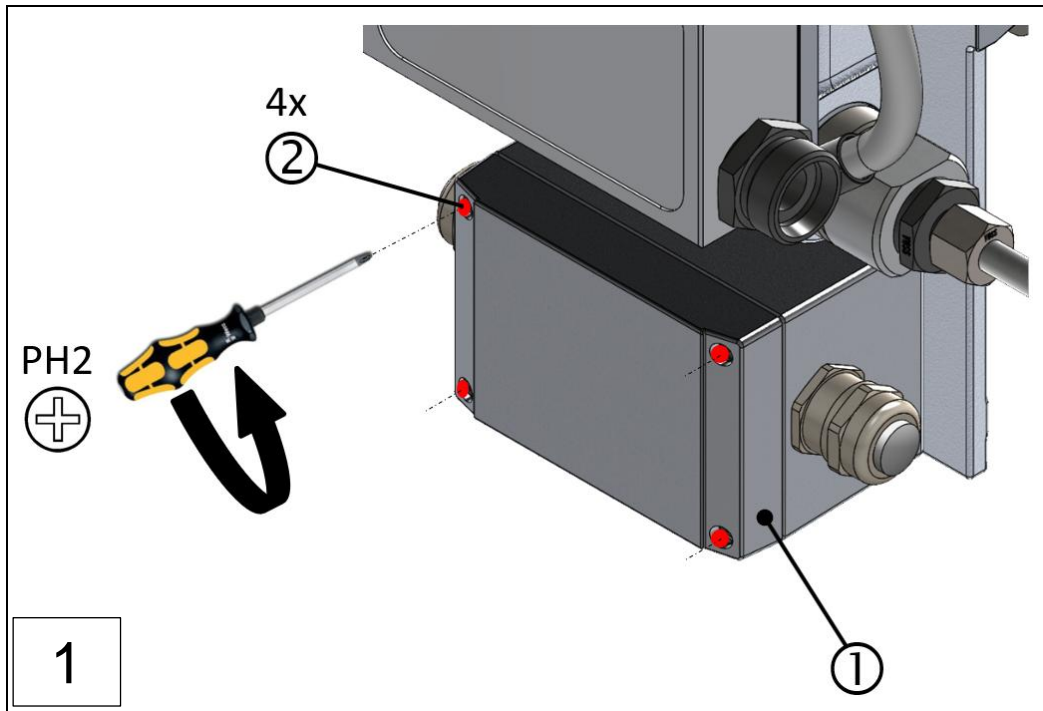

1: Cover, VN2020 terminal box

2: Fixing screws

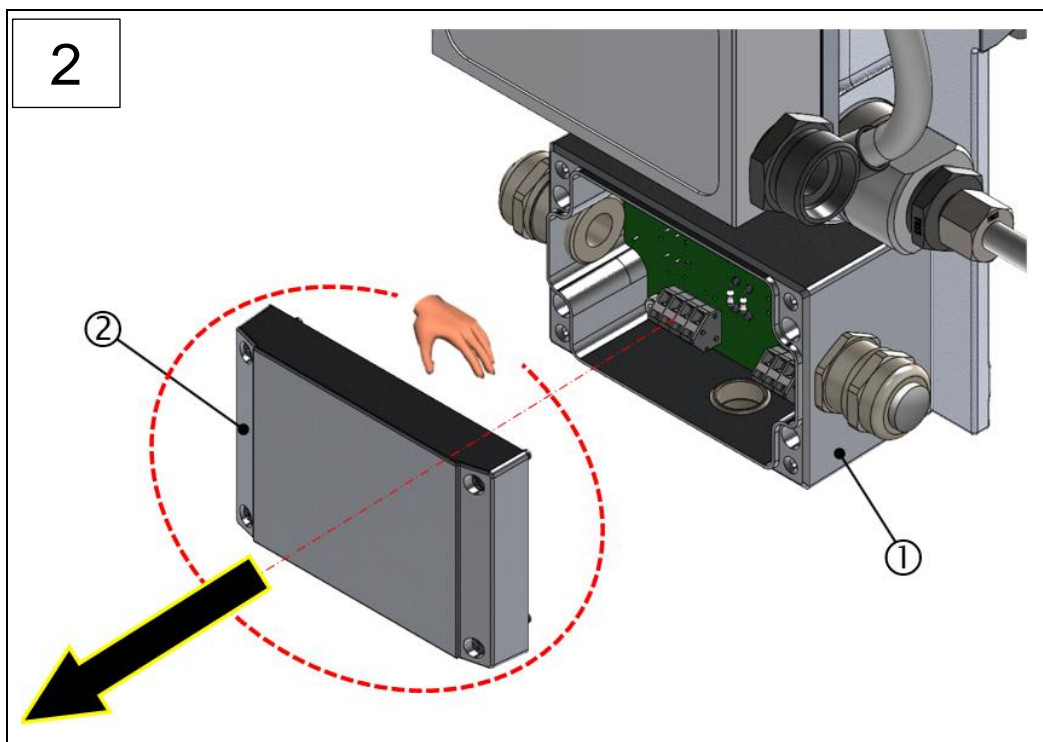

Fig.: 43 : VN2020 terminal box: Removing the cover (installation steps 1-2)

1: VN2020 terminal box

2: Cover, VN2020 terminal box

6.4.2.1 Configuration of the wire break resistors on the VN2020 terminal box

As shown in the figure below, the standard configuration of the wire break resistors as delivered is 33 kΩ. The wire break resistors can be adapted to customer-specific requirements or swapped out. A set of suitable resistors is included in the delivery.

NOTE



Swapping out wire break resistors

- ▶ The wire break resistors are only plugged in and permanently secured by the springs inside. No soldering is necessary for the resistors!

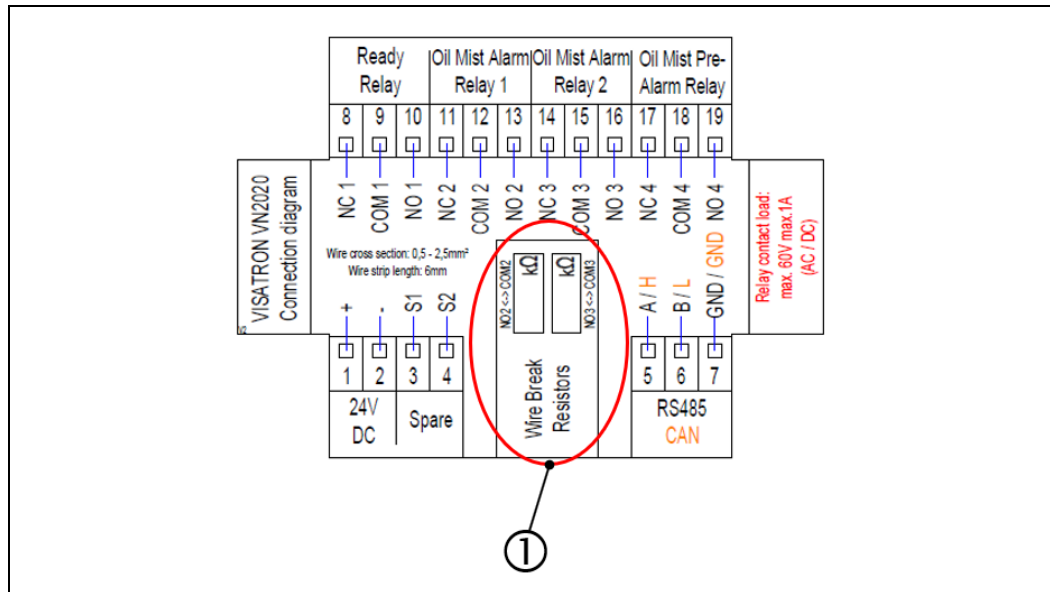
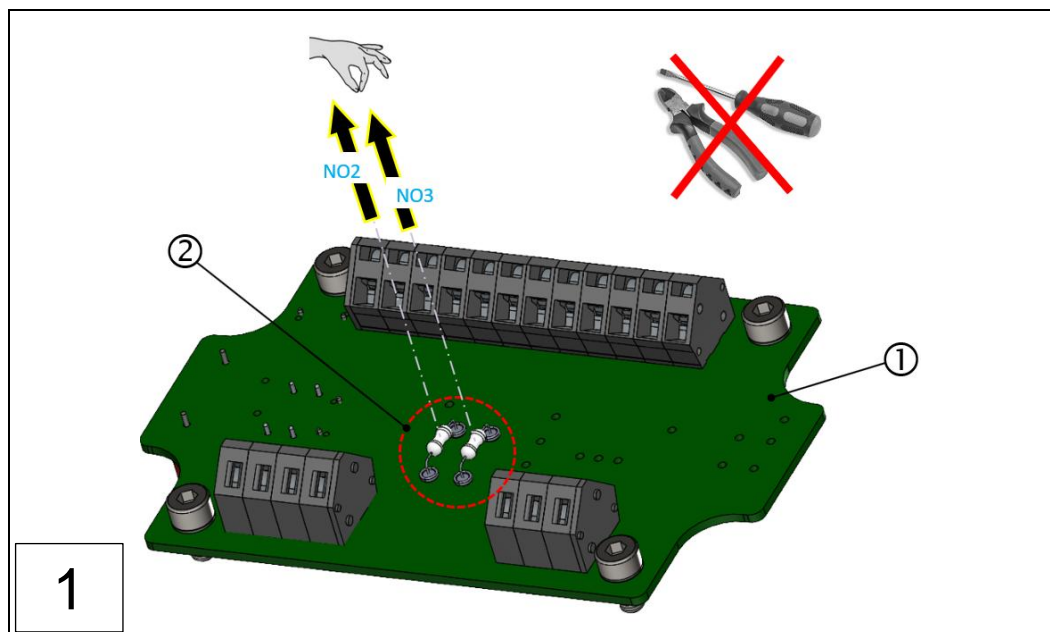

Fig.: 44 : VN2020 terminal box: Configuration of the wire break resistors

- 1: Position of wire break resistors
NO2 and NO3



- 1: Connection board, VN2020 terminal box 2: Wire break resistors, VN2020 terminal box

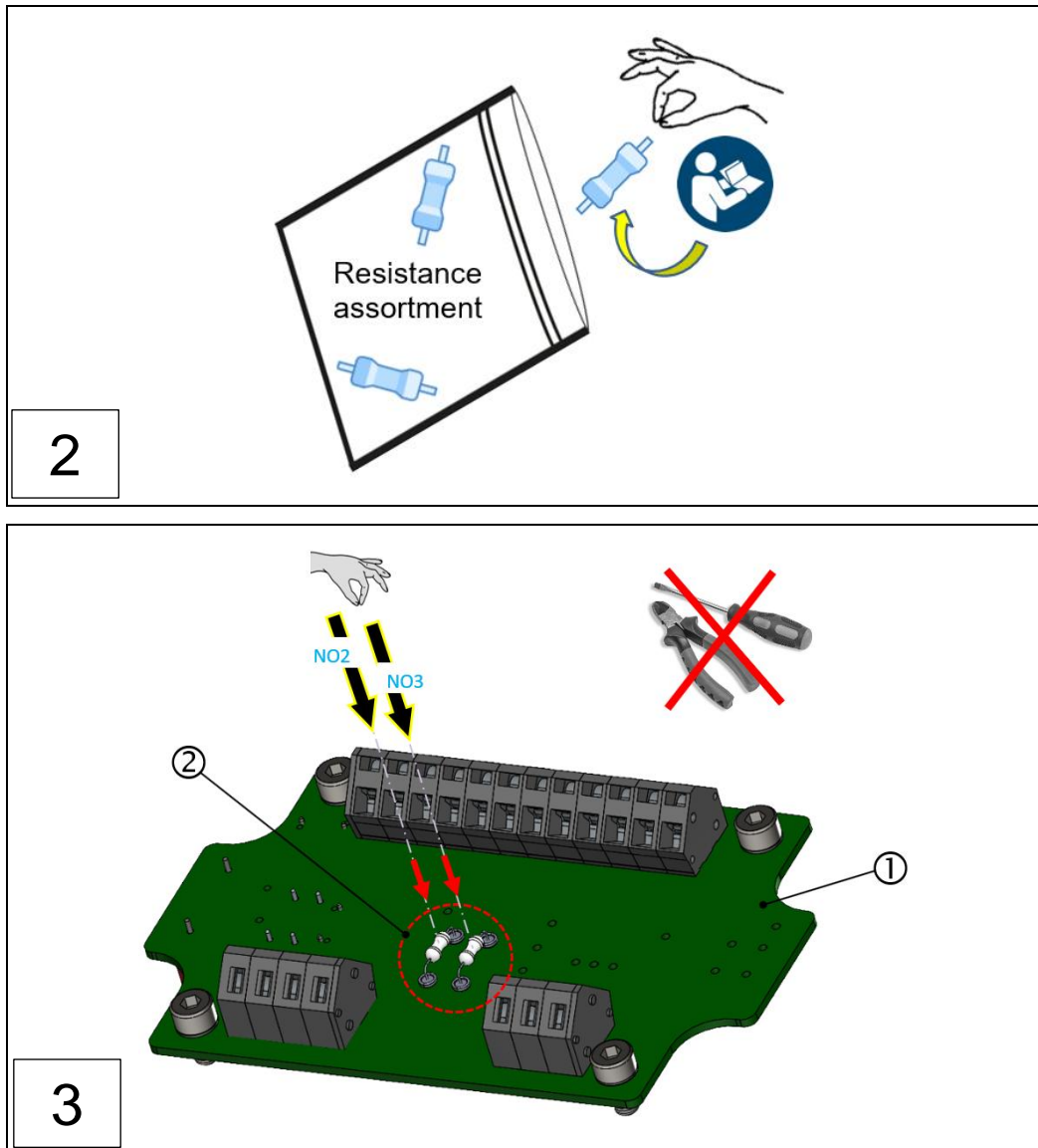

Fig.: 45 : VN2020 terminal box: Inserting the wire break resistors (installation steps 1-3)

1: Connection board, VN2020 terminal box

2: Wire break resistors, VN2020 terminal box

6.4.2.2 Electrical installation of the VN2020 terminal box

⇒ Section 6.4.2 Electrical installation of the terminal box VN2020 series

All the electrical terminal connections are on the connection board of the terminal box, to which the free cable ends of the relay and alarm supply lines that are already prepared and the power supply are connected.



WARNING

Failure to comply with the safety instructions may result in major damage to property or the environment and in serious injury or death.

- Familiarise yourself with the basic safety instructions before starting electrical installation. ⇒ Section 2.4 Basic safety instructions

Terminal No.	Terminal	Connect to	Note/action
1	24 V DC +	Power supply	Voltage report: 18-31, 2V
2	24 V DC -		
3	Spare S1		Reserve
4	Spare S2		
5	A/H	Remote indicator	RS485 A/CAN H
6	B/L		RS485 B/CAN L
7	GND		RS485 GND/CAN GND
8	NC1	Alarm system/safety system	Contacts COM1 and NO1 close in Ready mode
9	COM1		
10	NO1		
11	NC2	Alarm system/safety system	Contacts COM2 and NO2 close in the event of an oil mist alarm (High Oil Mist Alarm)
12	COM2		
13	NO2		
14	NC3	Alarm system/safety system	Contacts COM3 and NO3 close in the event of an oil mist alarm (High Oil Mist Alarm)
15	COM3		
16	NO3		
17	NC4	Alarm system/safety system	Contacts COM4 and NO4 close in the event of a pre-alarm (Oil mist pre-alarm). Pre-alarm is triggered from 70% of the high oil mist alarm threshold.
18	COM4		
19	NO4		

Fig.: 46 : Terminal assignment diagram, terminal box for VN2020

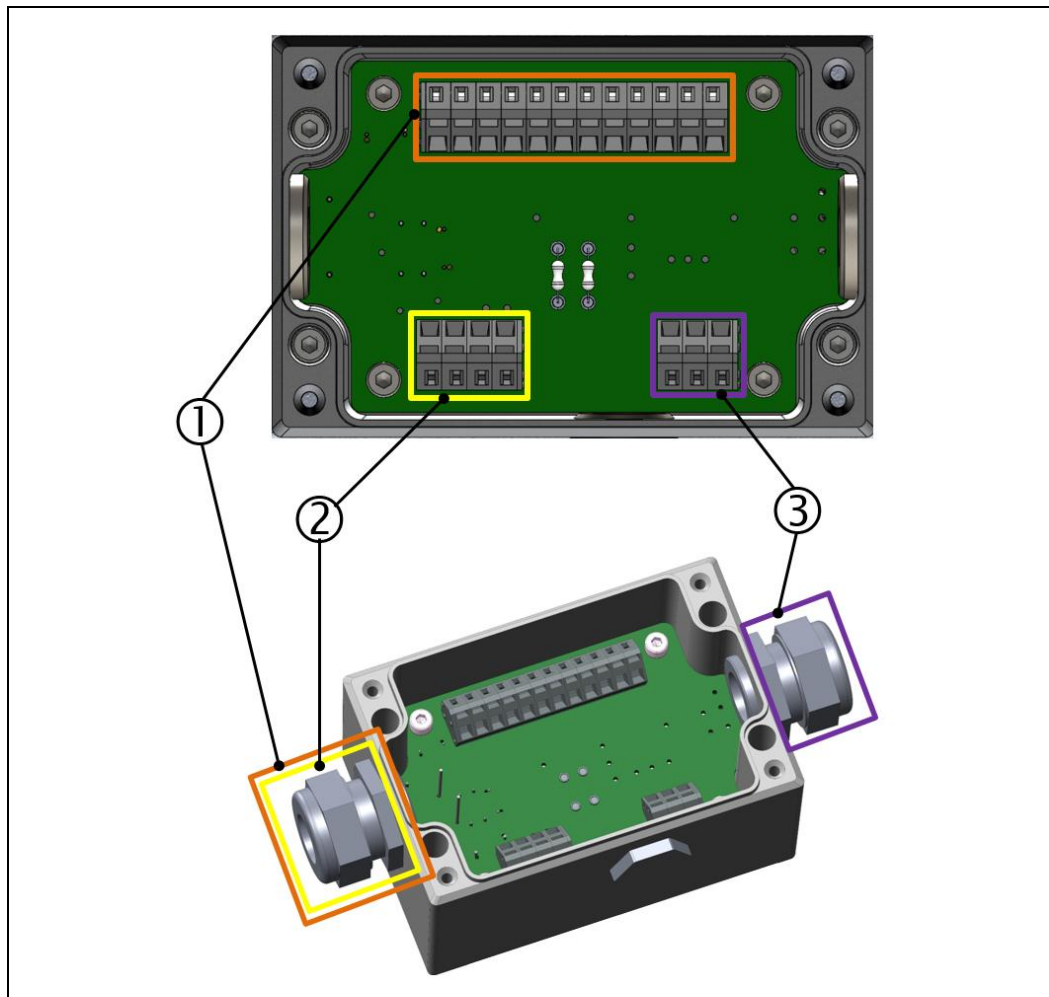

Fig.: 47 : Electrical connection terminal box (example installation), VN2020

1: "Relay" terminal strip

2: "Power supply 24V" terminal strip

3: "Remote indicator" terminal strip

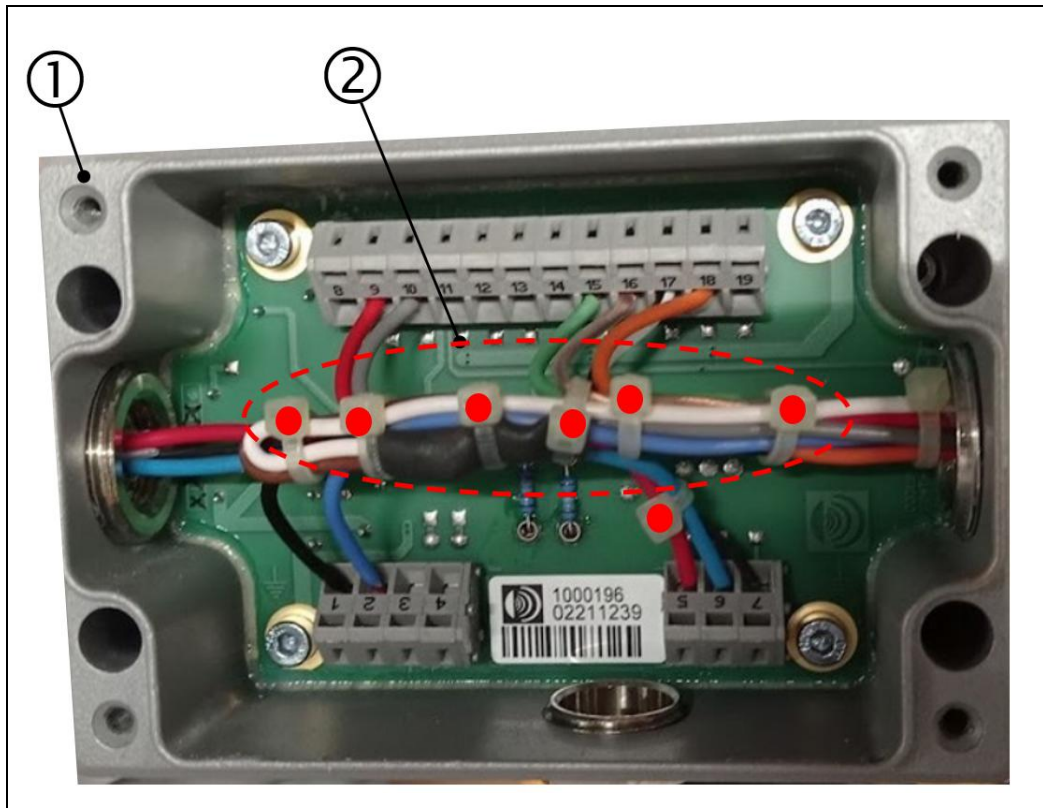
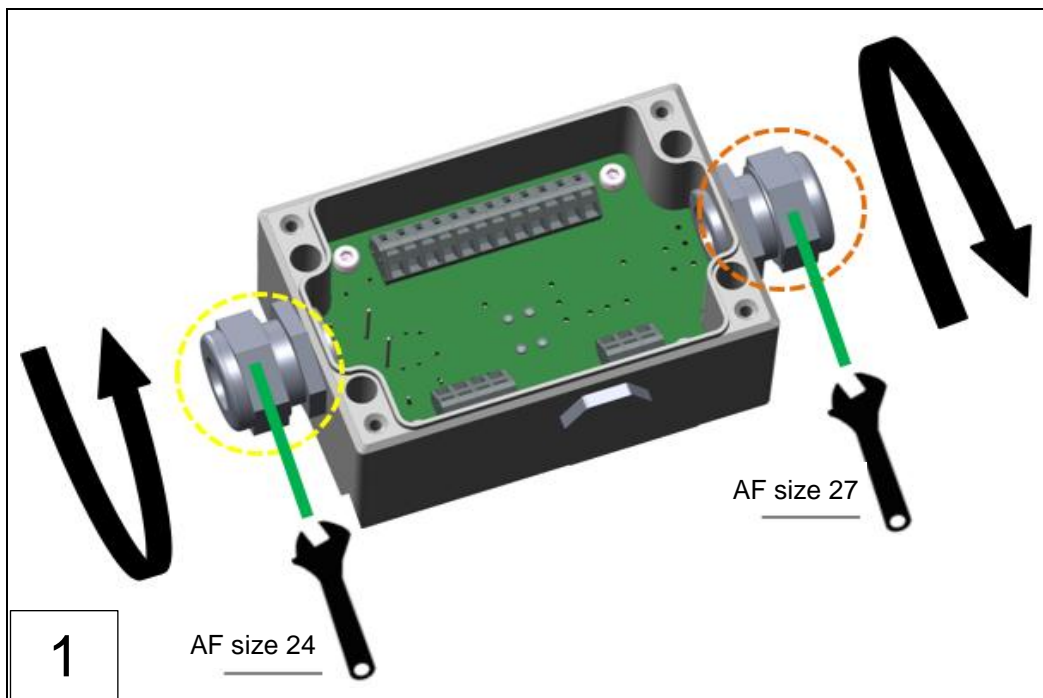
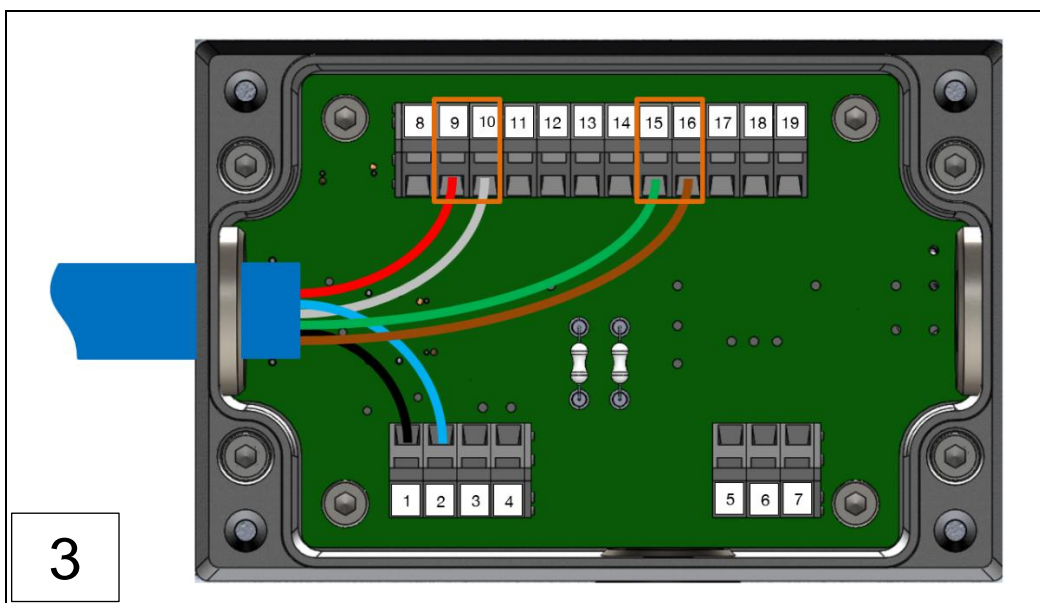
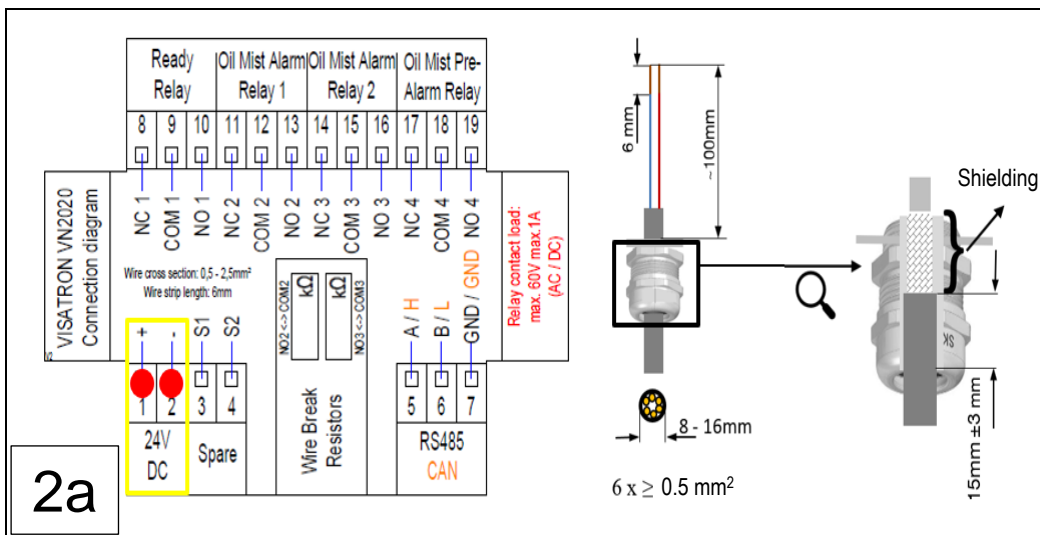
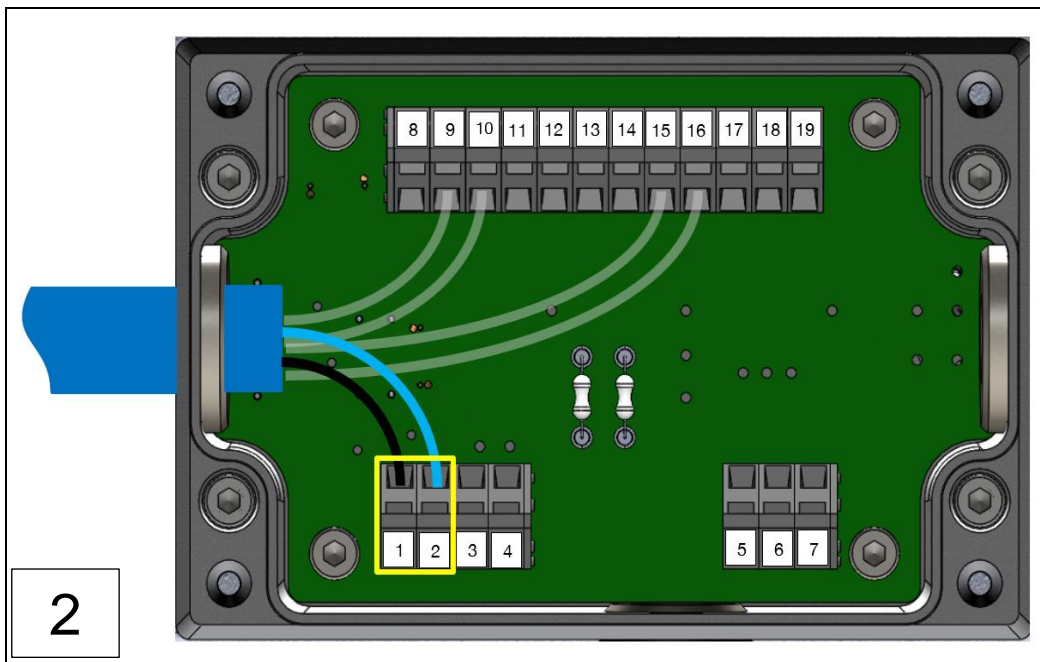

Fig.: 48 : Recommended electrical installation, terminal box for VN2020

1: Terminal box, VN2020

2: Recommended electrical installation with cable ties





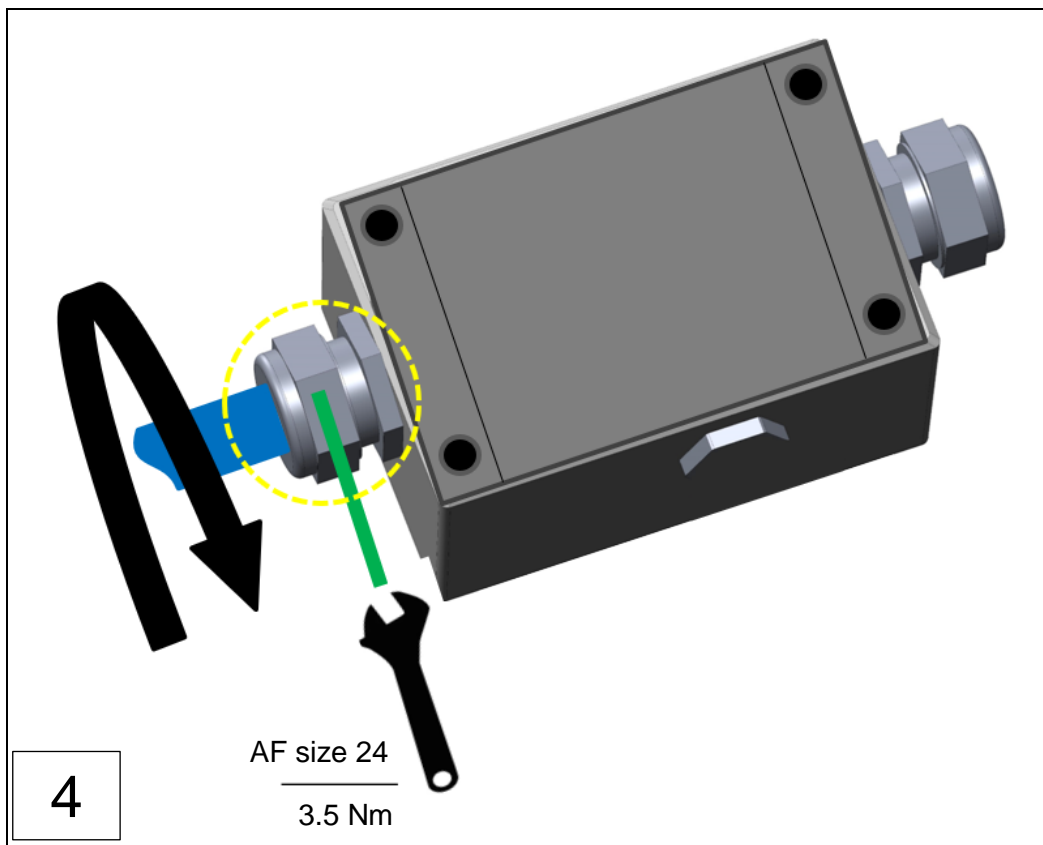
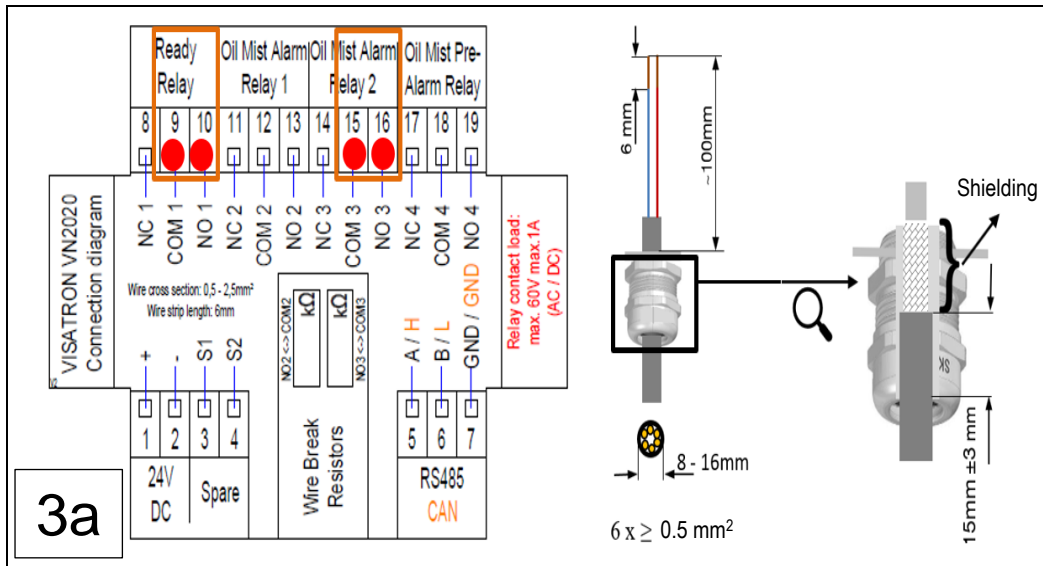

Fig.: 49 : Establishing the power and relay supply (example installation; installation steps 1-4)

6.4.3 Electrical connection of the Remote Indicator II (optional)

⇒ Section 6.4.2 Electrical installation of the terminal box VN2020 series

The VISATRON® VN2020/ VN2020 EX system can be connected to the Remote Indicator II for remote monitoring to monitor the oil mist concentration and the system status from a safe location according to IACS UR M10.

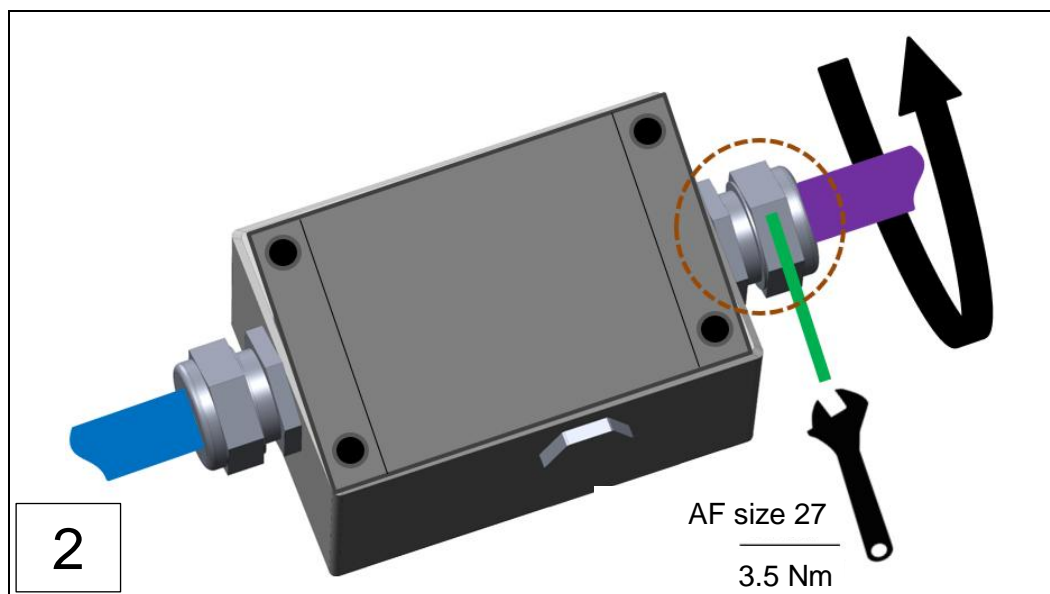
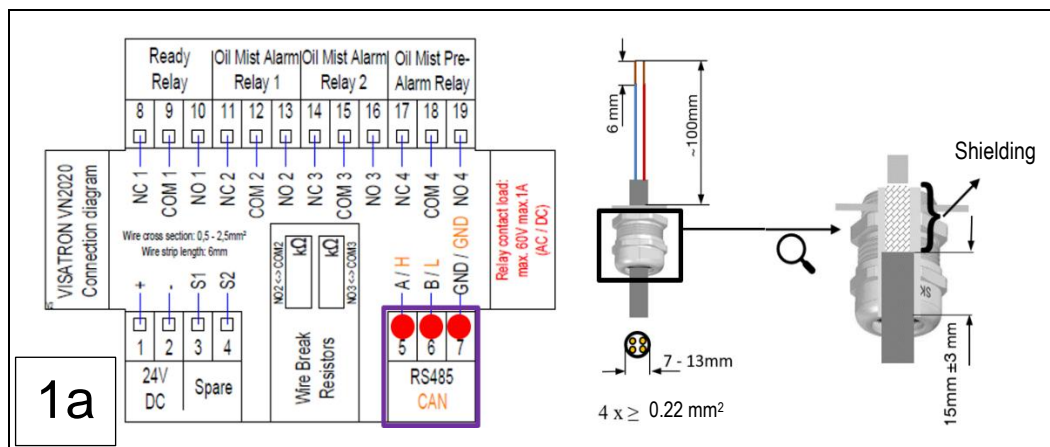
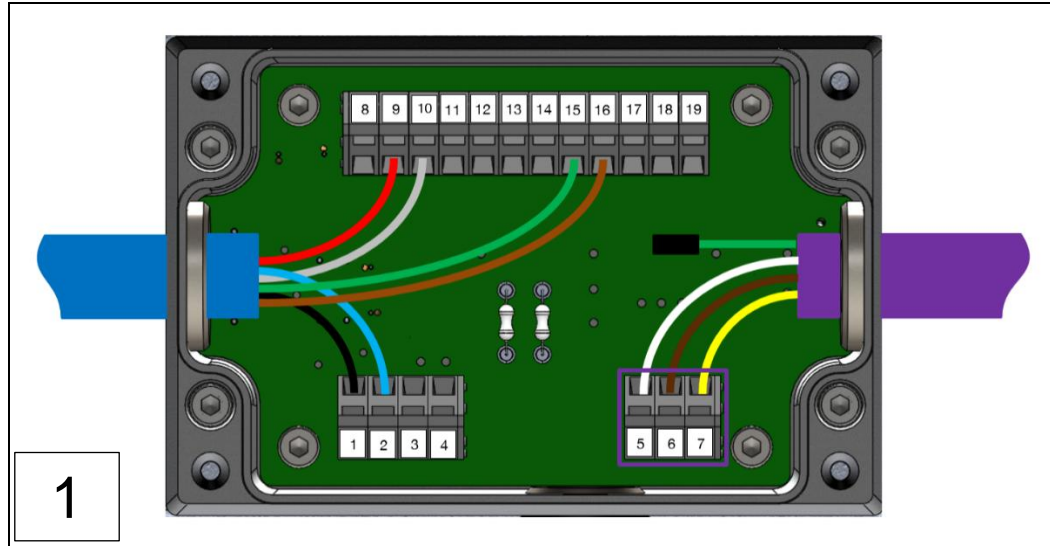

Fig.: 50 : Connecting the Remote Indicator II to terminal box (example inst.; install. steps 1-2)

The monitoring devices are connected via a RS485 bus line. If a Remote Indicator II is used, the connection only consists of a two-point connection. When the oil mist detector is delivered, the bus system is terminated with a switchable resistor as standard, which is always set to the "ON" position at the factory. This is positioned in the measuring head as shown in the figure below:

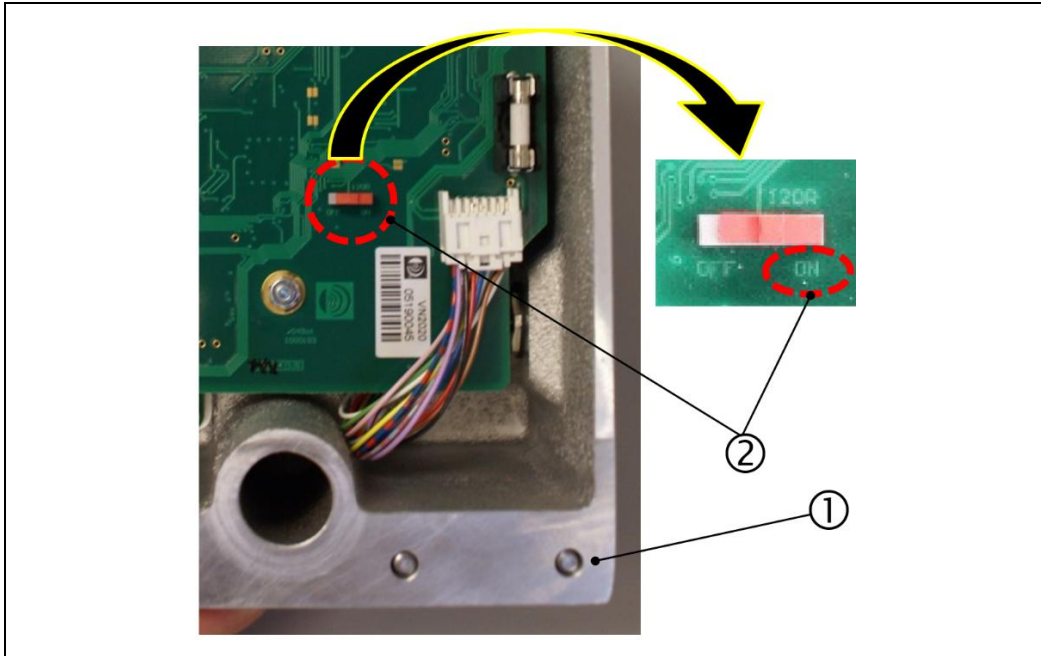

Fig.: 51 : Connection board for VN2020 measuring head

1: VN2020 measuring head

2: Termination resistor (switchable)

Use a communication cable with a twisted and shielded 3-wire cable, such as:

- LAPP UNITRONIC-FD CP (TP) plus UL-CSA CABLE.
- Maximum cable length: 400 m

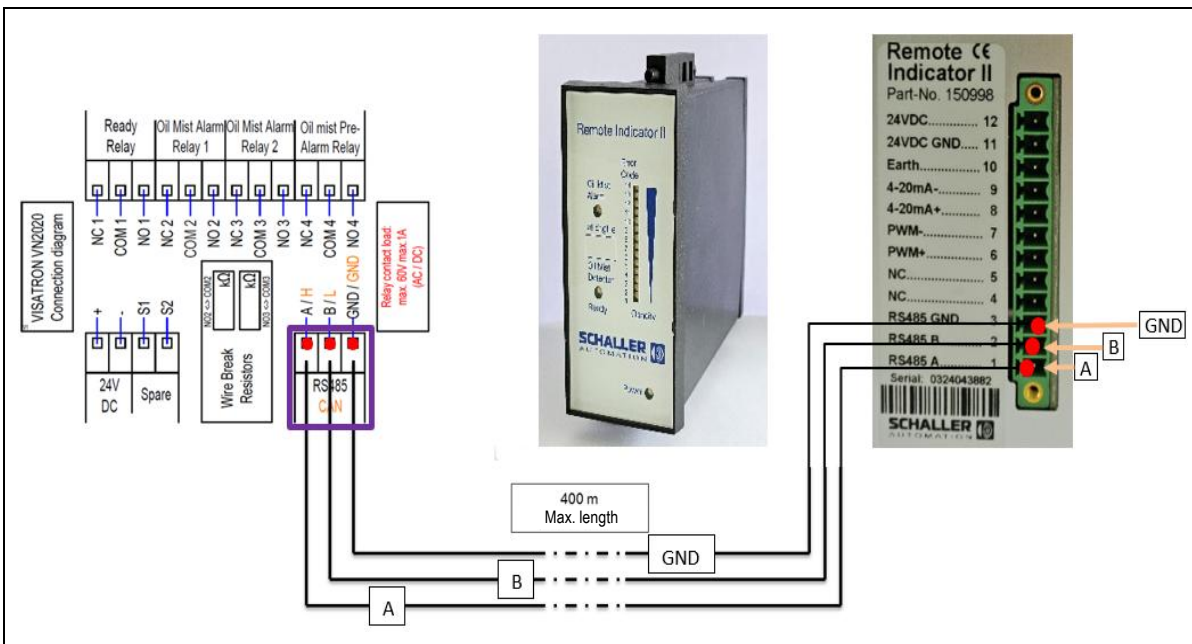

Fig.: 52 : Remote Indicator II (optional); installing contacts

6.4.4 Closing the terminal box after completing the electrical installation

After the electrical installation, the terminal box on the VN2020 is fitted back on as shown in the figure below and then closed. Tighten the screws **crosswise**.

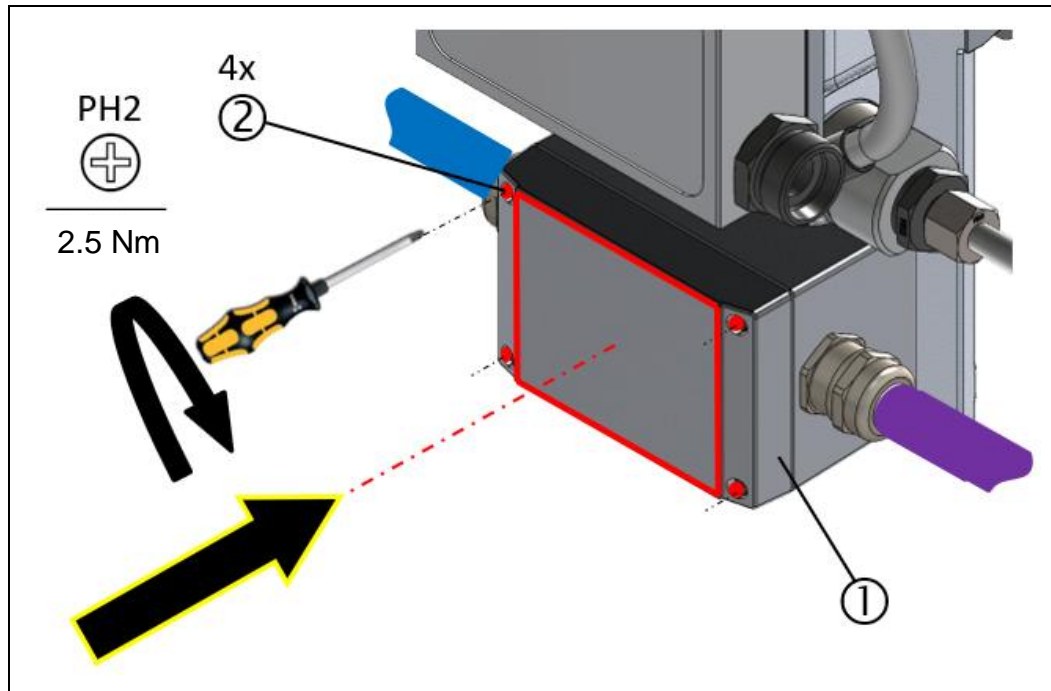

Fig.: 53 : Closing the terminal box for VN2020

1: Cover, VN2020 terminal box

2: Fixing screws

6.4.5 Connecting housing earth to the protective cover of the VN2020

⇒ Section 2.4 Basic safety instructions

DANGER

Electrical hazards

- ▶ The VISATRON® VN2020 must be disconnected from the power supply first, as soon as the housing is earthed between the protective cover of the device and the engine.



The earth connection between the oil mist detector (protective cover) and the engine is via an earth connection with a permanent corrosion-free screw connection, as per the figures below:

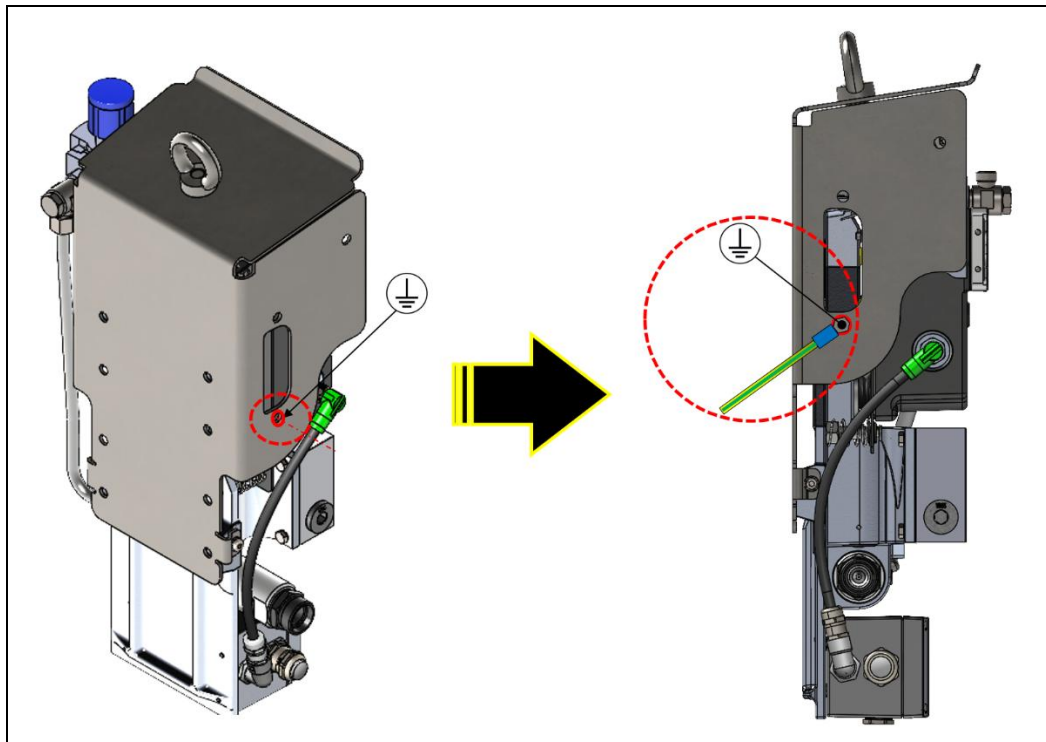

Fig.: 54 : Position and installation, earth connection and protective cover for VN2020

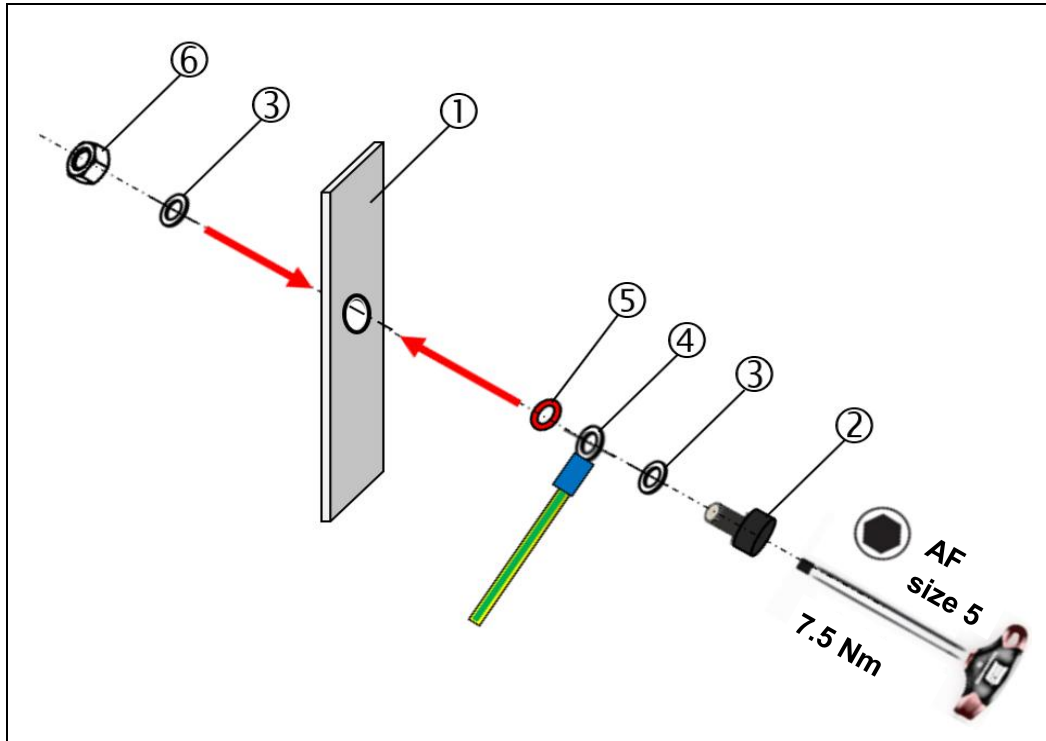

Fig.: 55 : Installing the earth connection, VN2020

- | | |
|--------------------------------------|---|
| 1: Protective cover VN2020 (cut-out) | 4: Earthing cable with ring eye DN6 (customer-specific) |
| 2: M6 screw DIN912, galvanised | 5: Contact washer M6 with teeth |
| 3: x2 Schnorr washers | 6: Hexagon nut M6, galvanised |

6.5 Starting up for the first time



WARNING

Risk of oil mist explosion

Engine protection not guaranteed!

- ▶ The oil mist detector may only be started up after all the components have been completely attached
- ▶ To establish protection of the engine, start up the oil mist detector for the first time with the engine stopped.

Failure to comply with the safety instructions may result in major damage to property or the environment and in serious injury or death.

- ▶ Familiarise yourself with the basic safety instructions before starting electrical installation. → *Section 2.4 Basic safety instructions*
- ▶ If the oil mist detector is operated in explosion-proof areas, the relevant safety instructions must be observed. → *Section 2.4.1 Safety instructions for potentially explosive atmospheres*



CAUTION

Safe and proper use of the device

- ▶ Read the operating manual and other documents that accompany the product carefully and keep them in a suitable place for future reference.
- ▶ For repair and service work, you must follow the instructions in the operating manual.



NOTE

Personal protective equipment

Operating the device or working on the device without protective equipment may result in serious injury. For the workplace PPE, the following protective equipment must be used:

- ▶ DIN EN 388:2016 Protective gloves against mechanical risks, 2341X, and DIN EN 407:2004 Protective gloves against thermal risks, X1XXXX
- ▶ Safety glasses in accordance with DIN EN 166 or DIN EN 170
- ▶ Safety helmet in accordance with DIN EN 397 and DIN EN 50365
- ▶ ESD safety shoes according to ESD standard DIN EN 61340-5-1

6.5.1 Checklist for starting up for the first time

If the assembly (\Rightarrow Section 6.3 *Assembling the system components*) and the installation (\Rightarrow Section 6.4 *Electrical installation*) of the oil mist detection system have been completed successfully, we recommend working through the following checklist **before** starting up for the first time:

Item No.	Description	<input checked="" type="checkbox"/>
1	Are all lines and pipes installed as shown in the installation drawing?	
2	When using or after installing siphon blocks: Are all siphon blocks filled with oil and all unused openings closed?	
3	When using or after installing pipe siphons: Are all the pipe siphons filled with oil?	
4	Is the negative pressure at the measuring head set to 60 mmWC?	
5	Are all electrical lines and cables properly and safely routed or tucked away?	
6	Has the optional housing earthing been correctly established on the device's protective cover?	
7	Have the correct wire break resistors in the measuring head been adapted to the specifications of the applicable engine manufacturer? (default on delivery: 33 kOhm)	
8	Are all the threaded connections tightened to the specified torque?	
9	Is the power supply correctly connected in the terminal box and is the voltage within the specified range?	
10	Is the Remote Indicator II for remote monitoring properly mounted and installed? (only applies if the optional accessories have been purchased)	
11	Are the "Alarm" and "Ready" signals connected to the engine control and safety system?	
12	Functional test performed with smoke tube?	
13	After the visual inspection, close all the covers that are still open.	

Table 11 : Checklist for startup

6.5.2 Connecting the power supply

The power supply has been made available in advance by the operator and installed according to Section 6.4.2. ⇒ Section 6.4.2 Electrical installation of the terminal box

1. Switch on the power supply for the oil mist detector.
 - ▶ Activates the power supply provided by the customer.



NOTE

When the VISATRON® VN2020/VN2020 EX is ready for operation

- ▶ When the power supply is switched on, the “System failure” and “Air supply failure” LEDs (①) come on yellow on the display and the oil mist detector counts down for 30 s (②).
- ▶ Once the time has elapsed and as soon as the system check has been successfully completed **and** a negative pressure of 60 mmWC ± 5 mmWC has been set, the device is ready for operation and the “System ready” (③) LED on the display and the LED for “Relative oil mist concentration” (④) turn green.
- ▶ If the LEDs do not come on as described above, please continue reading in Section 10. ⇒ Section 10 Error diagnosis and troubleshooting

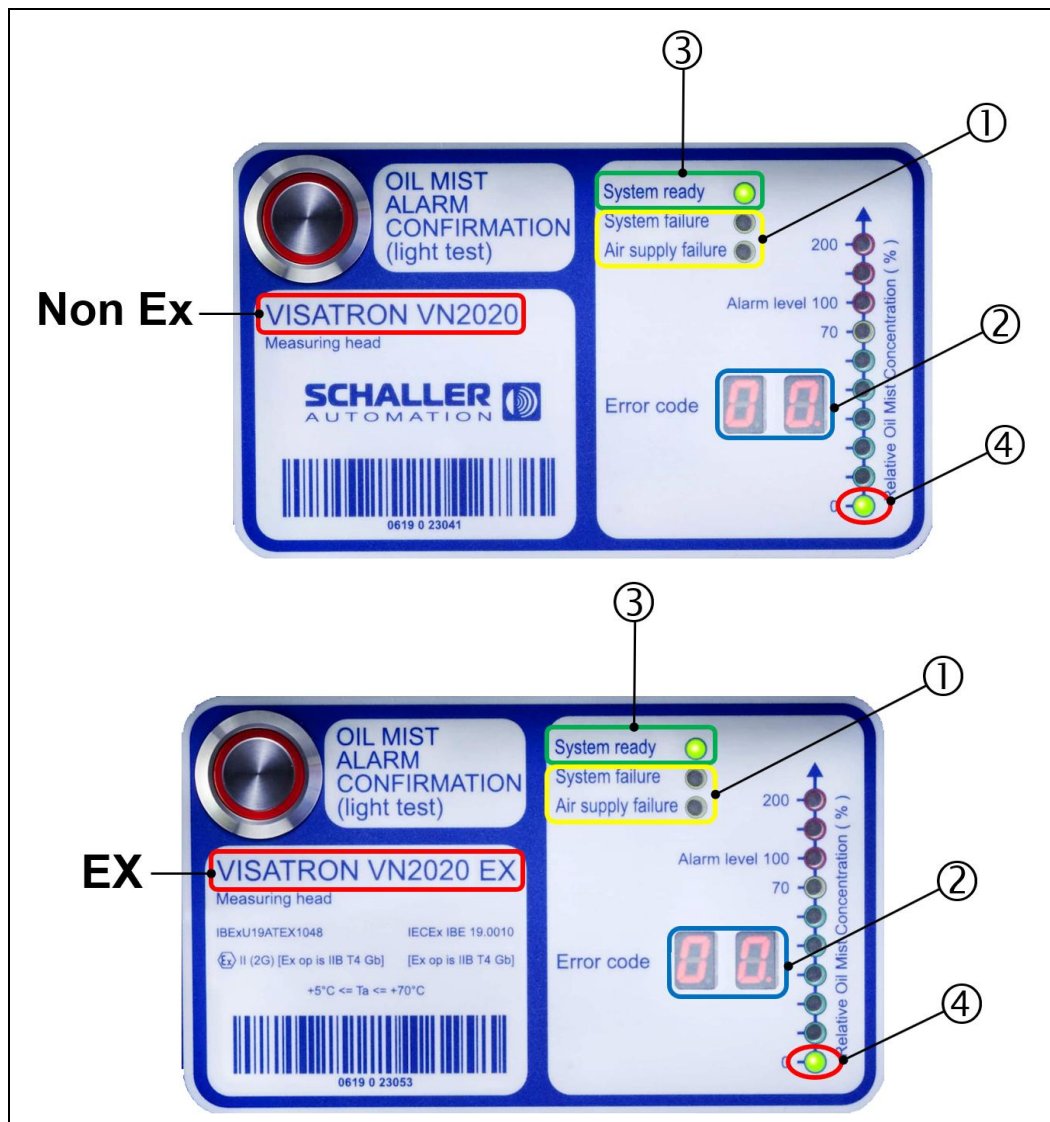

Fig.: 56 : “System ready” indicator on the VN2020/VN2020 EX measuring head

6.5.3 Setting the negative pressure at the measuring head of the VN2020/VN2020 EX

NOTE



Early error message on the measuring head

- ▶ The VN2020 service box is needed in order to set the negative pressure. (Schaller Order No.: 151906) ⇒ Section 13.1.2 Service box for VN2020/VN2020 EX
- ▶ The negative pressure to be set at the measuring head is 60 mmWC ± 5 mmWC.
- ▶ Please comply with the safety instructions in Section 6.5 for the work described below.
⇒ Section 2.4 Basic safety instructions
- ▶ To ensure the device functions correctly after setting the device pressure: Make sure that at least **one crankcase cover of the engine** is open to prevent any influence of crankcase pressure on sampling pressure.



CAUTION



Risk of injury from setting the sampling pressure

- ▶ The sampling pressure of the oil mist detector is set by adjusting the filter control valve and may only be adjusted when the engine is at a standstill.
- ▶ To prevent the risk of injury, the negative pressure at the measuring head must be set within the specified limit values:
55 ≤ mmWC ≤ 65

The negative pressure is set as follows:

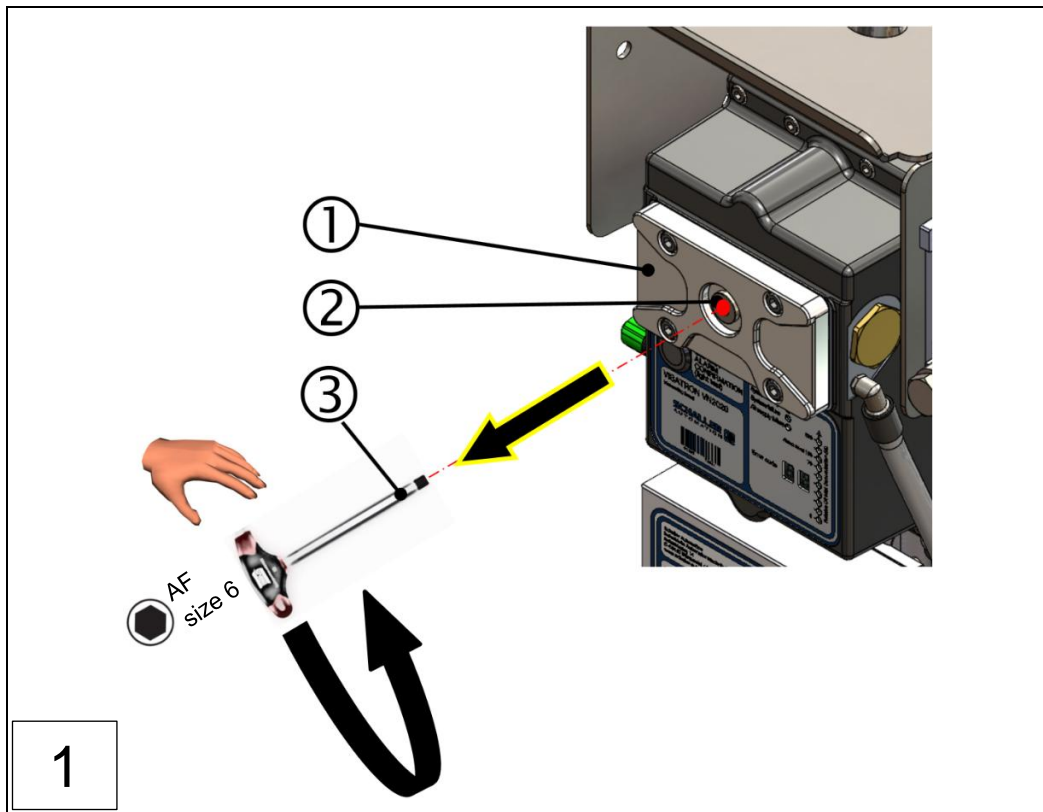

1: Inspection cover
3: Allen key, size 6

2: Screw plug

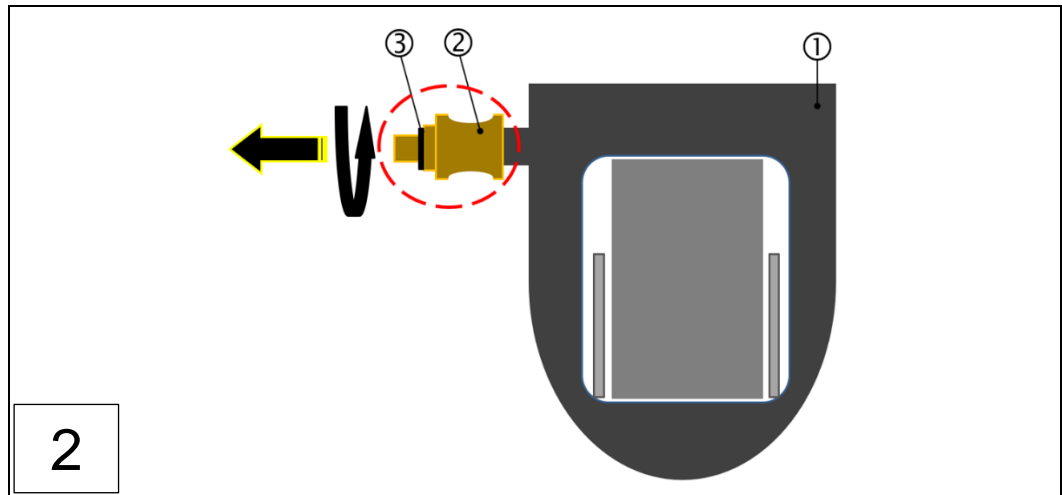

1: U-tube manometer (accessory) 2: Quick-release coupling
3: Sealing ring

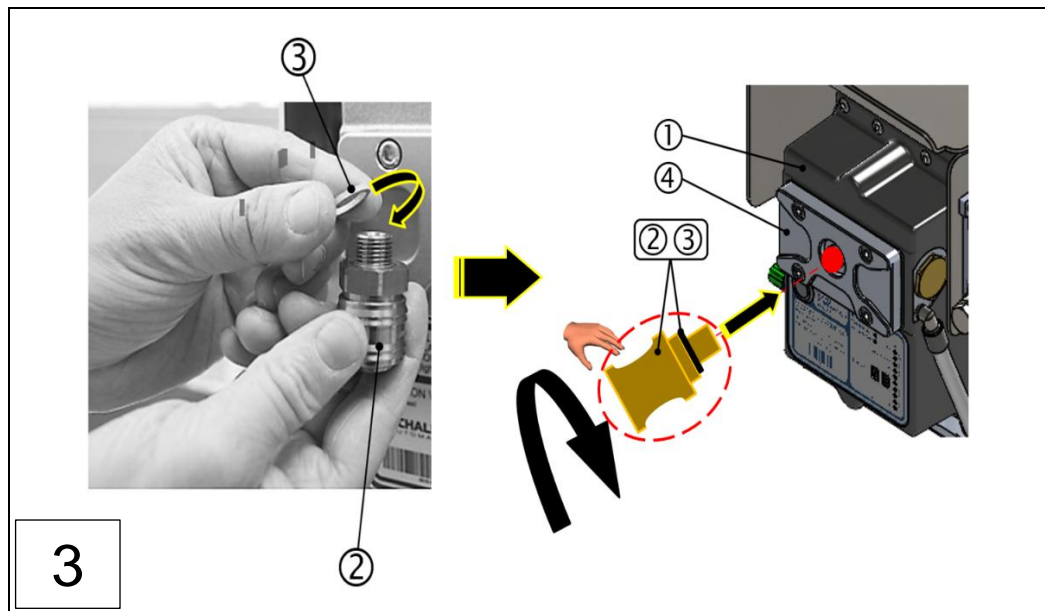

1: Measuring head 2: Quick-release coupling
3: Sealing ring 4: Inspection cover

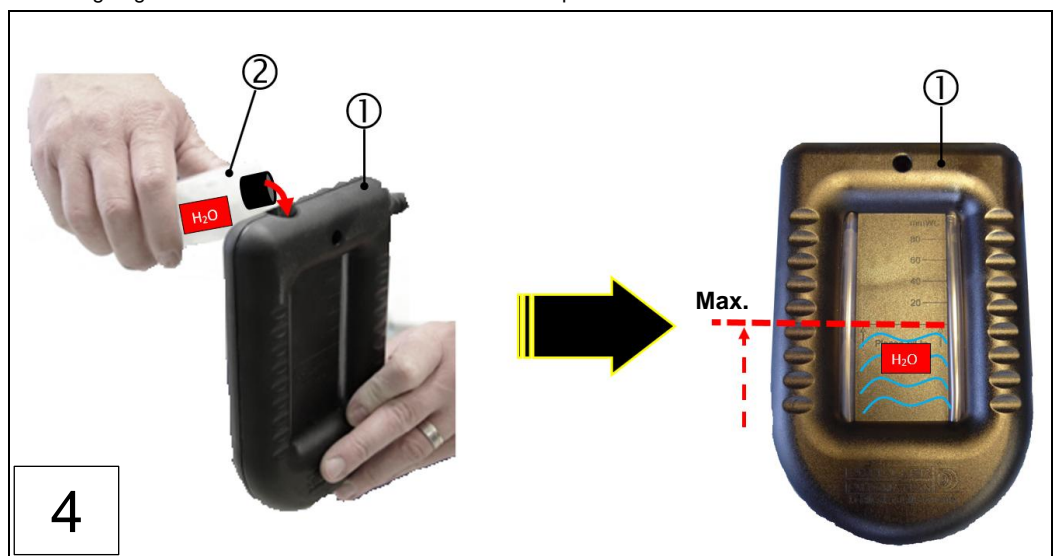

1: U-tube manometer 2: Bottle with low surface tension water

2. Switch on the central compressed air supply, which was previously installed and connected to the device by the operator in accordance with Section 6.1.1.
⇒ Section 6.1.1 Establishing the compressed air supply
3. Set the supply pressure on the device. This pressure must be between **2 bar and 14 bar**.
 - ▶ Unlock the blue adjusting cap (②) on the pressure regulator, i.e. push it upwards.
 - ▶ Turning the blue adjusting cap (②) anticlockwise reduces the pressure, turning it clockwise increases the pressure, thereby setting the water column on the U-tube manometer (③).
 - ▶ Set the allowed water column on the U-tube manometer (③) to **60 mmWC ± 5 mmWC**.



- ▶ Push the blue adjusting cap (②) on the pressure regulator (①) down again to lock it.

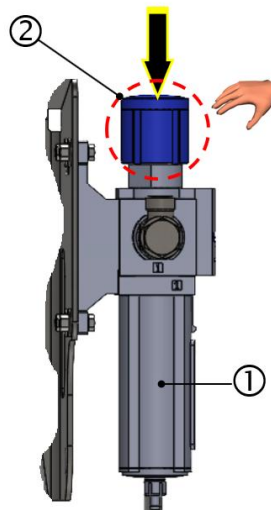

4. Once installation step 6 has been completed successfully, carry out installation steps 1-5 in reverse order.
 - ▶ If it was not possible to set the negative pressure correctly as per installation step 6, please continue reading in Section 10. ⇒ Section 10 Error diagnosis and troubleshooting
5. Screw the screw plug (③) from installation step 1 back in, to a torque of 15 Nm.

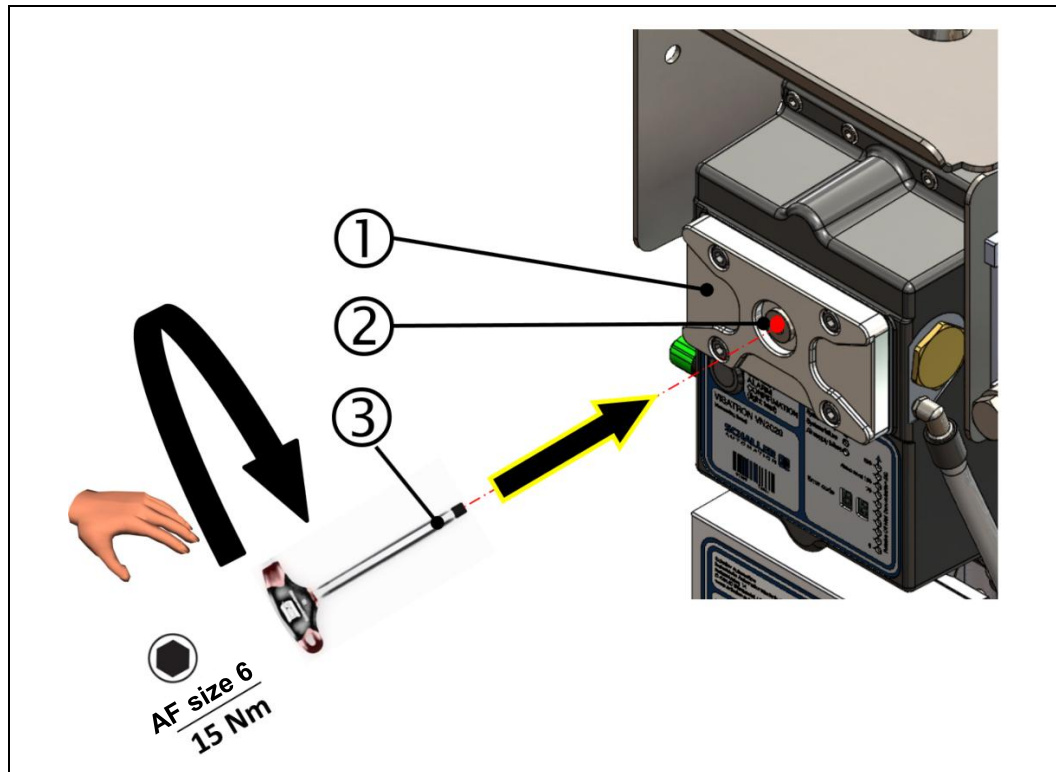

Fig.: 58 : Screwing in the screw plug on the measuring head of the VN2020/VN2020 EX

- 1: Inspection cover
 2: Screw plug
 3: Allen key, AF size 6/(torque spanner for up to 15 Nm)

The negative pressure on the measuring head has been set successfully and the device is now ready for operation again!

6.5.4 Setting the sensitivity on the VN2020/VN2020 EX oil mist detector

The oil mist detector determines the oil mist concentration by optical measurement. The calculated value is the opacity in percent. 100% opacity means that no more light penetrates through the oil mist sample because of maximum turbidity.

The lower explosive limit (LEL) to an oil mist concentration of 47 mg/l in the air at a temperature of 25 °C. The regulations of IACS UR M67 require that oil mist detectors output an oil mist alarm at approx. 2.5 mg/l at the latest. The lowest sensitivity of all VN2020 oil mist detectors, sensitivity setting 7, still ensures that an oil mist alarm is output at oil mist concentrations < 2.5 mg/l. This fully complies with the requirements of IACS UR M67.

NOTE

Setting the sensitivity on the oil mist detector

- ▶ The customer is responsible for deciding on the sensitivity of the oil mist detector. The oil mist detector is set to sensitivity **level 2** at the factory.
- ▶ To change the sensitivity of the oil mist detector, follow the complete instructions for the VN2020 End User Software. They are available on the DVD, which is included in the delivery.





WARNING

Setting the sensitivity on the oil mist detector

- ▶ Familiarise yourself with the basic safety instructions before starting electrical installation. ⇒ Section 2.4 Basic safety instructions
- ▶ If the oil mist detector is operated in explosion-proof areas, the relevant safety instructions must be observed. ⇒ Section 2.4.1 Safety instructions for potentially explosive atmospheres

The following table illustrates the assignment of the set sensitivity against the relative opacity.

VN2020 Sensitivity setting [Sensitivity]	Oil mist concentration alarm level [mg/l]	Opacity alarm threshold [%]
1	0.55	1.50
2 (Default factory setting)	0.70	2.00
3	0.90	2.50
4	1.10	3.00
5	1.40	4.00
6	1.80	5.00
7	2.50	7.00

Table 12 : Assignment table (sensitivity/opacity)

Once the end-user software has been installed and configured on your PC/laptop and a data connection to your oil mist detector has been established, the sensitivity of the oil mist detector can be set on the PC/laptop as shown in the figure and steps below:

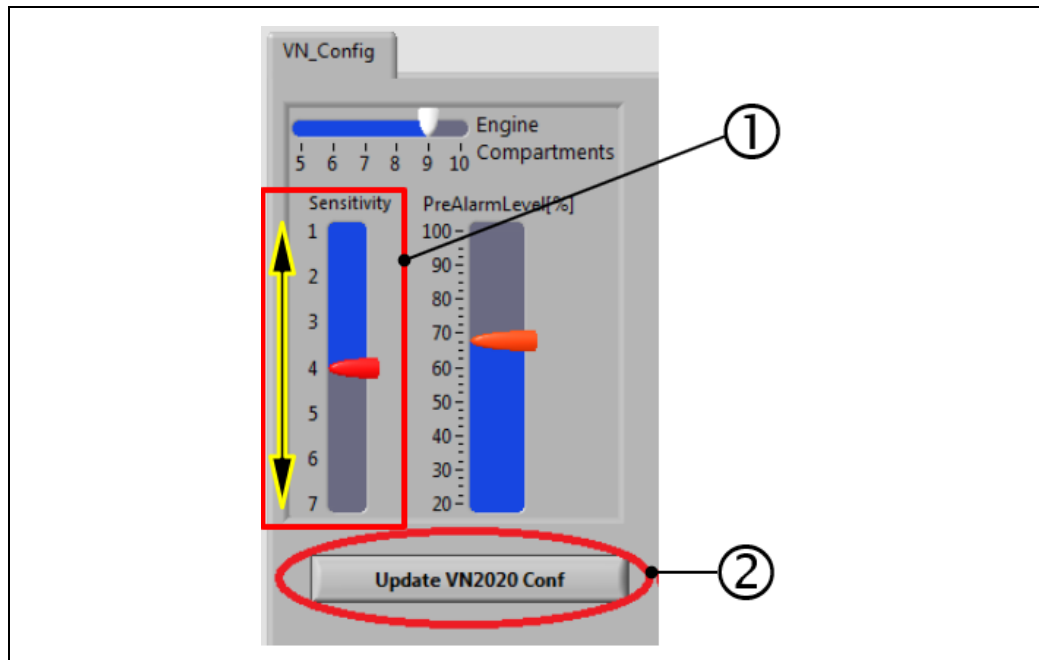

Fig.: 59 : Setting the sensitivity

1: "Sensitivity" indicator

2: "Update VN2020 Conf" button

1. Changing the sensitivity
 - ▶ Move the position arrow under “Sensitivity” (①) to the position you want. In the example above, the sensitivity has been changed to level 4.
2. Once the sensitivity has been changed, a button with the label “Update VN2020 Conf” is displayed on the control panel. (②)
3. Left-clicking [Enter] on the button transfers the changed settings to the VN2020.
4. Once the “Update VN2020 Conf” button has been pressed, the button is hidden and the new sensitivity setting applies.

6.5.5 Function test when starting up for the first time



 WARNING	
<p>Risk of oil mist explosion Engine protection not guaranteed!</p> <ul style="list-style-type: none"> ▶ The oil mist detector may only be started up after all the components have been completely attached ▶ To establish protection of the engine, start up the oil mist detector for the first time with the engine stopped. <p>Failure to comply with the safety instructions may result in major damage to property or the environment and in serious injury or death.</p> <ul style="list-style-type: none"> ▶ Familiarise yourself with the basic safety instructions before starting electrical installation. ⇒ <i>Section 2.4 Basic safety instructions</i> ▶ If the oil mist detector is operated in explosion-proof areas, the relevant safety instructions must be observed. ⇒ <i>Section 2.4.1 Safety instructions for potentially explosive atmospheres</i> 	



IMPORTANT INFORMATION	
<p>Using smoke tubes correctly</p> <ul style="list-style-type: none"> ▶ The smoke tubes approved for use have an expiry date and must therefore be used at the latest within 3 months of delivery. ▶ Smoke tubes that have already reached their expiry date must be properly disposed of. ⇒ <i>Section 11.1 Disposal</i> ▶ Recommended storage conditions: Temperature: 0 °C to 40 °C Humidity: up to max. 70% RH at 40 °C 	

Once the steps in Sections 6.5.1 to 6.5.4 have been successfully completed, you can start the function test.

Please carry out the steps below:

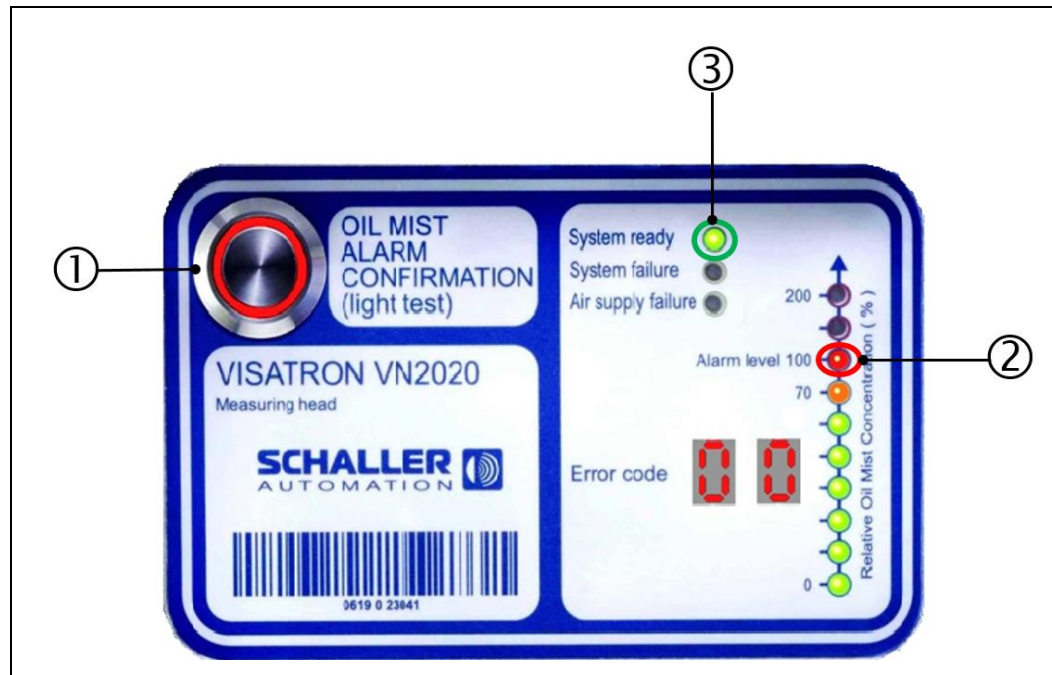

Fig.: 60 : Function test for starting up for the first time, VN2020/VN2020 EX

1: Confirmation button

2: Display; relative oil mist concentration

1. Remove the smoke tubes from the smoke test box (⇒ *Section 13.5 Accessories*) and use them according to the enclosed operating manual.
2. Each suction point is checked separately. To do this, hold the smoke tube directly under the sampling funnel of the specific suction point and perform 3-5 pumping strokes. The resulting smoke should now be drawn out directly via the sampling funnels.
3. After a few seconds (approx. 10s), the alarm is shown on the measuring head display, as in the figure above. The time to display the alarm varies depending on the engine type and assembly configuration.
 - In the event of an alarm, the illuminated ring around the (1) button flashes **red**.
 - At the same time, the “Alarm level 100%” LED (2) in the “Relative oil mist concentration” area turns **red** if the alarm concentration has been exceeded or if there is still smoke in the measuring head.
 - The “System ready” LED (3) stays **green**.
4. Confirm a detected alarm using the (1) button on the measuring head as soon as the relative oil mist concentration is < 70%.
5. Carry out steps 1-4 at all suction points of the installation, thereby ensuring that the whole system is functioning.
6. Dispose of the used smoke tubes as per *Section 11.1* ⇒ *Section 11.1 Disposal*
 - The VISATRON® VN2020 oil mist detector is now ready for operation!**

6.5.6 Factory test by the engine builder with smoke generator on starting up

WARNING

Risk of oil mist explosion

Engine protection not guaranteed!

- ▶ The oil mist detector may only be started up after all the components have been completely installed.
- ▶ To establish protection of the engine, start up the oil mist detector for the first time with the engine stopped.
- ▶ Before starting the on-board test, all the header pipes have to be clean and, if used, all the siphons have to be filled with oil. → *Section 6.3.5 Installing the siphon block assembly*

Failure to comply with the safety instructions may result in major damage to property or the environment and in serious injury or death.

- ▶ Familiarise yourself with the basic safety instructions before starting electrical installation. → *Section 2.4 Basic safety instructions*
- ▶ If the oil mist detector is operated in explosion-proof areas, the relevant safety instructions must be observed. → *Section 2.4.1 Safety instructions for potentially explosive atmospheres*

CAUTION

Safe and proper use of the device

- ▶ Read the operating manual and other documents that accompany the product carefully and keep them in a suitable place for future reference.
- ▶ For repair and service work, you must follow the instructions in the operating manual.

The VN2020/VN2020 EX devices can alternatively be tested by a smoke test. As the test equipment is not normally available on ships, SCHALLER AUTOMATION recommends that this test is only carried out during factory testing with the SCHALLER smoke generator (see figure below).

If there is a smoke generator available on board a ship, this test can also be carried out. However, the following warning must be observed in this case.

The entire oil mist detection system (including lines) can only be tested when the engine is at a standstill.

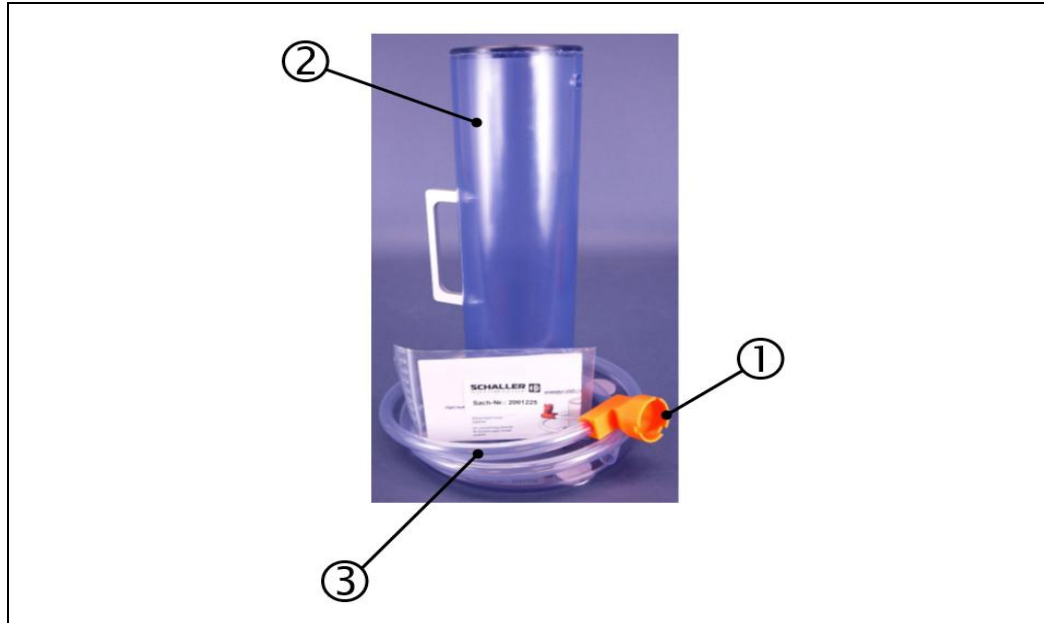

Fig.: 61 : Schaller smoke generator, VN2020/VN2020 EX

- 1: Smoke collection head
- 2: Collection container
- 3: Flexible hose

Once the steps in Sections 6.5.1 to 6.5.4 have been successfully completed or the maintenance covers on the crankcase housing have been opened, you can start the function test.

Based on the figure above, carry out the following steps:

- ▶ Use the smoke generator in accordance with the enclosed operating manual.
- ▶ Pour a small amount of smoke fluid (⇒ *Section 13.5 Accessories*) into the smoke generator's smoke collection head (①) and switch it on for a few seconds until the collection container (②) is completely filled with smoke. This is important in order to ensure that the container can provide enough smoke.
- ▶ Hold the flexible hose (③) directly in the sampling funnel, as shown in the figure below, until an oil mist alarm is displayed.

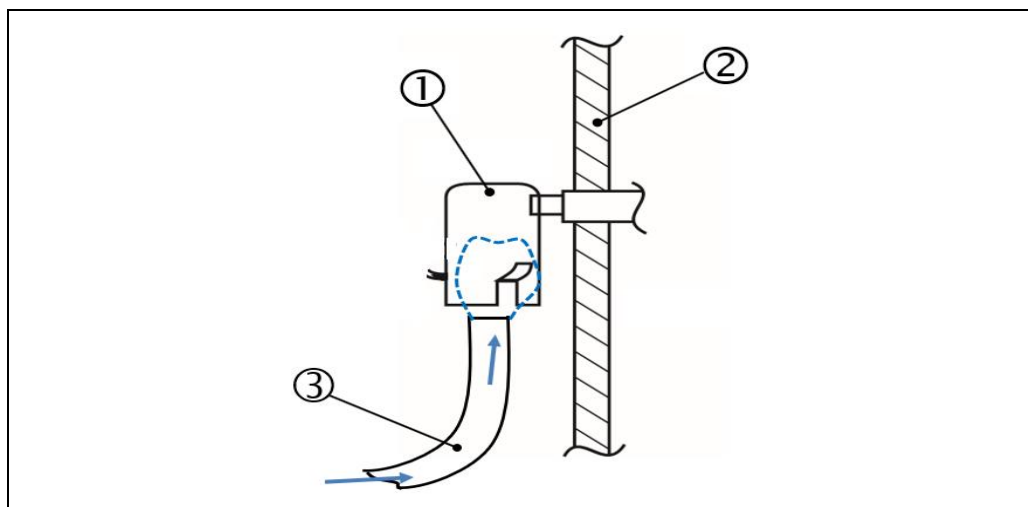

Fig.: 62 : Smoke generator with factory test, VN2020/VN2020 EX

- 1: Sampling funnel
- 2: Engine wall
- 3: Flexible hose

1. Each suction point is checked separately. The resulting smoke should now be drawn out directly via the sampling funnels.
2. After a few seconds (approx. 10s), the alarm is shown on the measuring head display, as in the figure above. The time to display the alarm varies depending on the engine type and assembly configuration.
 - In the event of an alarm, the illuminated ring around the (①) button flashes **red**.
 - At the same time, the “Alarm level 100%” LED (②) in the “Relative oil mist concentration” area turns **red** if the alarm concentration has been exceeded or if there is still smoke in the measuring head.
 - The “System ready” LED (③) stays **green**.

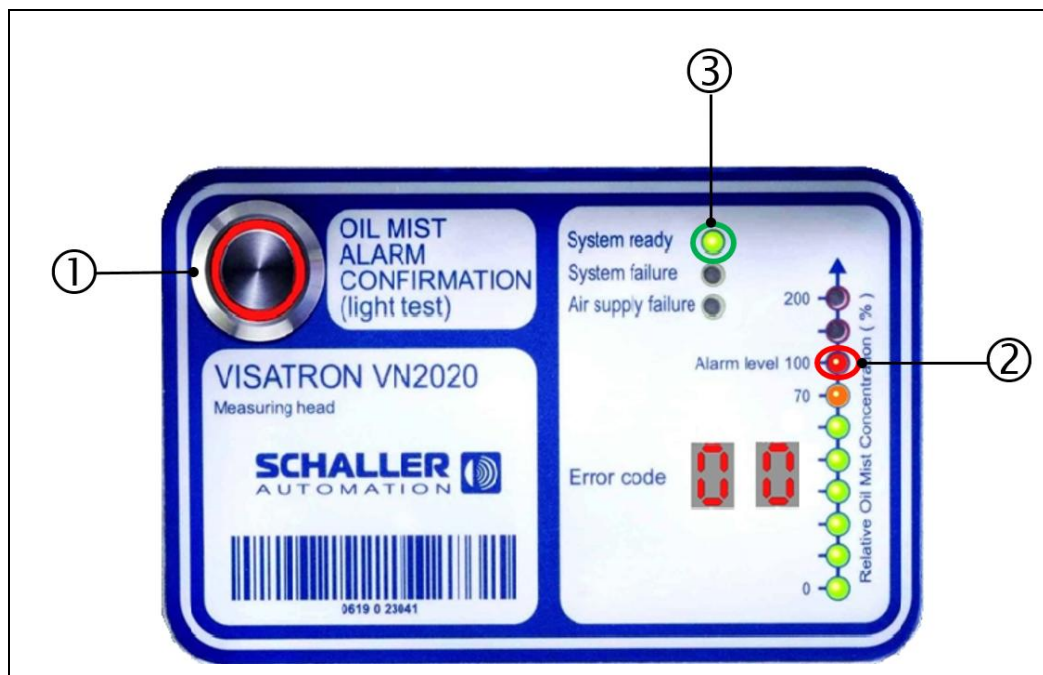

Fig.: 63 : Function test for starting up for the first time, VN2020/VN2020 EX

1: Confirmation button

2: Display; relative oil mist concentration

3. Confirm a detected alarm using the (①) button on the measuring head as soon as the relative oil mist concentration is < 70%.
4. Carry out steps 1-4 at all suction points of the installation, thereby ensuring that the whole system is functioning.
5. Then dispose of the remaining smoke fluid from the smoke collection head (①) of the smoke generator, in accordance with Section 11.1 ⇒ *Section 11.1. Disposal*

The VISATRON® VN2020 oil mist detector is now ready for operation!

Alternative:

If it is not possible to open the maintenance covers, a function test can also be carried out without testing the sampling funnels. In this case, start by removing the screw plug (②) on the siphon block as shown in the figure below:

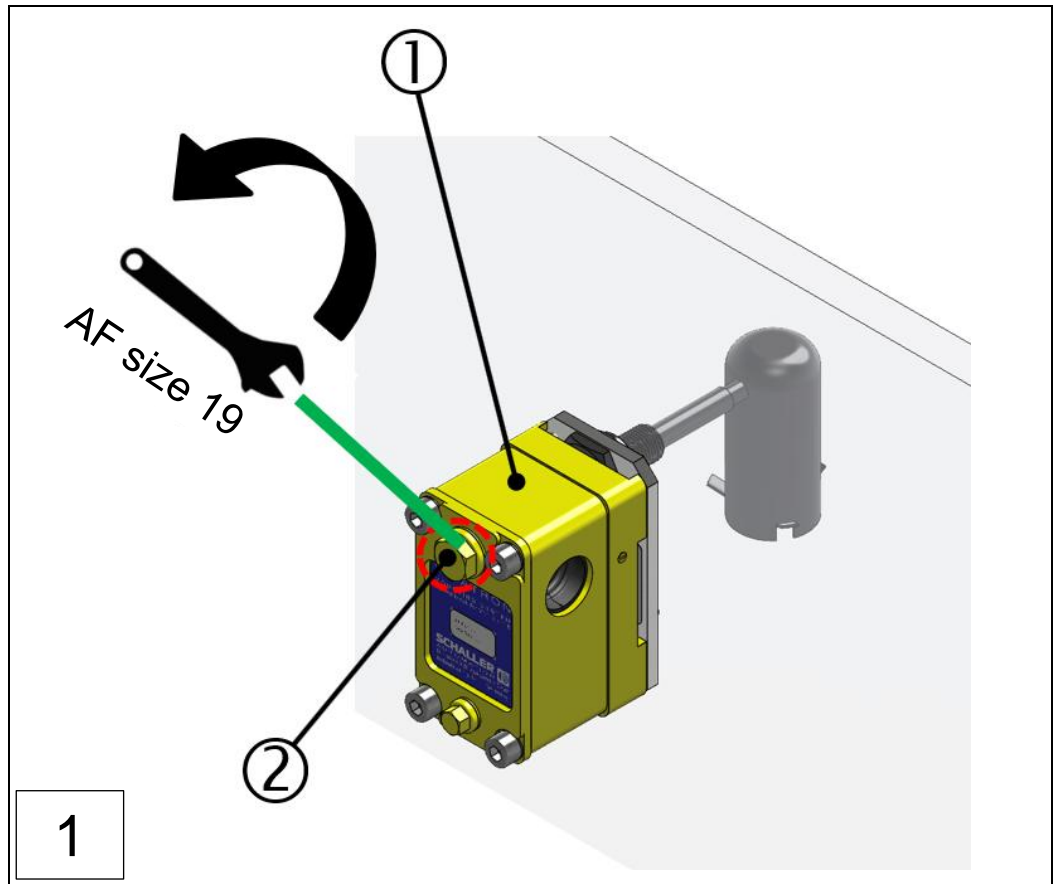

1: Siphon block

2: Screw plug

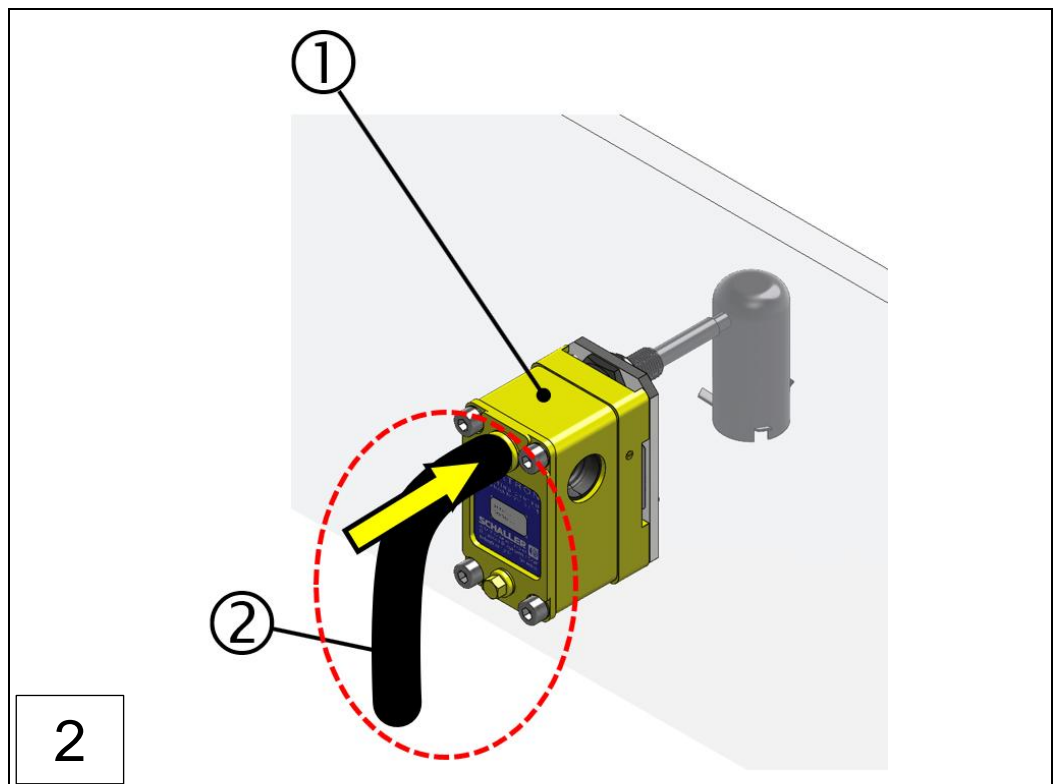

1: Siphon block

2: Flexible hose

- ▶ Press the flexible hose (②) onto the opening (test mist inlet) of the previously removed screw plugs of the siphon blocks, as shown, or onto the open end of the header pipe.
- ▶ Then carry out steps 1-5 (measurement) in this section.
- ▶ Finally, remove the flexible hose again and then close the siphon block with the screw plug (②) or tighten it hand-tight:

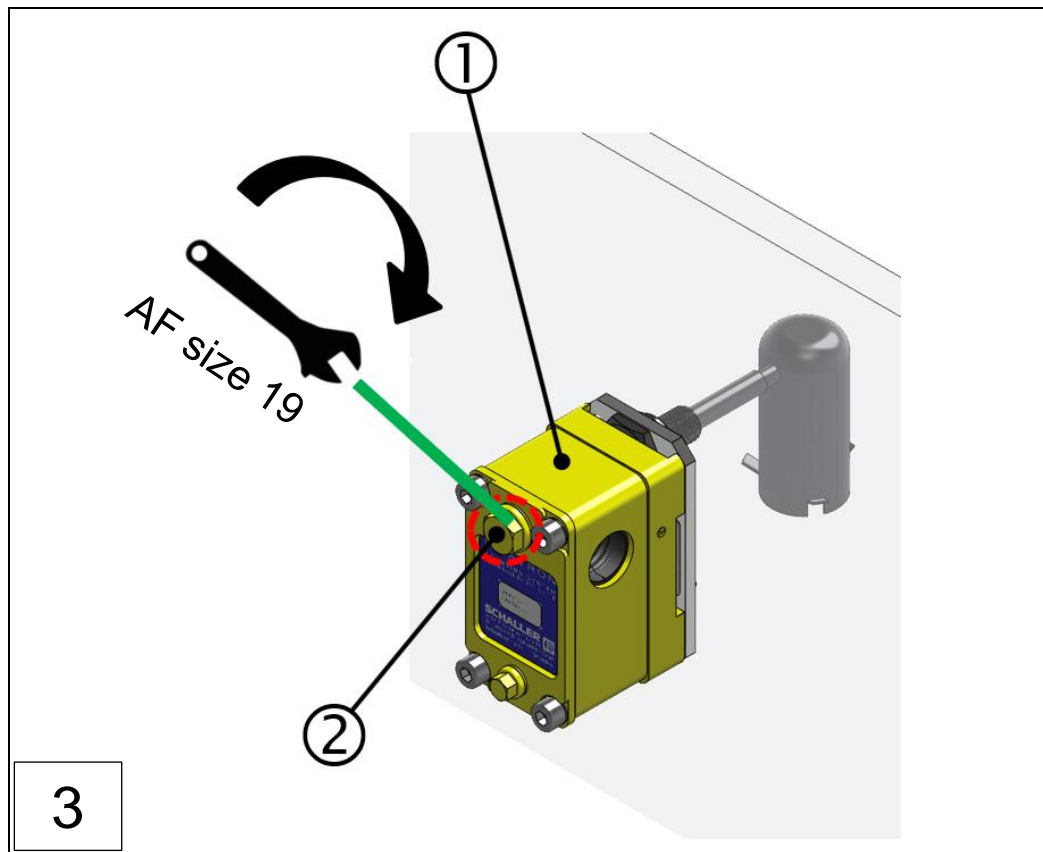

Fig.: 64 : Factory test with smoke generator (steps 1-3)

1: Siphon block

2: Screw plug

The VISATRON® VN2020 oil mist detector is now ready for operation!

7 Manufacturer settings

7.1 Parameter settings, VISATRON® VN2020/VN2020 EX

The VISATRON® VN2020/ VN2020 EX oil mist detector has two available alarm thresholds.

The main alarm threshold can be changed using the software and the interface (USB port) on the measuring head, as shown in the figure below. The pre-alarm can also be adjusted.

Using the factory setting, it is activated at 70% of the main alarm threshold.

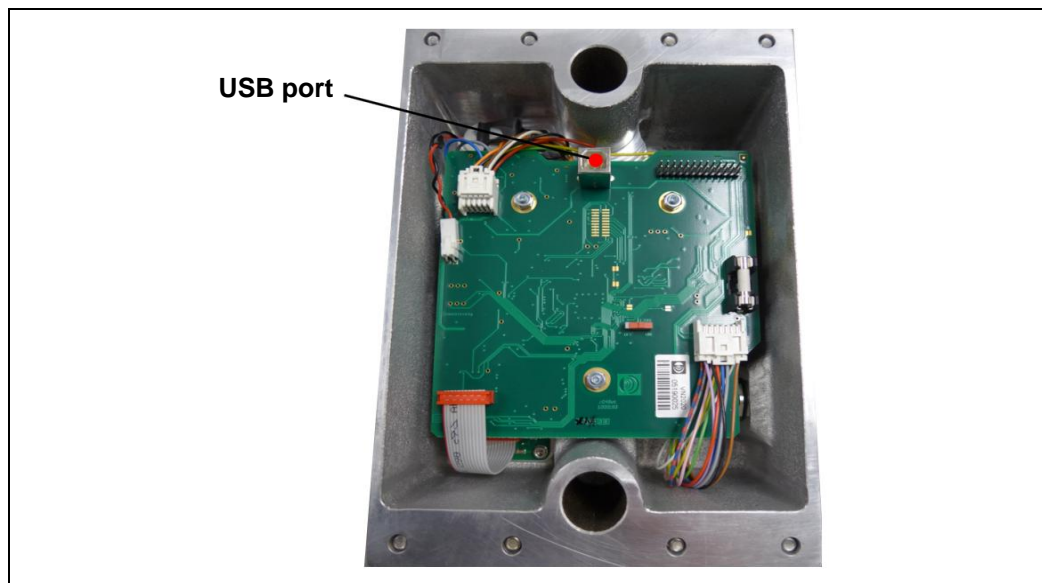

Fig.: 65 : Measuring head for VN2020, rear view, USB port



CAUTION



Adjusting the parameters of the measuring head safely and correctly

- ▶ To adjust the parameters of the measuring head, read the latest version of the operating manual or the user manual for the VN2020 end-user software (Part number 180115). Please also comply with the other documents accompanying the product, read them carefully and keep them in a suitable place for future reference.



NOTE



Personal protective equipment

Operating the device or working on the device without protective equipment may result in serious injury. For the workplace PPE, the following protective equipment must be used:

- ▶ Safety glasses in accordance with DIN EN 166 or DIN EN 170.
- ▶ Safety helmet in accordance with DIN EN 397 or DIN EN 50365.
- ▶ ESD safety shoes according to ESD standard DIN EN 61340-5-1.





⚠

DANGER



- ▶ You may only adjust the parameters of the measuring head with the engine switched off. The power and compressed air supply to the oil mist detector must also be switched off first.
- ▶ Before starting to adjust parameters, the housing of the VISATRON® VN2020/VN2020 EX oil mist detector must be earthed. → Section 6.4.5 Connecting housing earth to the protective cover of the VN2020

The following components are required for adjusting the parameters:

- Service laptop/netbook (provided by the user)
 - ▶ The minimum system requirements are described in detail in the “User manual for VN2020 end-user software (part number 180115)” under System Requirements.
- USB A/B connection cable -> connector **A** to connector **B** (provided by the user)
- Service software, for adjusting the parameters (included in the delivery)
 - ▶ The service software must be installed on the laptop first, as per the above manual.
 - ▶ Also see the manual for how to use the software.

To access the USB port on the measuring head, it has to be removed first from the base plate of the VN2020 as follows and then turned onto the back of the housing. Please note that the seal on the measuring head must be replaced each time it is refitted! Please read the instructions and information in Section 9.3.1. → Section 9.3.1 Replacing the VN2020/VN2020 EX measuring head

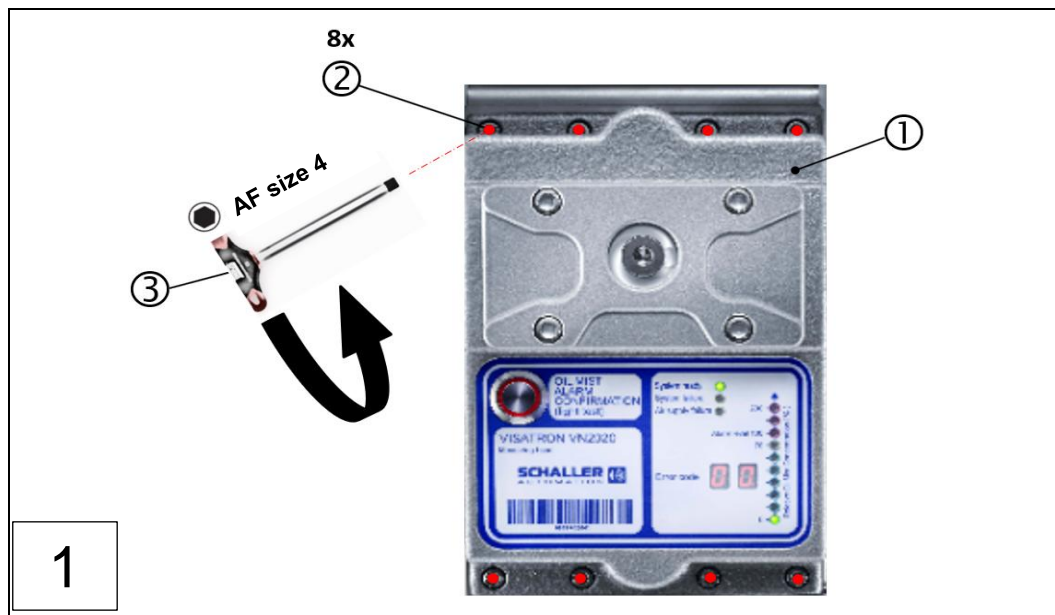

1: VN2020 measuring head
3: Allen key, size 4

2: 8x neck collar bolts

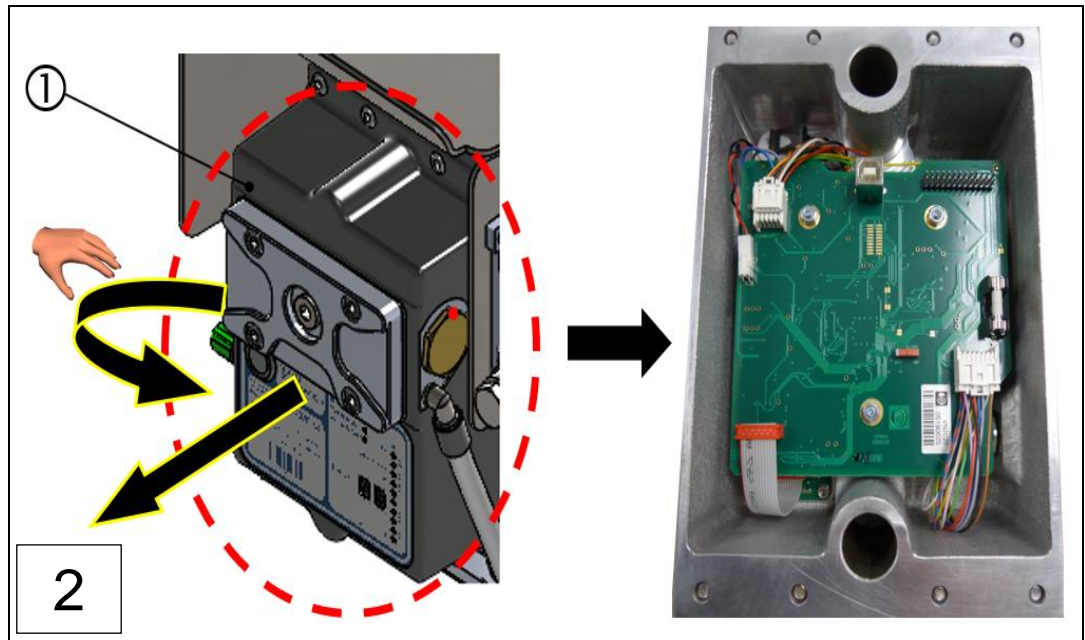

Fig.: 66 : Removing the VN2020 measuring head (installation steps 1-2)

1: VN2020 measuring head

The laptop and the measuring head are connected as shown in the figure below:

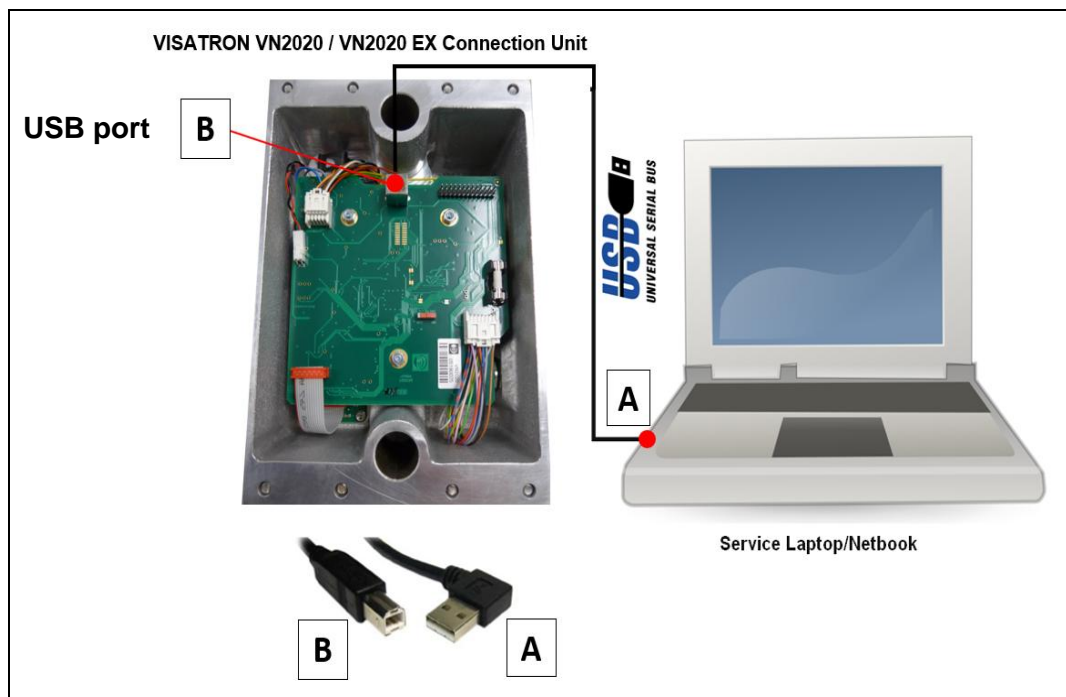

Fig.: 67 : Establishing the USB connection between the VN2020 measuring head and PC

NOTE



Adjusting the parameters of the VISATRON® VN2020 measuring head

- ▶ When adjusting the parameters, only the parameters of the connected measuring head are adjusted.
- ▶ Sensitivity level 2 is the factory setting.

The parameters are entered as per the parameter list below:

Parameter set	Input values 1	Input values 2
Number of suction points (compartments)	5 to 10	
Pre-alarm threshold	20% to 100%	
Oil mist alarm threshold	Oil mist concentration	Opacity alarm threshold
1	0.55 mg/l	1.50%
2 (Default factory setting)	0.70 mg/l	2.00%
3	0.90 mg/l	2.50%
4	1.10 mg/l	3.00%
5	1.40 mg/l	4.00%
6	1.80 mg/l	5.00%
7	2.50 mg/l	7.00%
Date	Automatically entered by the system	
Time	Automatically entered by the system	

Table 13 : Parameter list

Once changing the parameters has been completed successfully, carry out installation steps 1-2 in reverse order.

- ▶ Please note that the seal on the measuring head must be replaced each time it is refitted!

Then fasten the neck collar bolts (②) as shown in the figure below, observing the fastening sequence ① to ⑧ and the defined tightening torque!

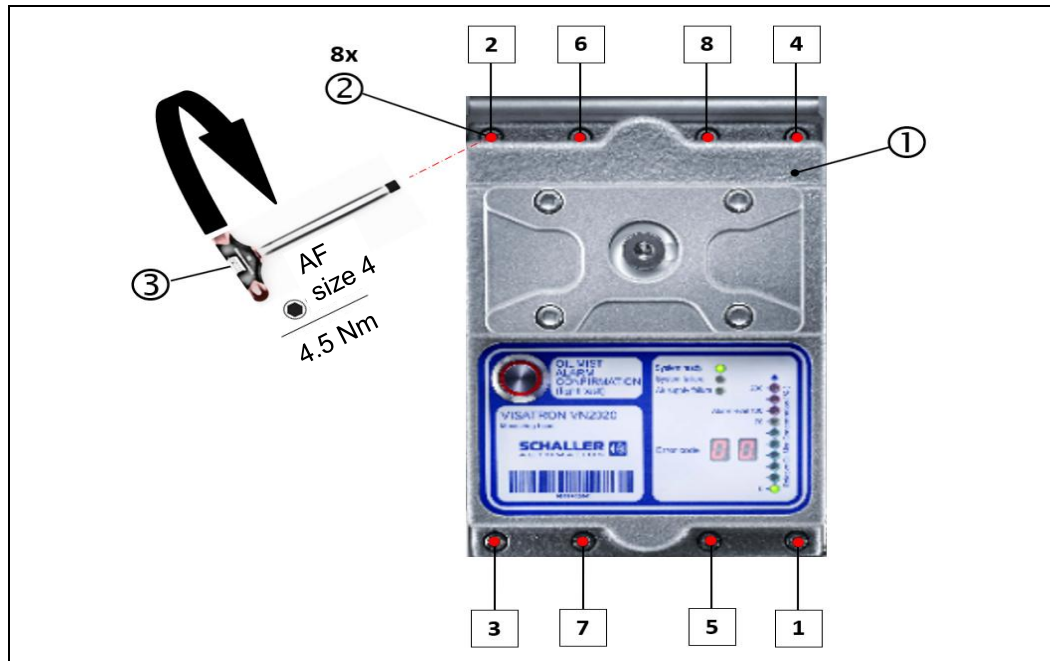

Fig.: 68 : Installing the VN2020 measuring head

- 1: VN2020 measuring head
- 2: 8x neck collar bolts
- 3: Allen key, size 4

Finally, re-establish all electrical and pneumatic connections to the measuring head.

- Adjusting the parameters of the VISATRON® VN2020 measuring head has been completed successfully!**

8 Operation and use

This section describes how to operate the product. This section covers all the operating modes available on the product, as well as how to restart the product after a system failure, and also warns of hazardous situations that may arise during operation.



 WARNING	
<p>Risk of oil mist explosion</p> <p>Failure to comply with the safety instructions may result in major damage to property or the environment and in serious injury or death.</p> <ul style="list-style-type: none"> ▶ Safe operation is conditional on no explosive atmosphere escaping into the engine room. An explosive atmosphere that escapes can cause an explosion. ▶ Start by familiarising yourself with the basic safety instructions for working with the oil mist detector. ⇒ <i>Section 2.4 Basic safety instructions</i> ▶ If the oil mist detector is operated in explosion-proof areas, the relevant safety instructions must be observed. ⇒ <i>Section 2.4.1 Safety instructions for potentially explosive atmospheres</i> 	



 CAUTION	
<p>Safe and proper use of the device</p> <ul style="list-style-type: none"> ▶ Read this operating manual, the user manual for the end-user software and the other documents that accompany the product carefully and keep them in a suitable place for future reference. 	



NOTE	
<p>Personal protective equipment</p> <p>Operating the device or working on the device <u>without</u> protective equipment may result in serious injury. For the workplace PPE, the following protective equipment must be used:</p> <ul style="list-style-type: none"> ▶ DIN EN 388:2016 Protective gloves against mechanical risks, 2341X, and DIN EN 407:2004 Protective gloves against thermal risks, X1XXXX. ▶ Safety glasses in accordance with DIN EN 166 or DIN EN 170. ▶ Safety helmet in accordance with DIN EN 397 or DIN EN 50365. ▶ ESD safety shoes according to ESD standard DIN EN 61340-5-1. 	

8.1 Check every time before operation

The oil mist detector must be checked according to the checklist in Section 6.5.1 every time before it is started up. ⇒ *Section 6.5.1 Checklist for starting up for the first time*

If the checklist has open points after the check, you must work through all of Sections 6.5.2 to 6.5.5 again.

⇒ *Section 6.5.2 Connecting the power supply*

⇒ *Section 6.5.3 Setting the negative pressure at the measuring head of the VN2020/VN2020 EX*

⇒ *Section 6.5.4 Setting the sensitivity on the VN2020/VN2020 EX oil mist detector*

⇒ *Section 6.5.5 Function test when starting up for the first time*

- The oil mist detector is functioning and ready for operation when the checklist has been completed successfully.**

For further information, please see Section 10 of this manual. → Section 10 Error diagnosis and troubleshooting

8.2 Operation under correct conditions

The operating temperature for the VN2020 EX $\text{CE 0637 Ex II (2G) [Ex op is IIB T4 Gb]}$ is:

- System operating temperature: +5 °C to +70 °C**

The conditions in Section 3.4.4 must also be observed for safe and correct operation!
→ Section 3.4.4 Environmental conditions

8.3 Switching the device on and off

The oil mist detector is switched on and off by switching on and off the power supply, which is provided by the operator. The other steps for starting up are described in detail in Section 6.5.2.

→ Section 6.5.2 Connecting the power supply

- The oil mist detector is switched on and ready for operation!**

8.4 Normal operation

The figure below shows the display of the VISATRON® VN2020/VN2020 EX in normal operation:

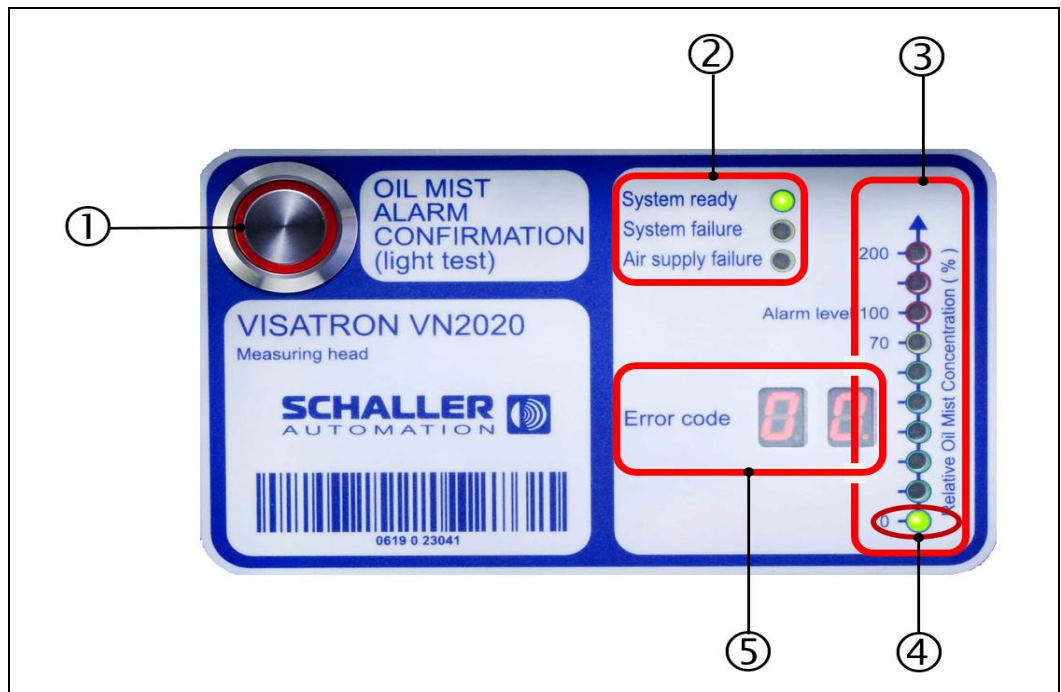

Fig.: 69 : VN2020 measuring head: Display in normal operation

- | | |
|---|------------------------|
| 1: Confirmation button | 2: System status |
| 3: Display; relative oil mist concentration | 4: LED display, OMC 0% |
| 5: Display, error code | |

The VISATRON® VN2020/VN2020 EX oil mist detector is ready for operation, indicated by the green “System ready” LED (②). The LED around the (①) button is switched off in this mode of operation.

The relative oil mist concentration (OMC) (③) is displayed on the LED level indicator on the right. In the example shown, there is no oil mist and the system is therefore in normal operation or at an OMC of 0% (④); the LED is green.

In normal operation, the display shows “Error Code” (⑤) 00. This means that there are no device or system errors.

The oil mist detector is in normal operation and is ready for operation!

8.5 LED check

An LED check can be run for the VISATRON® VN2020/VN2020 EX oil mist detector at any time to check that it is functioning and to check the display.



NOTE

Exception for the LED check

- ▶ The light test can only be carried out when there is no oil mist alarm!

The LED check is carried out as follows:



Fig.: 70 : VN2020 measuring head: LED check (light test)

1: Confirmation button

1. Press the (①) button on the measuring head display.
 - ▶ Then all the LEDs come on as a test and flash for 2 seconds. The previous status is then displayed again.
 - ▶ If there is an oil mist alarm, this button confirms the alarm.

The LED check has been completed successfully!

8.6 Checking the supply pressure, sensor OMC and sensitivity

To carry out these checks, please see the following sections in this manual:

- ⇒ Section 6.5.3 Setting the negative pressure at the measuring head of the VN2020/VN2020 EX
- ⇒ Section 6.5.4 Setting the sensitivity on the VN2020/VN2020 EX oil mist detector

The sensitivity check and supply pressure check have been completed successfully!

8.7 “Oil mist pre-alarm” status indicator

When high relative oil mist concentrations are reached, the LED bar display (②) comes on or the LED display increases steadily.

Example use case:

At a relative oil mist concentration of 70%, the pre-alarm relay is activated and the pre-alarm is triggered. As shown in the figure below, the “Oil Mist Alarm” LED (①) comes on **red** and the “70” LED (②) on the bar display comes on **orange**.

The “System ready” LED (③) stays **green**.

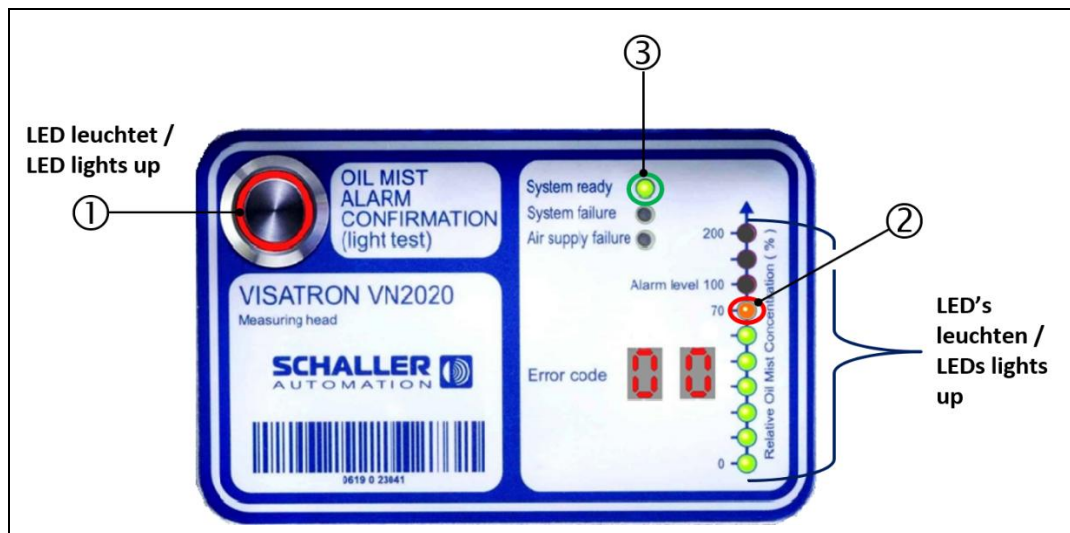

Fig.: 71 : VN2020 measuring head: “Pre-alarm” status indicator at 70% OMC

- 1: Confirmation button
- 2: Display; relative oil mist concentration
- 3: System status

8.8 “Oil mist alarm” status indicator

DANGER

Risk of death

There is a risk of serious injury, including death, due to explosion in the crankcase as a result of incorrect installation.

- ▶ In the event of an oil mist alarm, do not approach the engine again until the alarm threshold on the oil mist detector or the remote indicator has fallen again.



- ▶ The manufacturer recommends that only approach the engine again when the alarm threshold has dropped to 0% relative oil mist concentration.
- ▶ If a Remote Indicator II is used for remote monitoring, it must be used to continuously check the current oil mist concentration.
- ▶ Familiarise yourself with the basic safety instructions before starting to operate the device. → Section 2.4 Basic safety instructions
- ▶ If the oil mist detector is operated in explosion-proof areas, the relevant safety instructions must be observed. → Section 2.4.1 Safety instructions for potentially explosive atmospheres

NOTE



- Action in the event of an oil mist alarm**
- ▶ The oil mist alarm message must be confirmed by pressing the oil mist alarm confirmation button on the measuring head of the VISATRON® VN2020.
 - ▶ The relative oil mist concentration (opacity) is displayed on the LED level display on the right.

In the event of damage to the main or big end bearing, it can be assumed that the relative oil mist concentration will reach the defined alarm threshold in a very short time.

Example use case:

- The oil mist alarm is triggered at a relative oil mist concentration $\geq 100\%$, as shown in the figure below. In this case, the “Alarm level 100” LED on the LED bar display (right) turns **red**. (②)
- At the same time, the “Oil Mist Alarm” LED (top left) starts to flash **red**. (①)
- The “System ready” LED (③) stays **green**.
- If the opacity subsequently decreases, the alarm status is saved.

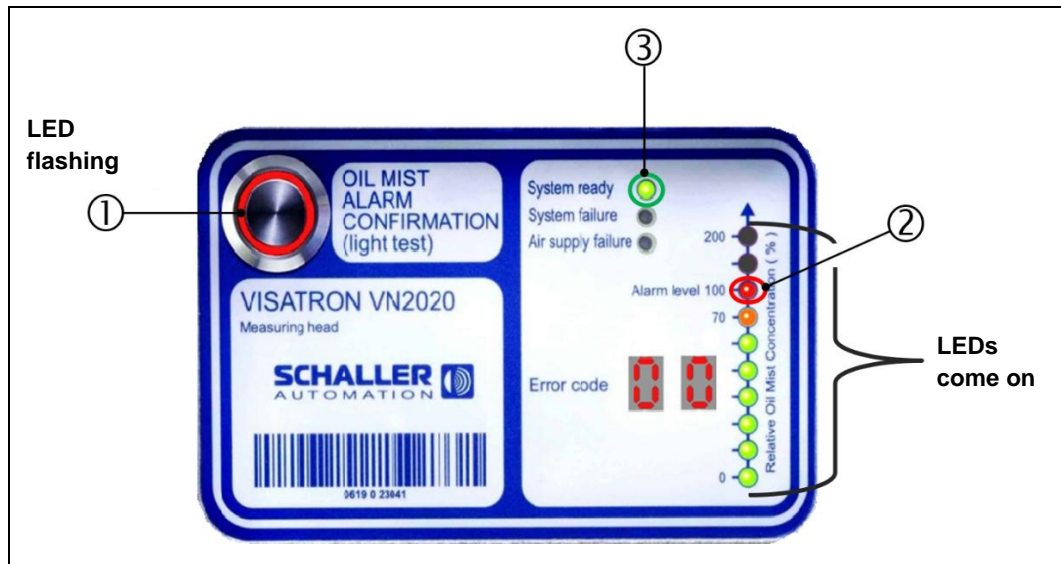

Fig.: 72 : VN2020 measuring head: “Alarm” status indicator at 100% OMC

- 1: Confirmation button
- 2: Display; relative oil mist concentration
- 3: System status

8.9 Confirming an oil mist alarm



DANGER

Risk of death

There is a risk of serious injury, including death, due to explosion in the crankcase as a result of incorrect installation.

- ▶ In the event of an oil mist alarm, do not approach the engine again until the alarm threshold has dropped to at least < 50% relative oil mist concentration.
- ▶ The manufacturer recommends that only approach the engine again when the alarm threshold has dropped to 0% relative oil mist concentration.
- ▶ If a Remote Indicator II is used for remote monitoring, it must be used to continuously check the current oil mist concentration.
- ▶ Familiarise yourself with the basic safety instructions before starting to operate the device. → Section 2.4 Basic safety instructions
- ▶ If the oil mist detector is operated in explosion-proof areas, the relevant safety instructions must be observed. → Section 2.4.1 Safety instructions for potentially explosive atmospheres



CAUTION

Confirming an oil mist alarm

- ▶ Only confirm the oil mist alarm using the confirmation button if you have previously made sure that there are no more high oil mist concentrations in the crankcase, or as soon as the concentration is below the alarm limit displayed (<70%).

1. The oil mist alarm message must be confirmed by pressing the button (①) on the VISATRON® VN2020 measuring head.



Fig.: 73 : VN2020 measuring head: Confirming an oil mist alarm

1: Confirmation button

9 Maintenance and repair



WARNING

Warning – risk of oil mist explosion during maintenance work

- ▶ Safe operation is conditional on no explosive atmosphere escaping into the engine room. An explosive atmosphere that escapes can cause a risk of explosion.
- ▶ Only carry out maintenance and repair work when the engine is stopped.
- ▶ The power and compressed air supply must be switched off before starting maintenance and repair work.
- ▶ Do not mix up any components from the standard version (VISATRON® VN2020) with the Ex version (VN2020^{EX}).
- ▶ The oil mist detector must not be cleaned with a steam cleaner, high pressure cleaner or similar device.
- ▶ Also familiarise yourself with the basic safety instructions for working with the oil mist detector. → *Section 2.4 Basic safety instructions*
- ▶ If the oil mist detector is operated in explosion-proof areas, the relevant safety instructions must be observed. → *Section 2.4.1 Safety instructions for potentially explosive atmospheres*



CAUTION

Safe and correct maintenance of the device

- ▶ Read this operating manual and other documents that accompany the product carefully first and keep them in a suitable place for future reference.



NOTE

Personal protective equipment

Operating the device or working on the device without protective equipment may result in serious injury. For the workplace PPE, the following protective equipment must be used:

- ▶ DIN EN 388:2016 Protective gloves against mechanical risks, 2341X, and DIN EN 407:2004 Protective gloves against thermal risks, X1XXXX.
- ▶ Safety glasses in accordance with DIN EN 166 or DIN EN 170.
- ▶ Safety helmet in accordance with DIN EN 397 or DIN EN 50365.
- ▶ ESD safety shoes according to ESD standard DIN EN 61340-5-1.

9.1 Maintenance by the operator

Maintenance is intended maintain the device in a condition ready for operation and to prevent premature wear. Maintenance is divided into:

- Cleaning and care
- Maintenance/inspection
- Repair

To ensure that the device is in proper working condition, the operating personnel must:

- regularly check that the required safety equipment are functioning correctly;
- ensure that the safety equipment is effective; and
- carry out recurring inspections.
 - ▶ Follow the intervals and instructions for inspection and maintenance for the supplied parts.
 - ▶ Keep and archive a record of inspection.
 - ▶ Report identified safety defects to the plant operator.
 - ▶ Carry out the maintenance work according to the following maintenance table at the specified maintenance intervals.

**WARNING**

Risk of serious injury or death from oil mist explosion during maintenance work

- ▶ Only use original spare parts from Schaller Automation for maintenance and repair work!



All the maintenance work is described in the following sections.

9.1.1 Maintenance cycles for reliable operation

The table below lists the maintenance cycles for the VISATRON® VN2020 and VN2020 EX oil mist detector.

If the maintenance intervals are not observed, the oil mist detector may fail early.

It is essential that you follow the given sequence for the work.

No./action	Description	Interval every six months or after every 4,000 operating hours (whichever occurs first)					
		4,000	8,000	12,000	16,000	See Section	Required parts/tools
		Or months	6	12	18		
1.	Check the supply pressure setting at the measuring head: <ul style="list-style-type: none"> ▪ Negative pressure < 55 mmWC (5.5 mbar) → Adjust negative pressure ▪ Negative pressure between 55 mmWC and 65 mmWC → OK ▪ Negative pressure above 85 mmWC → Adjust negative pressure 	X	X	X	X	6.5.3	U-tube manometer (270532) or Digital manometer (151800)
2.	Clean the light path in the measuring head	X	X	X	X	9.1.2	Cleaning kit (151482)
3.	Function test using smoke tube (mist test)	X	X	X	X	9.1.4	Smoke Test Box (151780)
4.	Replace the air filter in the pressure regulator unit	X	X	X	X	9.1.3	Maintenance kit VN2020 (155006)
5.	Replace inspection cover seal	X	X	X	X	9.3.3	Maintenance kit VN2020 (155006/155004)

6.	Replace connecting box seal		X		X	9.1.5	Maintenance kit VN2020 (155006)
7.	Clean the intake system with compressed air				S	-	Compressed air (max. 6 bar)
8.	Replacing the seal on the mounting plate		X		X	9.3.4	Maintenance kit VN2020 (155006)
9.	Check the bellows and spring systems between the base plate and the measuring head for damage → Damaged parts must be replaced immediately		X		X	*	May need a torch
10.	Complete overhaul of the oil mist detector, including the replacement of suspensions (spring systems) and bellows. → Device inspection (final check)				S	9.4	Service kit for the VN2020 (155004)
<p><u>Key to maintenance measures:</u></p> <p>X - Work that must be carried out by trained on-board personnel or by Schaller Service</p> <p>S – Work that must only be carried out by authorised and certified Schaller Service</p> <p>*) – If the bellows are damaged, please contact Schaller Service immediately.</p>							

Table 14 : Maintenance cycles

9.1.2 Cleaning the light path on the measuring head (4,000 hours)



NOTE

Cleaning and care of system components

For the cleaning and maintenance of system components of the VN2020 oil mist detector, the following **optional** products are offered by Schaller Automation as accessories and can be ordered directly under the listed part numbers:

- ▶ Cleaning kit including cleaning fluid (151482)
- ▶ Maintenance kit VN2020 (155006)



CAUTION

Safe and correct maintenance of the device

- ▶ When you open the inspection cover, a new seal must always be inserted. Only use the seal from the above VN2020 maintenance kit.



Any required cleaning of the light path section is indicated by the “System ready” LED (①) going off and the “System failure” LED (②, red) coming on, in combination with “Error code 15” (③) being displayed on the measuring head of the VISATRON® VN2020/VN2020 EX, as shown in the figure below.

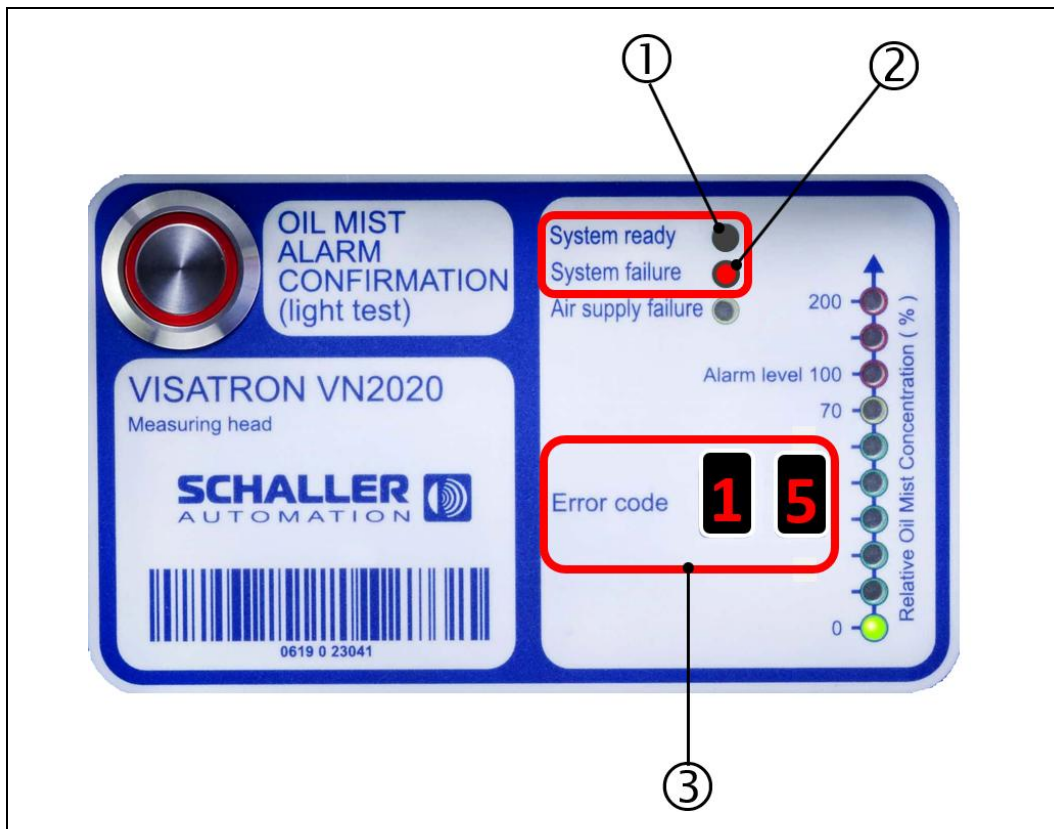

Fig.: 74 : “Sensor cleaning” status display, VN2020

- 1: “System ready” LED
- 3: “Error code” display

- 2: “System failure” LED



WARNING

Warning – risk of oil mist explosion during maintenance work

- ▶ Safe operation is conditional on no explosive atmosphere escaping into the engine room. An explosive atmosphere that escapes can cause a risk of explosion.
- ▶ Only carry out maintenance and repair work when the engine is stopped.
- ▶ The power and compressed air supply must be switched off before starting maintenance and repair work.
- ▶ Also familiarise yourself with the basic safety instructions for working with the oil mist detector. → Section 2.4 Basic safety instructions
- ▶ If the oil mist detector is operated in explosion-proof areas, the relevant safety instructions must be observed. → Section 2.4.1 Safety instructions for potentially explosive atmospheres

The measuring track area on the sensor unit is cleaned completely as follows:

- Remove the inspection cover on the measuring head
- Remove and dispose of the seal between the inspection cover and the measuring head
- Clean the diode glass, left/right
- Clean the sealing surface of the “inspection cover”
- Position and fit the new seal on the cleaned sealing surface
- Fit the inspection cover on the seal and then secure it in place

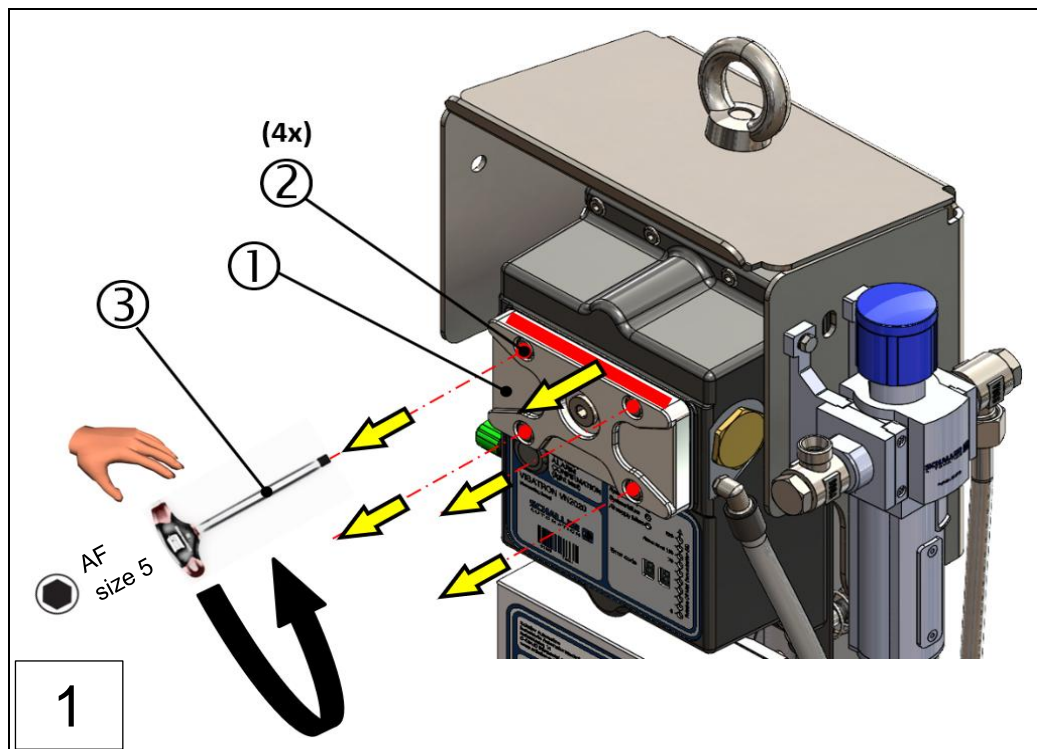

1: Inspection cover

2: 4x neck collar bolts

3: Allen torque spanner, size 5

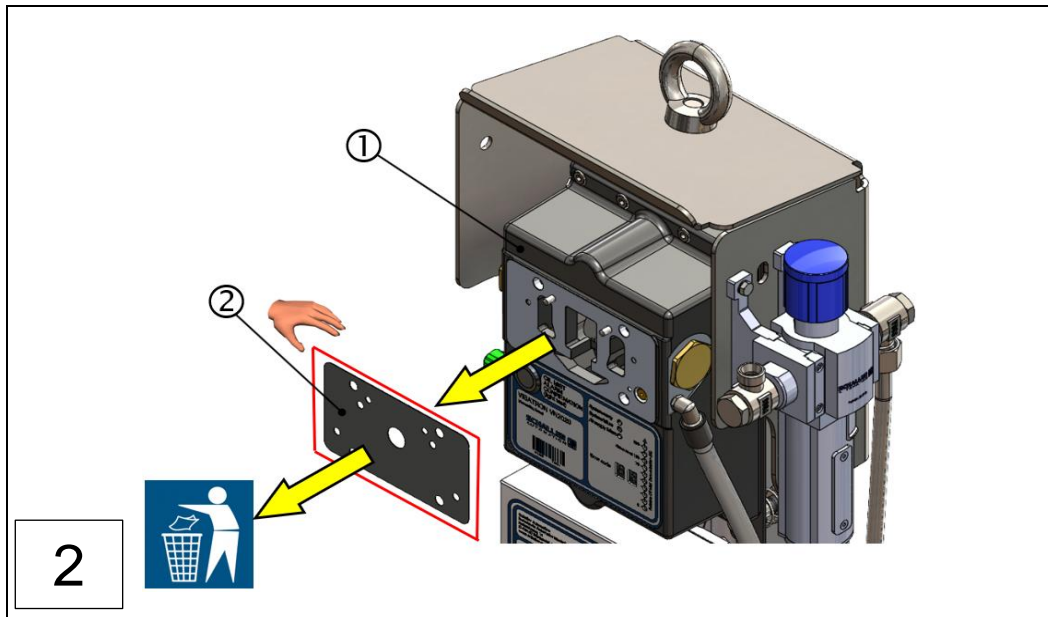

1: Measuring head

2: Seal (old -> dispose of!)

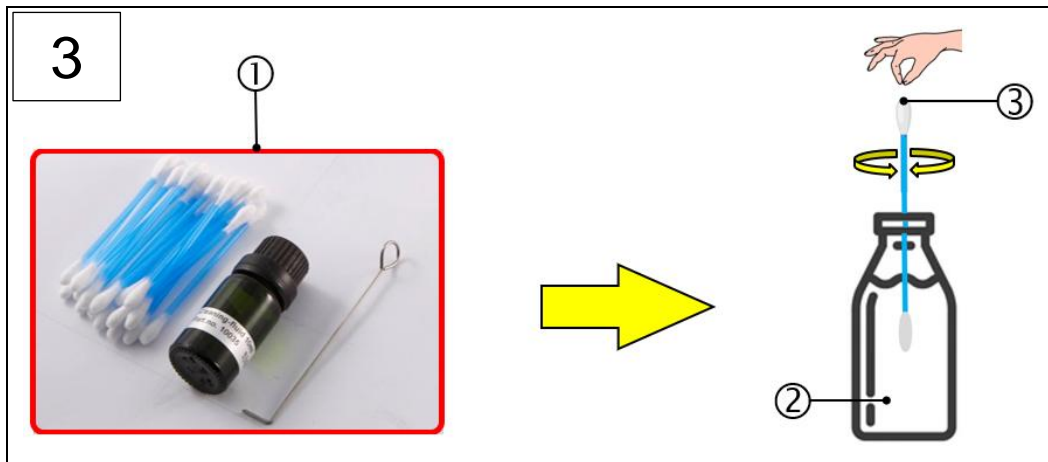

1: Schaller Cleaning Kit (151482)

2: Cleaning fluid

3: Cleaning buds from the cleaning kit

4: Diode glass, left

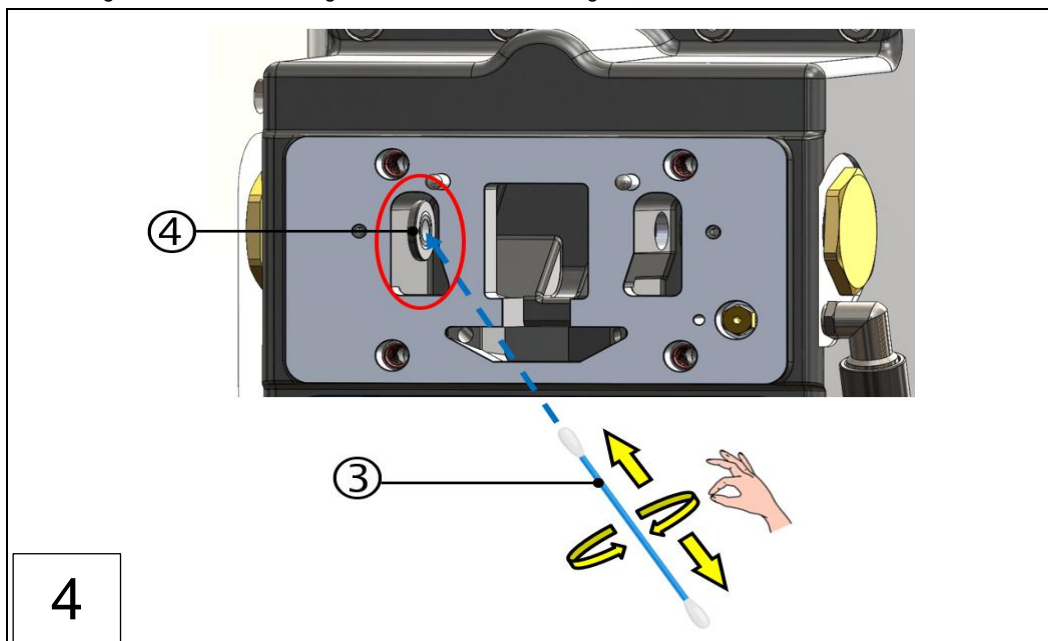

4



NOTE

Cleaning and care using the cleaning kit

- ▶ The cleaning buds from the cleaning kit are for single use only!
- ▶ The diode glass surfaces are cleaned with circular movements, as shown in the figure above.
- ▶ The power and compressed air supply must be switched off before starting maintenance and repair work.

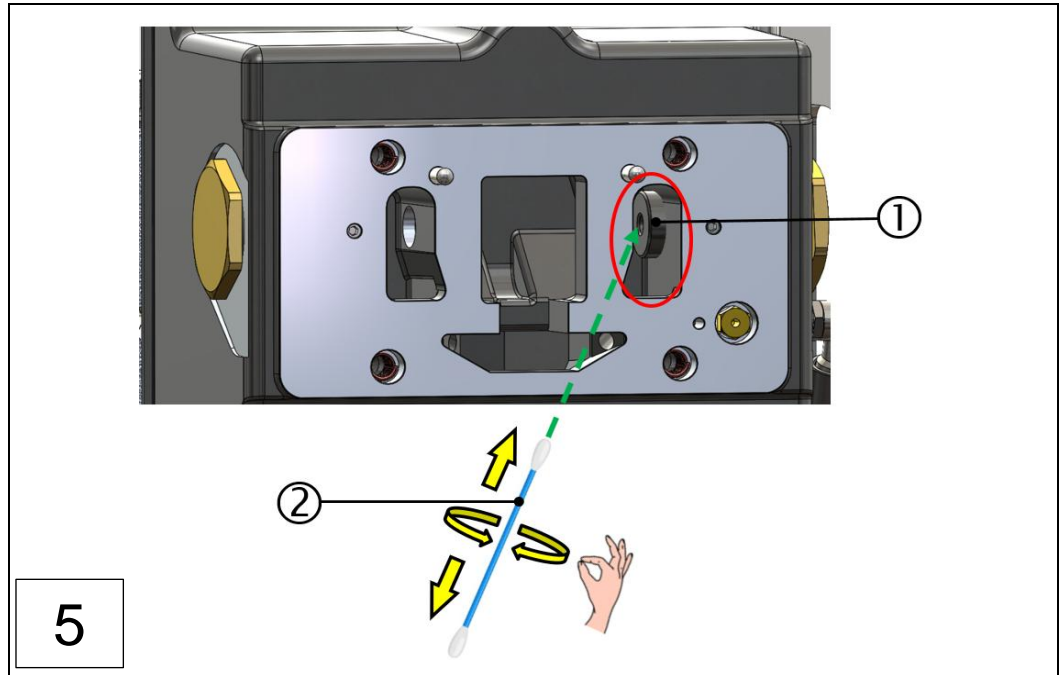

1: Diode glass, right

2: Cleaning buds from the cleaning kit

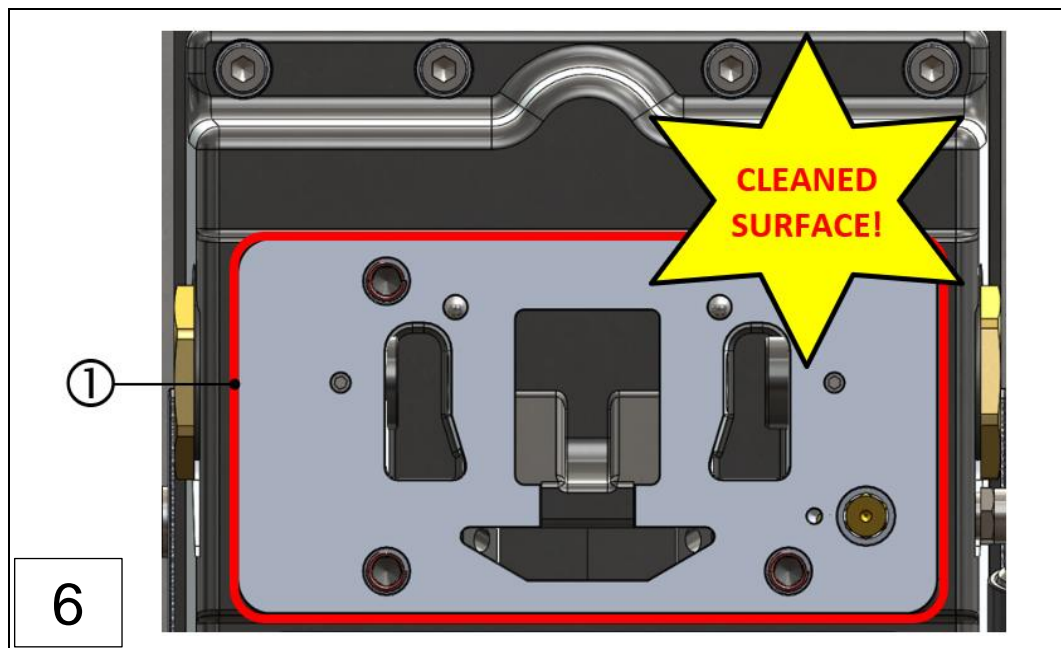

1: Sealing surface (cleaned) of inspection cover

- Cleaning the sealing surface (①) for the new seal of the inspection cover completed successfully.

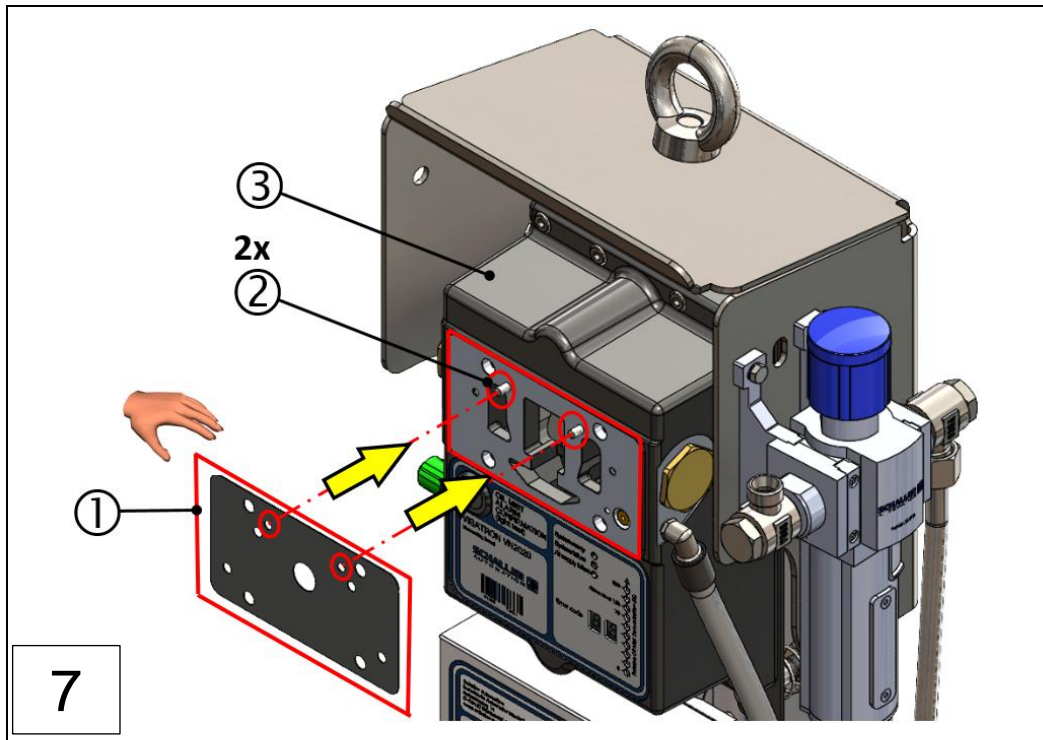

1: Seal (new)

2: 2x centring pins

3: Measuring head

- Positioning the **new seal** (1) for the inspection cover over the two dowel pins (2) completed successfully.

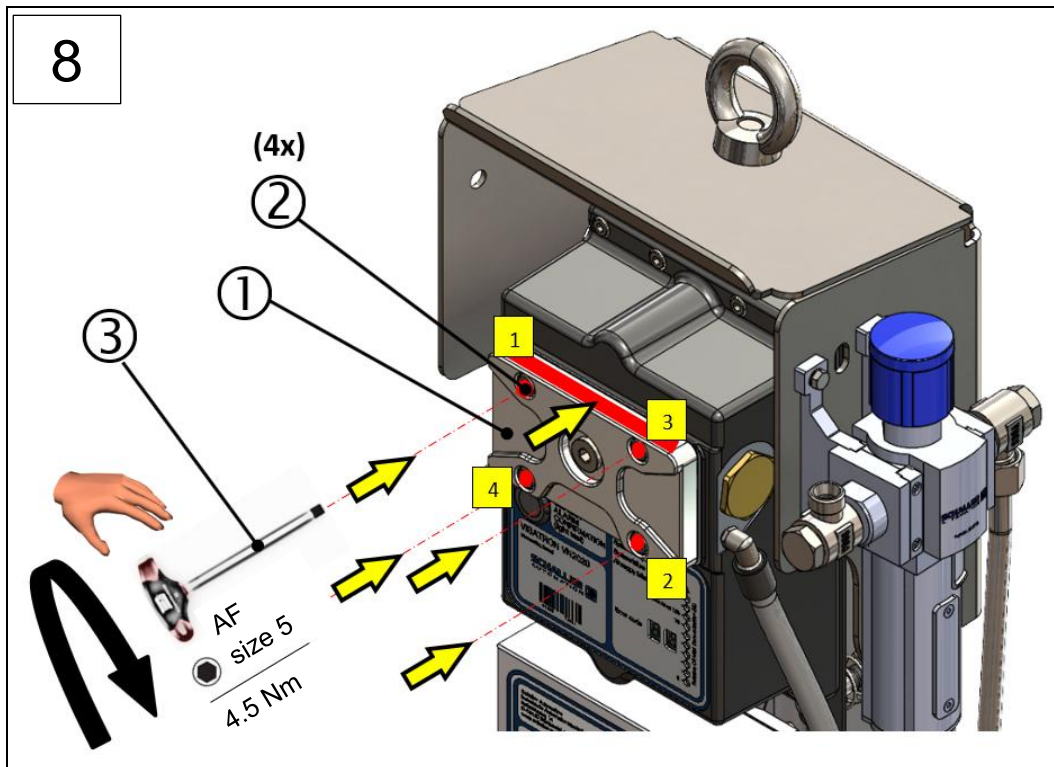

Fig.: 75 : Cleaning the light path of the VN2020 (steps 1-8)

1: Inspection cover

2: 4x neck collar bolts (tighten crosswise; sequence: 1-4)

3: Allen torque spanner, size 5

- ☑ The inspection cover (①) is positioned on the **new seal**
- ☑ The neck collar bolts (②) have been tightened crosswise (sequence: 1-4) using a torque spanner (③) to torque of 4.5 Nm.
- ☑ **The device is ready for operation!**

9.1.3 Replacing the air filter element on the pressure reducer unit (4,000 hours)

To ensure reliable operation of the VN2020 oil mist detector, the air filter element in the pressure regulator unit has to be replaced every six months or after 4,000 operating hours at the latest. The air filter element (366717) is part of the Schaller maintenance kit (155003) and can also be ordered separately from Schaller Automation if required.

NOTE



Maintenance work on the oil mist detector

- ▶ Observe the safety instructions in Section 9 ⇒ *Section 9 Maintenance and repair*
- ▶ The power and compressed air supply must be switched off before starting maintenance and repair work.



DANGER



Risk of injury

- ▶ The power and compressed air supply must be switched off before starting maintenance and repair work.



Fig.: 76 : Pressure regulator unit, VN2020 oil mist detector

1: VN2020 measuring head

2: Pressure regulator unit

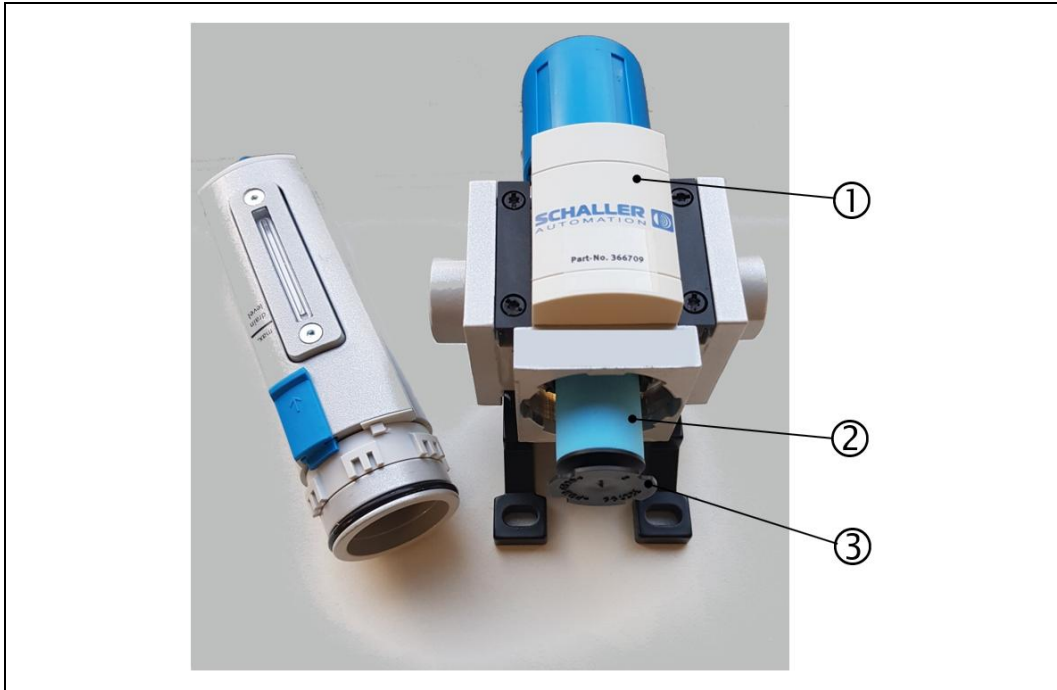
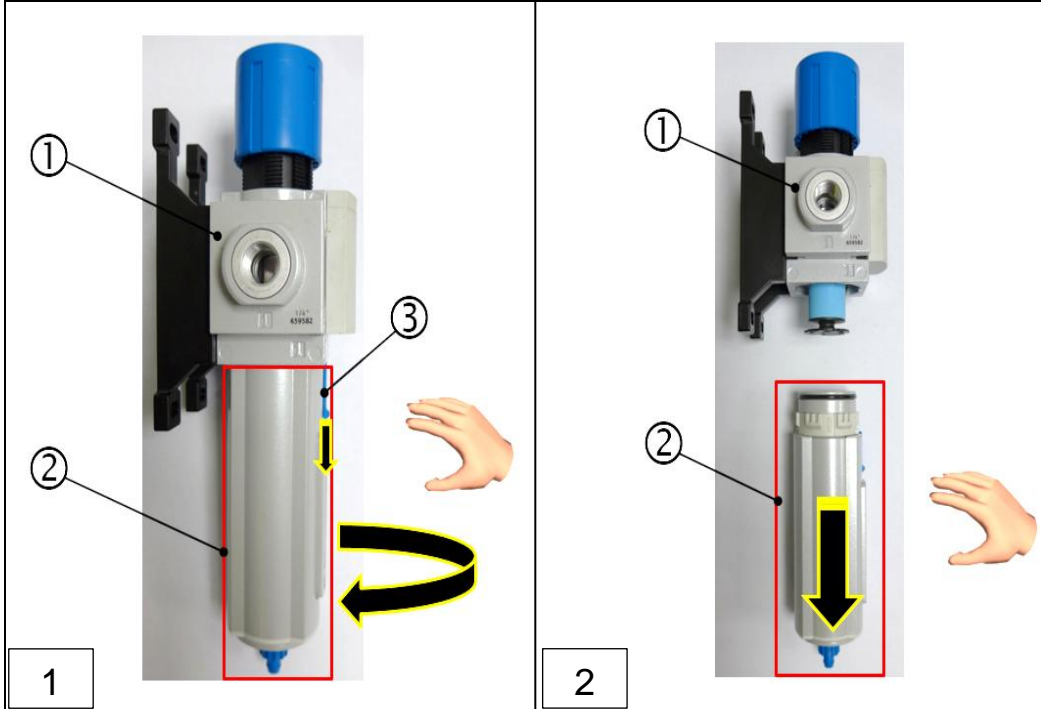

Fig.: 77 : Replacing the air filter element on the pressure regulator unit

- 1: Pressure regulator unit
- 2: Air filter element
- 3: Plastic disc

The air filter element is replaced according to the following steps:



- 1: Pressure regulator unit
- 2: Filter cover
- 3: Locking lever

- ▶ Note on steps 1 and 2: Start by pressing the locking lever (3) down and then unscrew the air filter cover (2). Then pull the air filter cover down.

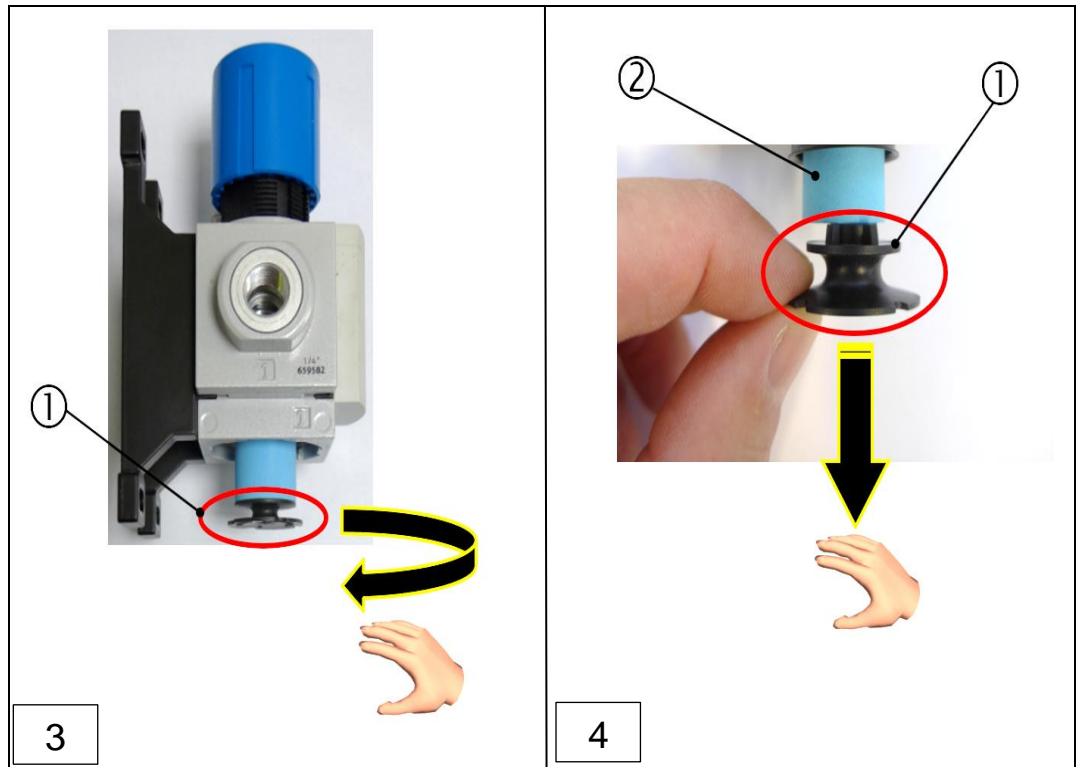

1: Plastic disc

2: "Old" air filter element

- ▶ Note on steps 3 and 4: Start by unscrewing the plastic disc (①) and then pull down the plastic disc (①) with the "old" air filter element (②).
- ▶ Note on step 5: Install the "new" air filter element (②) on the plastic disc.

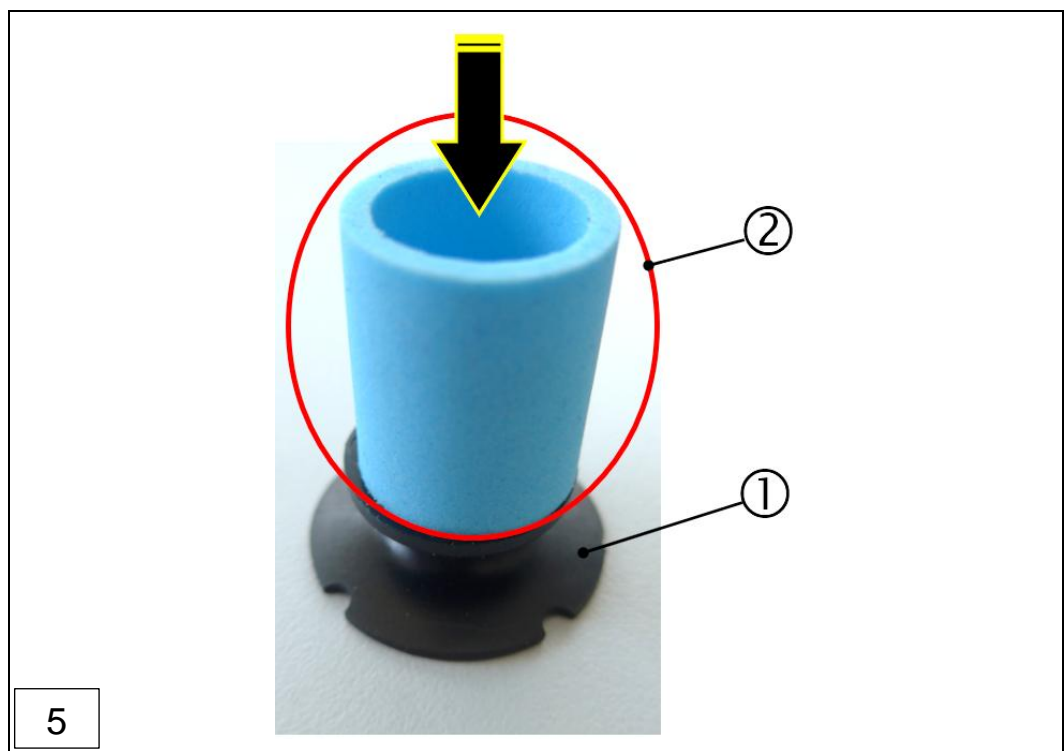

1: Plastic disc

2: "New" air filter element

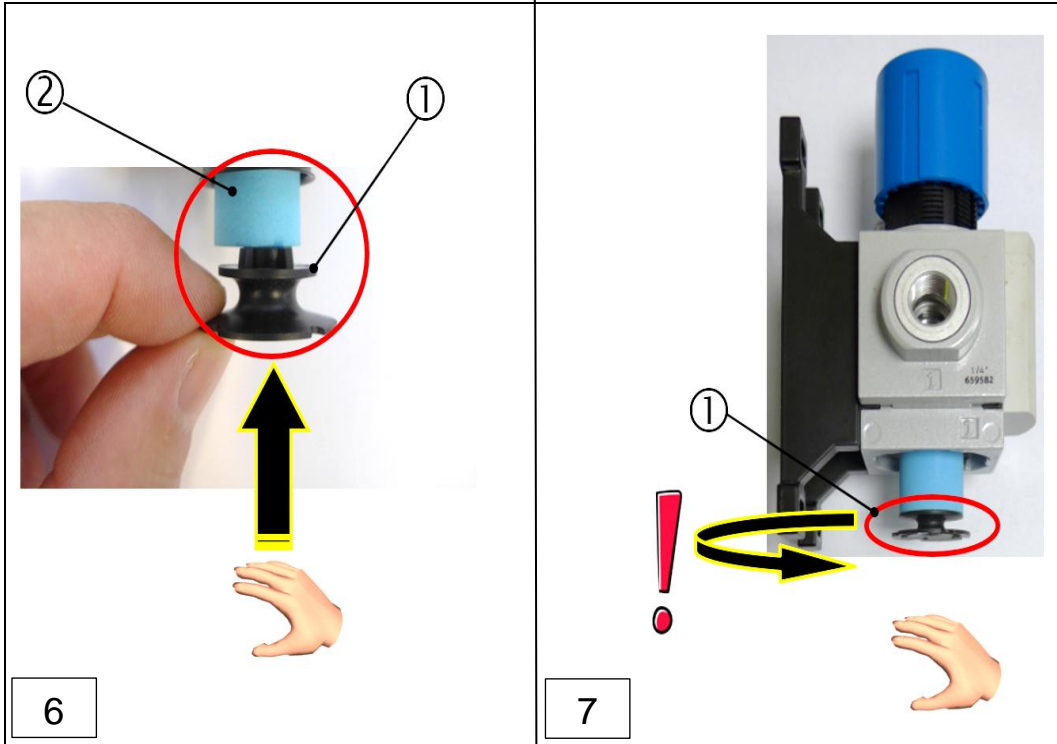

1: Plastic disc

2: "New" air filter element

- ▶ Note on step 6: Reinstall the plastic disc (①) with the "new" air filter element (②) into the pressure regulator unit.
- ▶ Note on step 7: Tighten the plastic disc (①) hand-tight.

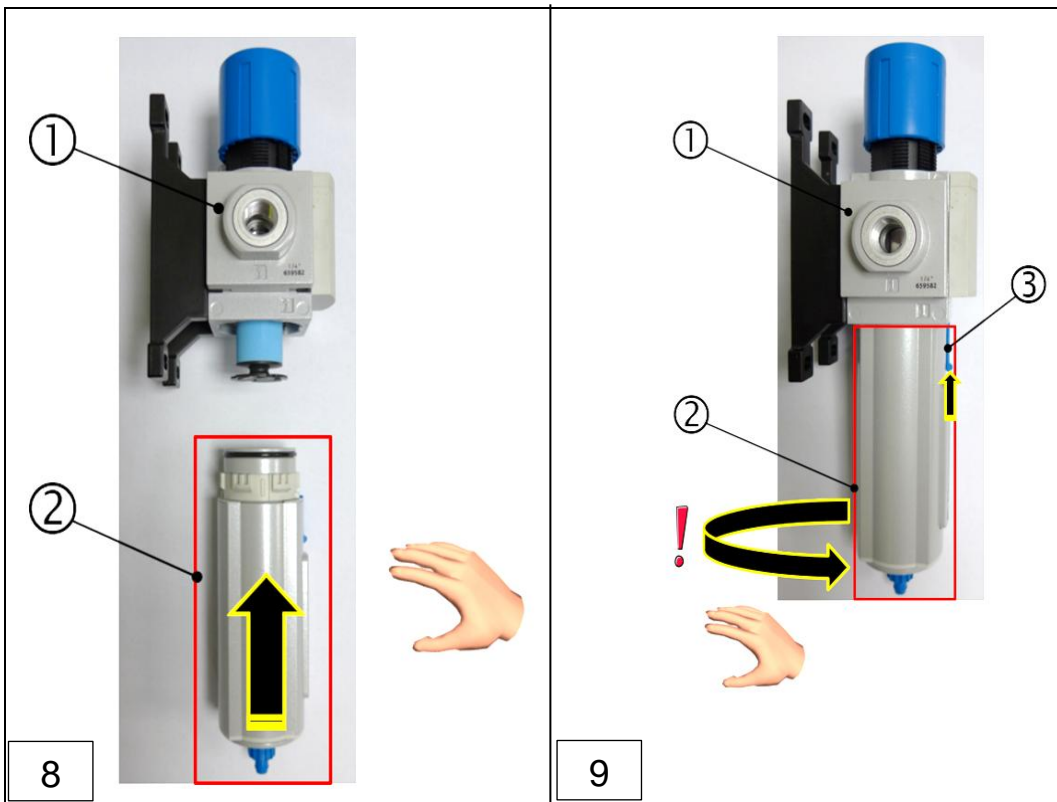

1: Pressure regulator unit
3: Locking lever

2: Filter cover

- ▶ Note on steps 8 and 9: Start by pushing the filter cover (②) into the pressure regulator unit (①) and then turn it to the right until the blue locking lever (③) engages automatically.

NOTE



Checking the supply pressure on the oil mist detector

- ▶ After completing installation step 9, the supply pressure on the VN2020 measuring head has to be checked again and readjusted if necessary.
- ▶ To carry out installation step 10, first see Section 6.5.3 ⇒ Section 6.5.3 Setting the negative pressure at the measuring head of the VN2020/VN2020 EX

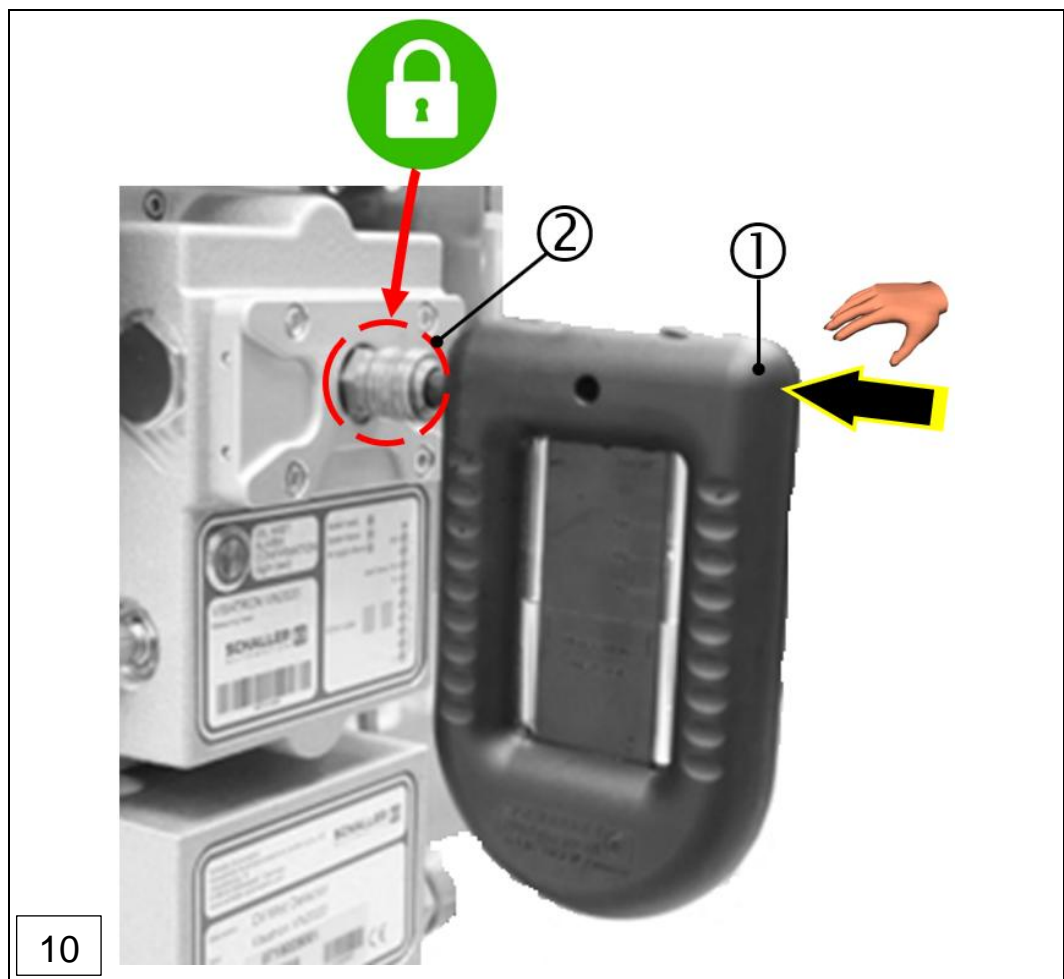

Fig.: 78 : Replacing the air filter element on the pressure regulator unit (steps 1-10)

1: U-tube manometer

2: Quick-release coupling

9.1.4 Function test of the oil mist detector using smoke tube (4,000 hours)

To ensure reliable operation of the VN2020/VN2020 EX oil mist detector, a function test with a smoke tube mist test must be carried out every six months or after 4,000 operating hours at the latest. To carry out the function test, you will need either the Tool Box VN301plus (151781) or the Smoke Test Box (151780).



WARNING

Engine is switched off

- ▶ Before a function test, the operator must make sure that the oil mist detector has been properly maintained first.
- ▶ For the function test, the safety instructions for handling the oil mist detector must be always observed. ⇒ Section 2.4 Basic safety instructions
- ▶ If the oil mist detector is operated in explosion-proof areas, the additional safety instructions must be observed. ⇒ Section 2.4.1 Safety instructions for potentially explosive atmospheres



NOTE

Assembling the smoke tube

- ▶ See the Smoke Test Box manual for how to assemble the smoke tube with the hand pump.

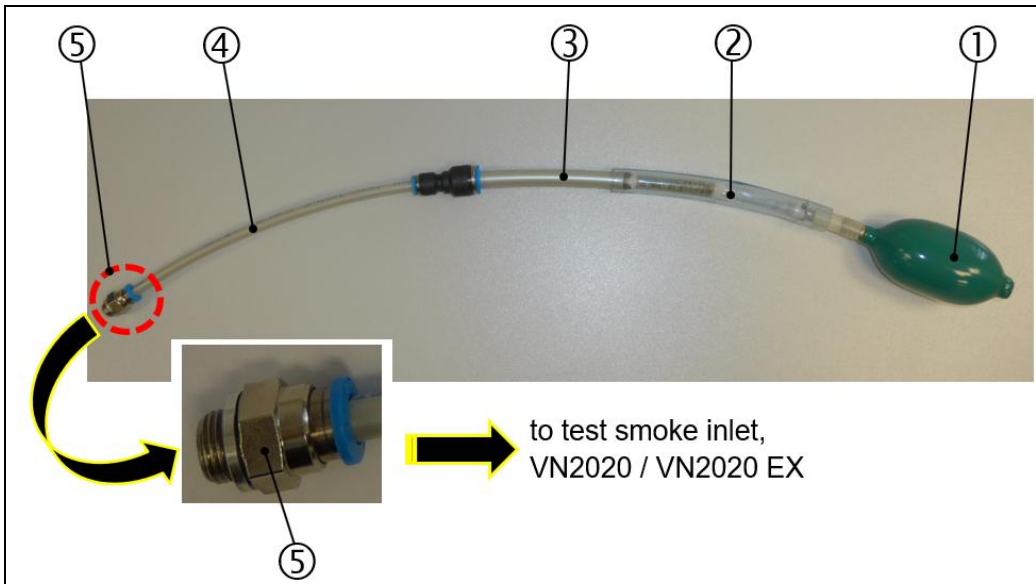
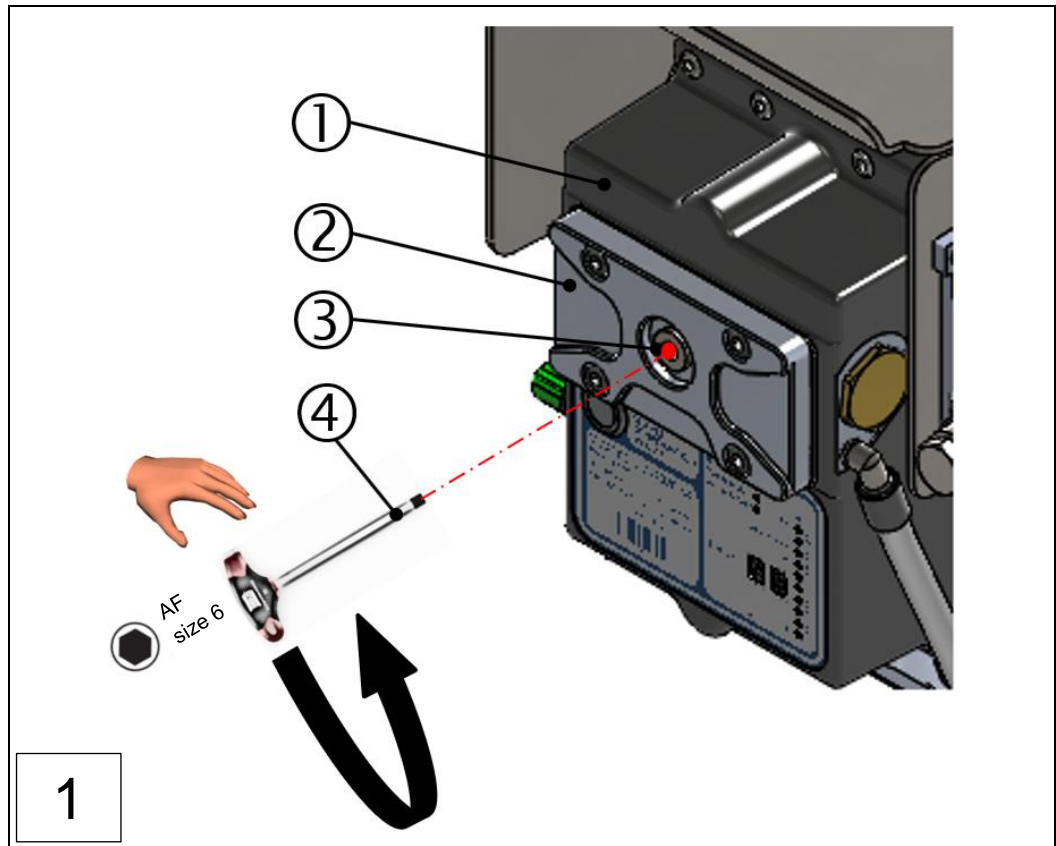

Fig.: 79 : Smoke tube with hand pump (assembled) from Smoke Test Box (151780)

- | | |
|--------------------|------------------|
| 1: Hand pump | 3: Adapter |
| 2: Smoke tube | 4: Flexible hose |
| 5: Push-in fitting | |

The function test is carried out according to the following steps:



1: Measuring head
2: Inspection cover
3: Screw plug
4: Allen key, size 6/torque spanner for 15 Nm

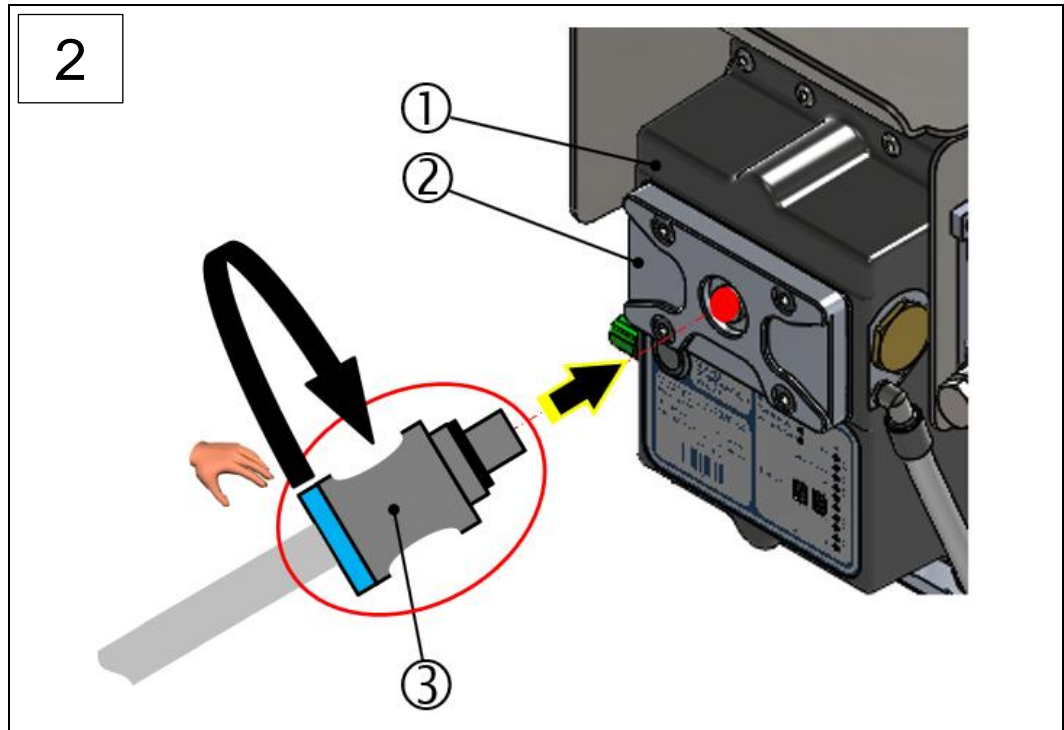

1: Measuring head
2: Inspection cover
3: Push-in fitting with flexible hose

- ▶ (3) is the same as 4 and 5 in Figure 79 in this section.
- ▶ (3) is screwed hand-tight into the inspection cover (2).

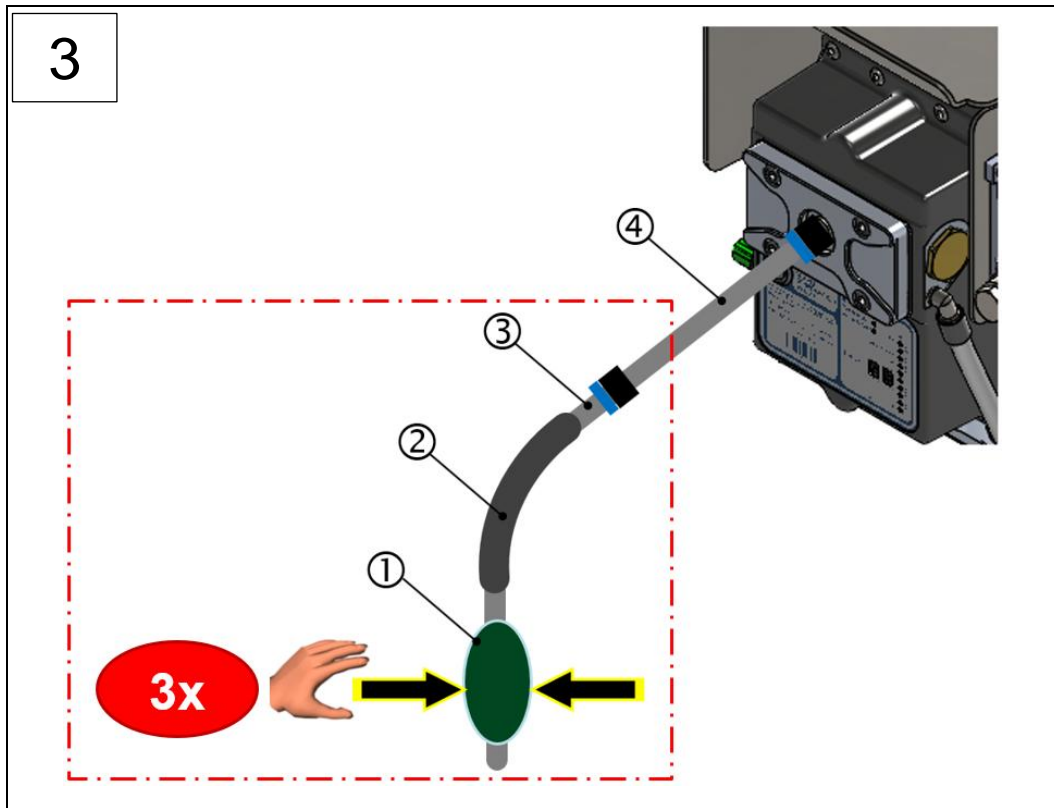

- 1: Hand pump
- 2: Smoke tube
- 3: Adapter
- 4: Flexible hose with push-in fitting

- ▶ Install the remaining hose parts (① to ③)
- ▶ For the function test: Press (①) at least 3 times

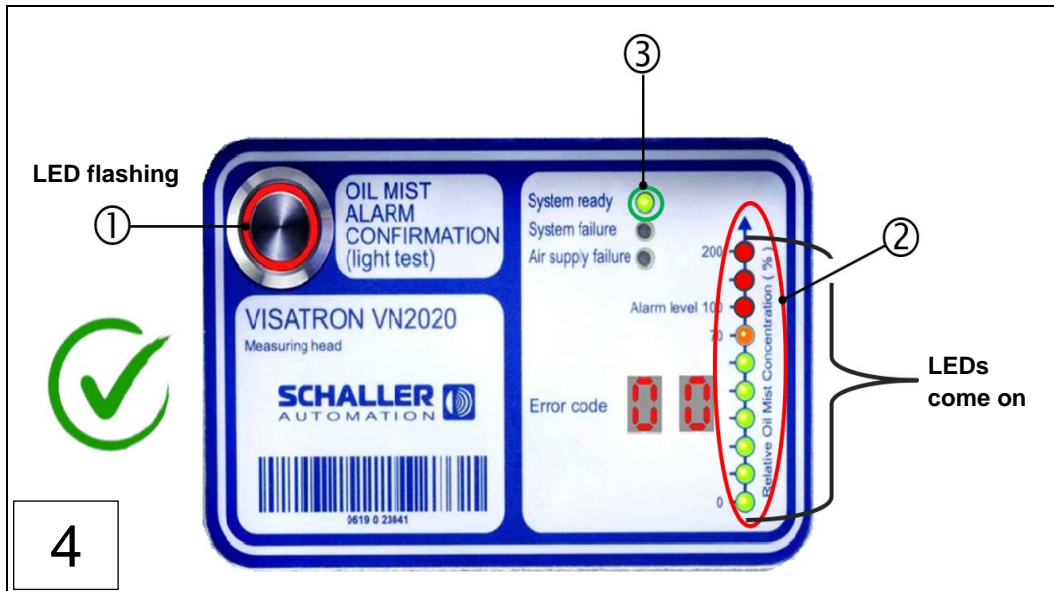

Fig.: 80 : Function test with test mist (steps 1-4)

- For the function test with test mist, the oil mist alarm is triggered within a few seconds at a relative oil mist concentration $\geq 100\%$, as shown in the figure above. In this case, the “Alarm level 100” LED on the LED bar display (right) turns red. (②)

- At the same time, the “Oil Mist Alarm” LED (top left) starts to flash **red**. (①)
- The “System ready” LED (③) stays **green**.
- If the opacity subsequently decreases, the alarm status is saved.

After a successful function test, the measuring head is returned to its initial state. To do this, carry out installation steps 1-3 in reverse order.

- ▶ Screw the screw plug (②) from installation step 1 back in, to a torque of 15 Nm.
- ▶ Finally, confirm the “Oil Mist Alarm” LED button (①) on the measuring head.
- ▶ Dispose of the smoke tube (③) from installation step 3 in accordance with this section.

The device is ready for operation!

9.1.5 Replacing the seal on the connecting box (8,000 hours)

To ensure reliable operation of the VN2020 oil mist detector, the seal on the connecting box has to be replaced after 8,000 operating hours at the latest. The seal (356950) is part of the Schaller maintenance kit (155006/155004) and can also be ordered separately from Schaller Automation if required.



NOTE

Maintenance work on the oil mist detector

- ▶ Observe the safety instructions in Section 9 → *Section 9 Maintenance and repair*



Fig.: 81 : Connecting box, VN2020 oil mist detector

1: Connecting box, VN2020

The seal is replaced according to the following steps:

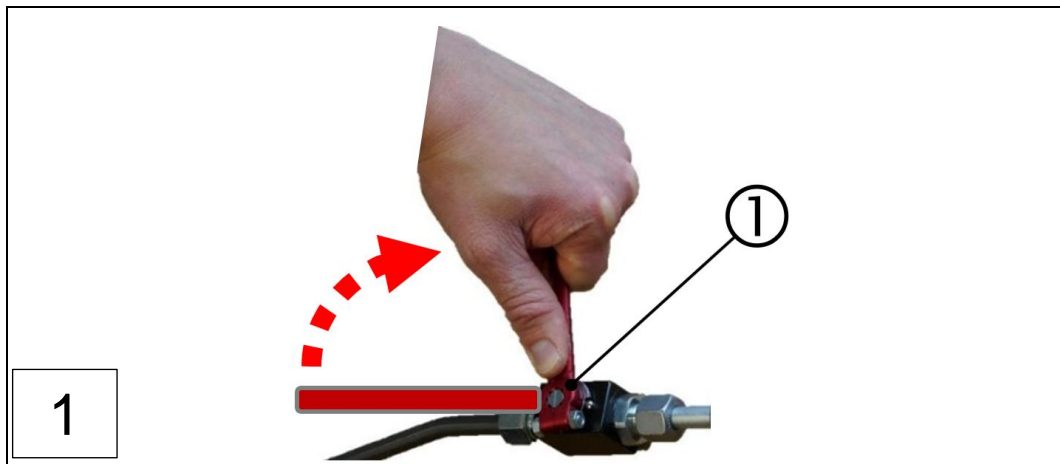

1: Shutoff lever valve (close)

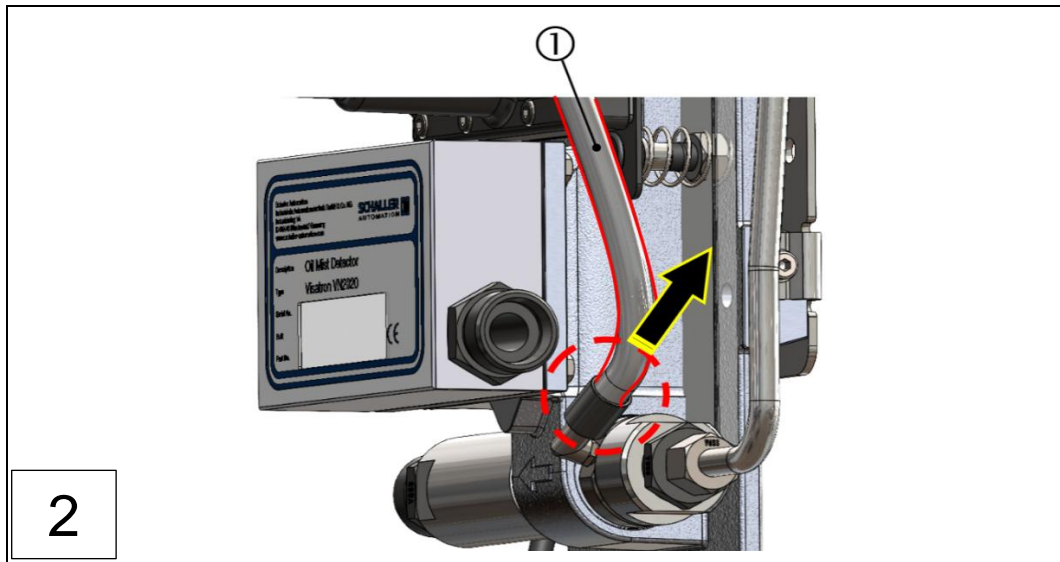

1: Remove the "venturi injector" compressed air hose

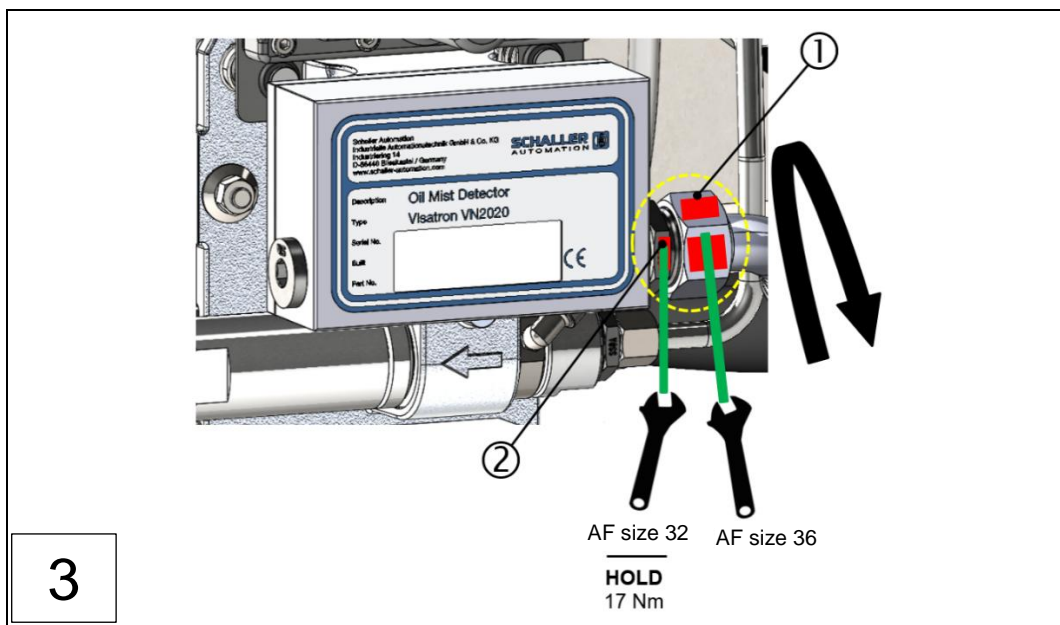

1: "Connecting box" union nut, VN2020

2: Pipe fitting L22

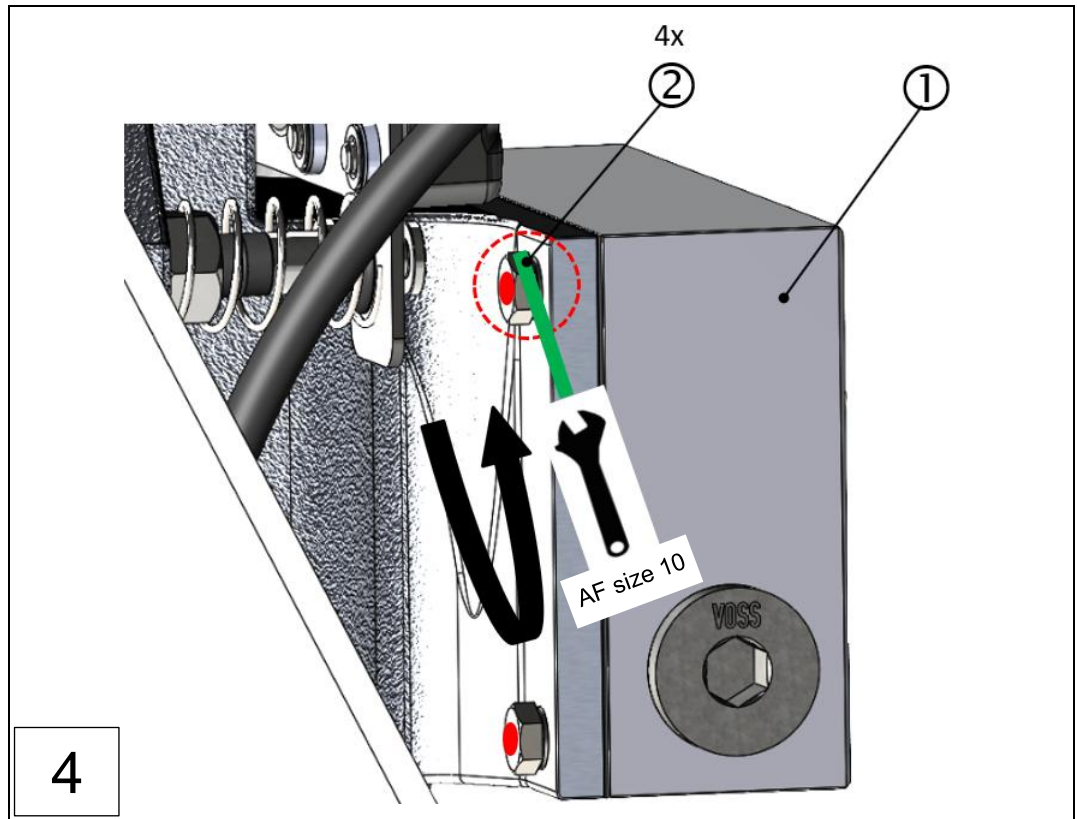

1: Connecting box

2: Connecting box fixing screws



NOTE

Risk of impact and crushing

- ▶ Hold the connecting box (①) by hand while loosening the fixing screws.

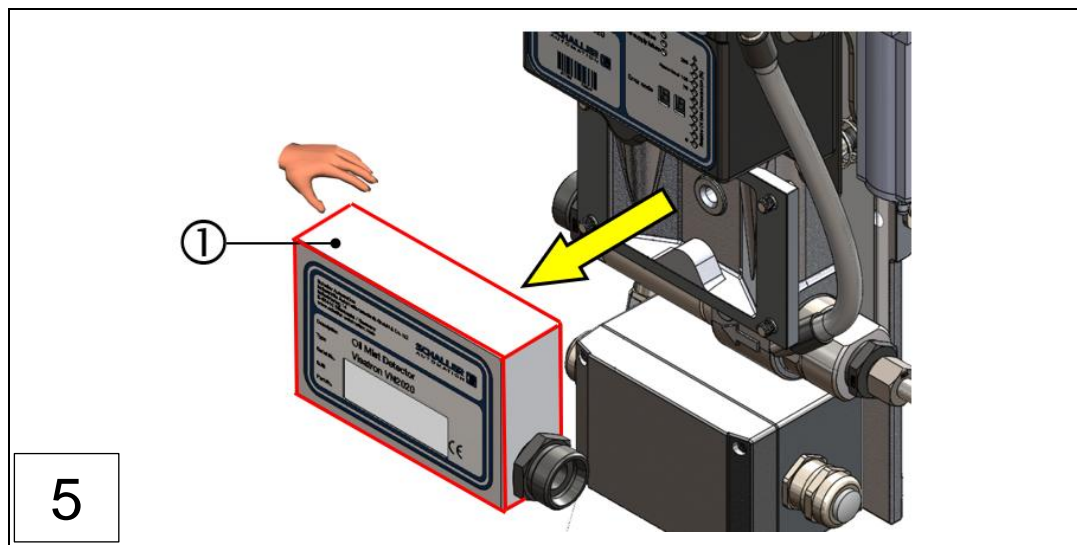

1: Connecting box, VN2020

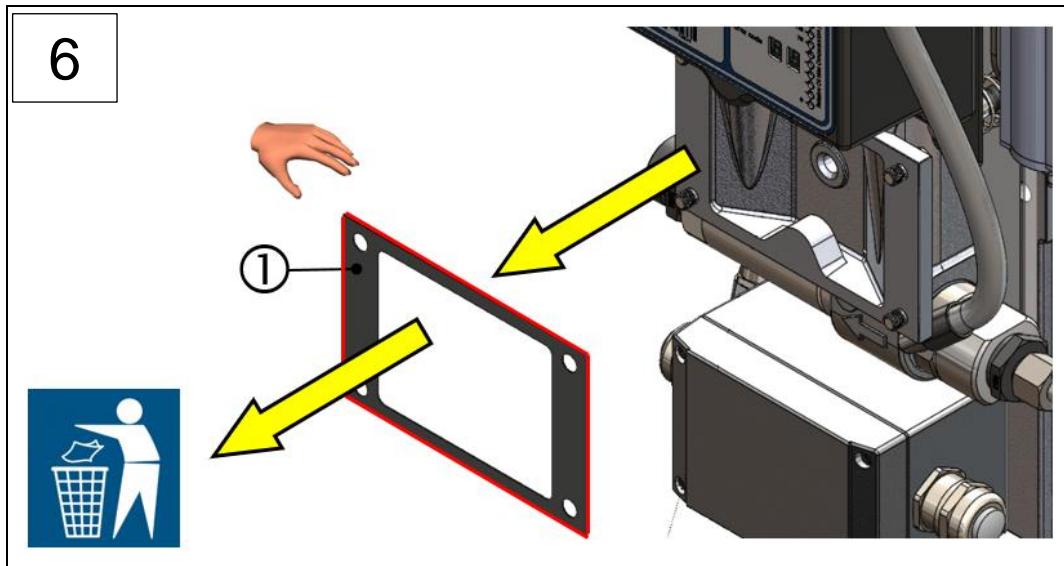

1: (Old) connecting box seal -> dispose of this

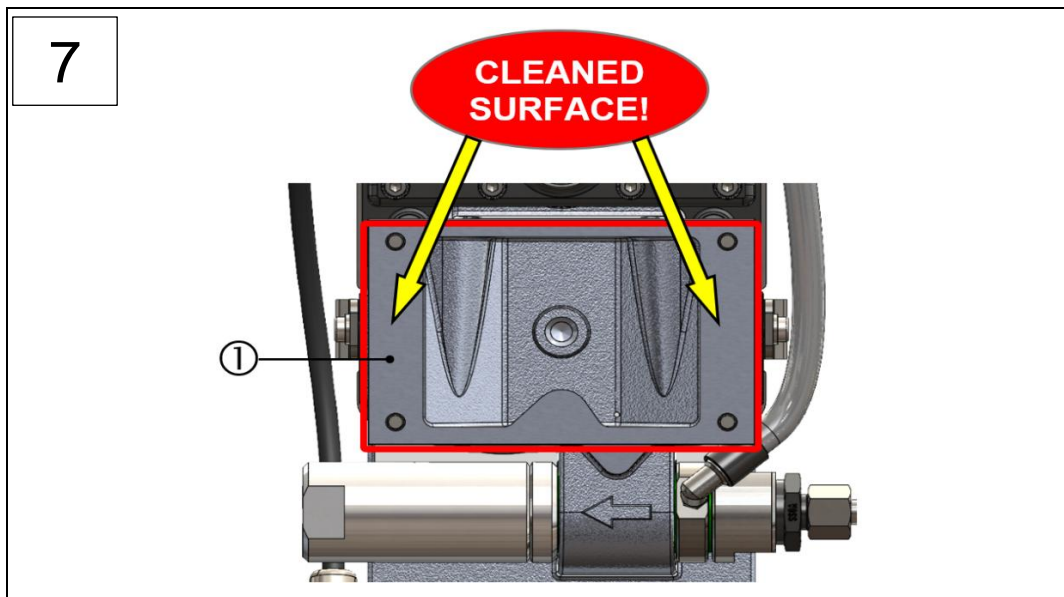

1: Connecting box sealing surface

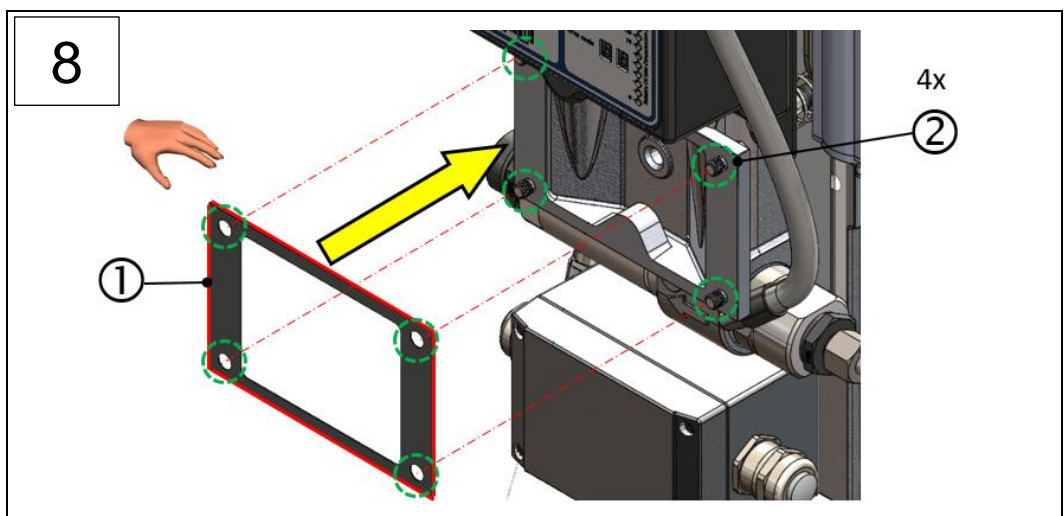

1: (New) connecting box seal

2: 4x fixing screws

- ☑ Position the **new seal** (①) for the connecting box using at least 2 existing hexagon head screws (②) with lock washer, which were previously removed in installation step 4.
- ☑ Cleaning the sealing surface (①) for the new seal of the connecting box completed successfully.

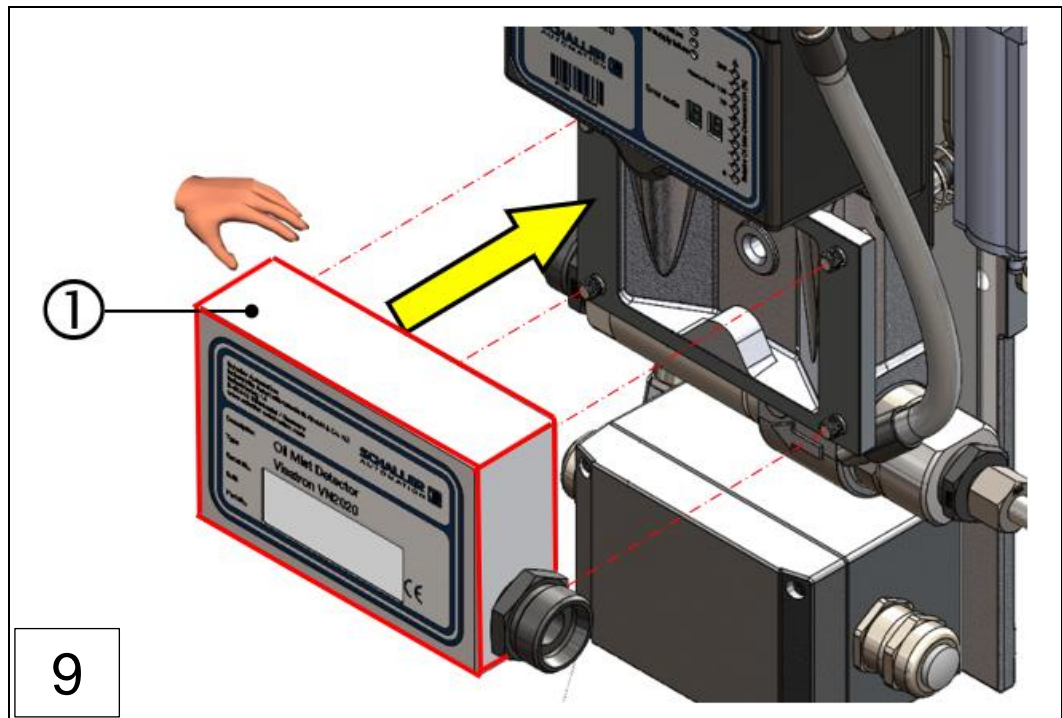

1: Connecting box, VN2020

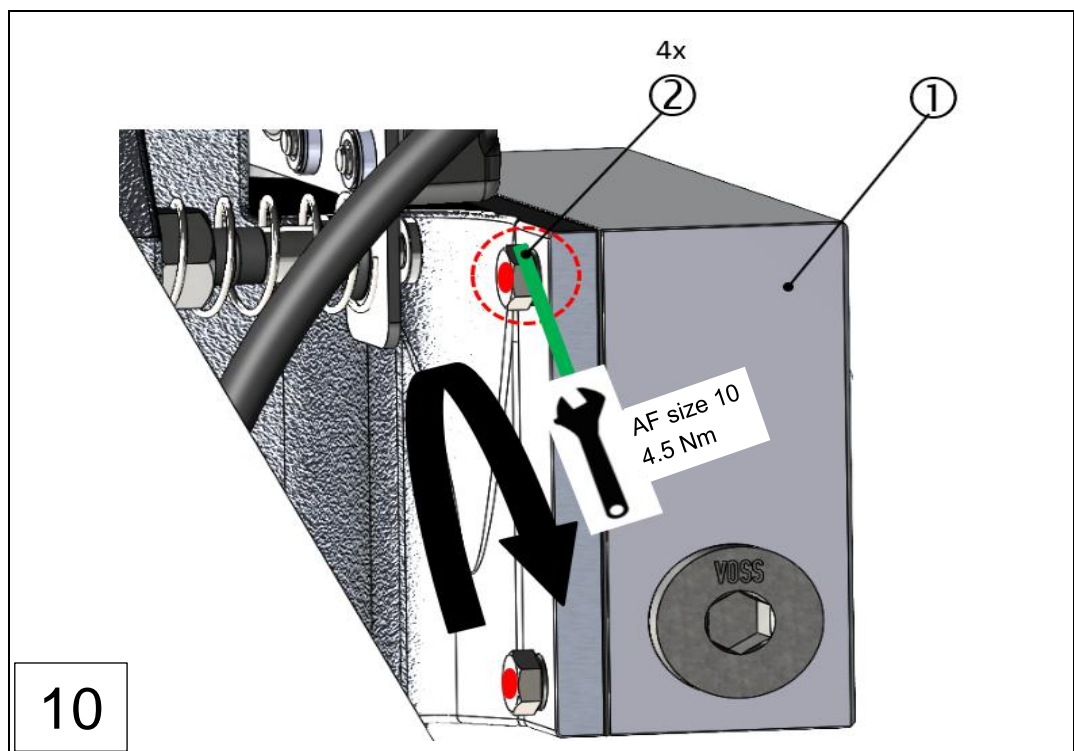

1: Connecting box

2: Connecting box fixing screws

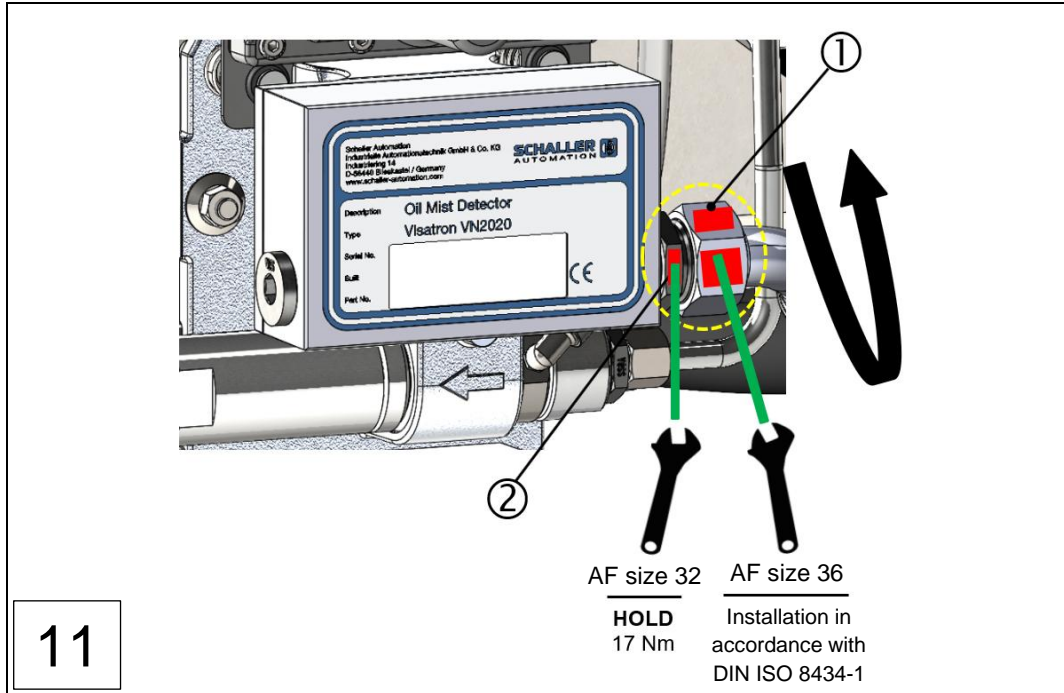

1: Connecting box union nut

2: Pipe fitting L22

- ▶ Tighten the union nut (①) of the pipe or hose connection by hand until you can feel that it is in contact with the screw fitting, cutting ring and union nut.

 **WARNING**

 **Risk of explosion**

- ▶ You must turn by the recommended number of turns for the union!

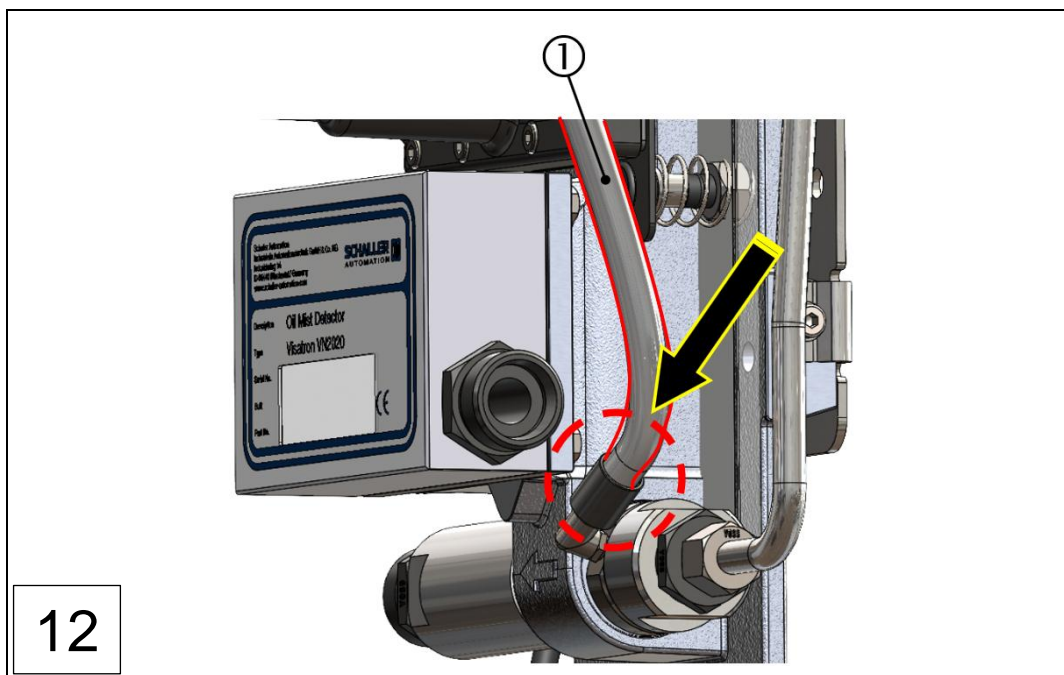

1: Install the "venturi injector" compressed air hose

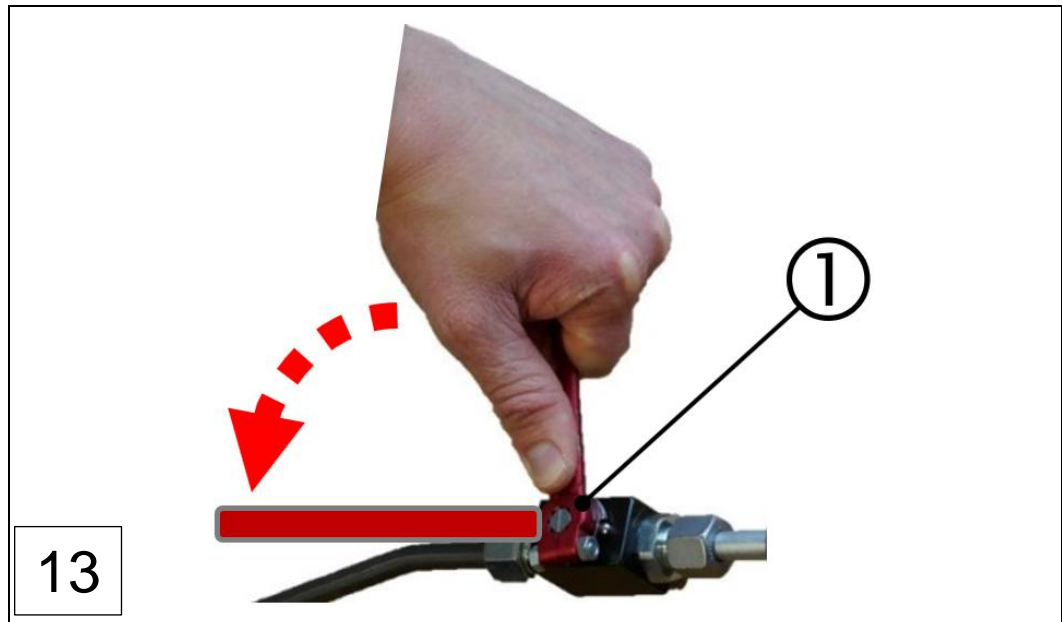

Fig.: 82 : Replacing the seal on the connecting box (steps 1- 13), VN2020

1: Shutoff lever valve (open)

The device is ready for operation!

9.2 Inspection of the oil mist detector (16,000 hours or after 24 months)

To ensure that the device is in proper working condition, defined maintenance and inspection work must be carried out by authorised and instructed specialist personnel.

In this case, an inspection by a Schaller service partner is required after 16,000 operating hours or after 24 months. See Section 12 (⇒ *Section 12 Contact*) in his manual for suitable partners or go to <https://schaller-automation.com/en/partners/>.

9.3 Repair by the operator



WARNING

Warning – risk of oil mist explosion during maintenance work

- ▶ When carrying out repair work, observe the safety instructions in Section 9. ⇒ *Section 9 Maintenance and repair*
- ▶ Also familiarise yourself with the basic safety instructions for working with the oil mist detector. ⇒ *Section 2.4 Basic safety instructions*
- ▶ If the oil mist detector is operated in explosion-proof areas, the relevant safety instructions must be observed. ⇒ *Section 2.4.1 Safety instructions for potentially explosive atmospheres*

Repair work includes replacing and repairing components and is only necessary if components have been damaged by wear or external circumstances.

Authorised specialist personnel must:

- ▶ carry out necessary repair work professionally according to the rules of technology and in accordance with the applicable regulations;
- ▶ observe the instructions for repairing the supplied parts in the relevant operating manuals supplied with the delivery;
- ▶ not make improvised repairs to worn or damaged components;
- ▶ replace worn or damaged components with spare parts; and
- ▶ Only use suitable spare parts. ⇒ *Section 13 Spare parts and accessories, VN2020/VN2020 EX*

The most important repair work is described below.

9.3.1 Replacing the VN2020/VN2020 EX measuring head

A properly functioning measuring head guarantees proper and reliable operation of the VN2020 oil mist detector. In the event of a defect or continuous malfunction, the measuring head has to be replaced. The measuring head is a spare part and can be ordered separately from Schaller Automation using the serial number, as follows:

- VN2020 measuring head: Part number 290044
- VN2020 EX: Part number 290045

The information on the name plate of the connecting box must be provided for queries regarding measuring head spare parts. Please use the return form to send us the necessary information.



NOTE

Maintenance work on the oil mist detector

- ▶ Observe the safety instructions in Section 9 ⇒ *Section 9 Maintenance and repair*



NOTE

Operation in potentially explosive atmosphere not safe

Risk of mixing up

- ▶ Please also note the clear identification features in
⇒ *Section 4.2 Component overview for the VISATRON® VN2020/VN2020 EX oil mist detector*



NOTE

Personal protective equipment

Operating the device or working on the device without protective equipment may result in serious injury. For the workplace PPE, the following protective equipment must be used:

- ▶ Safety glasses in accordance with DIN EN 166 or DIN EN 170.
- ▶ Safety helmet in accordance with DIN EN 397 or DIN EN 50365.
- ▶ ESD safety shoes according to ESD standard DIN EN 61340-5-1.

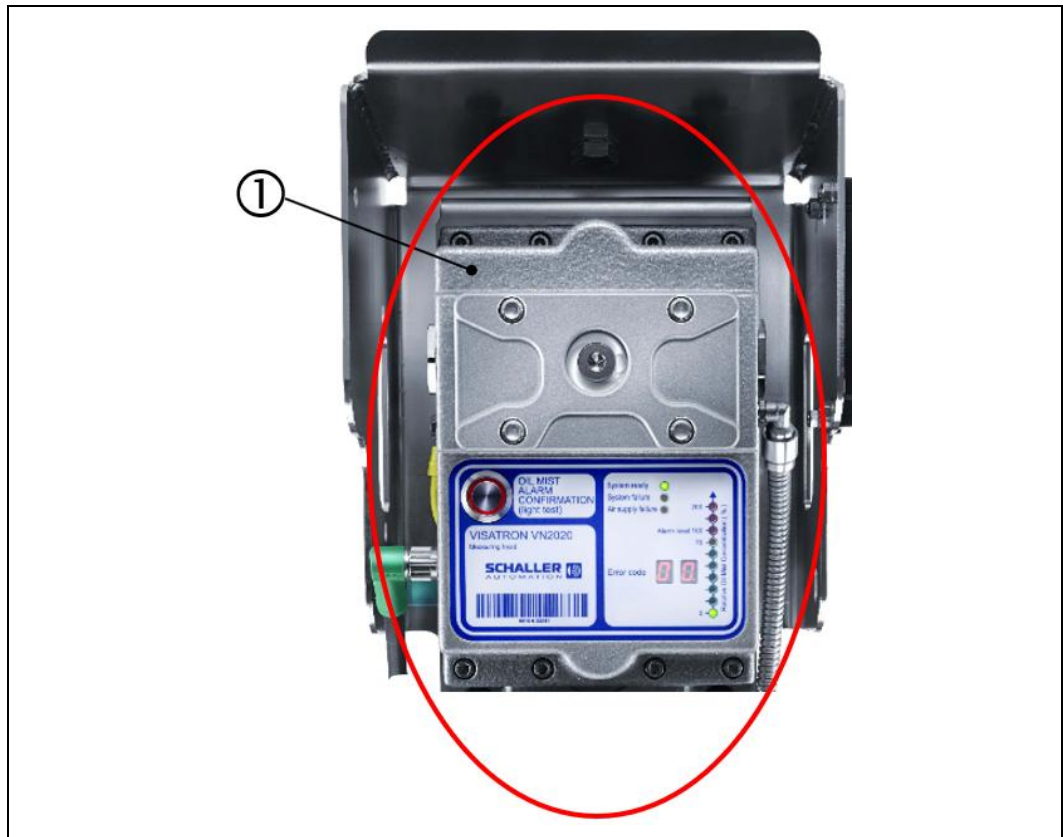



Fig.: 83 : Measuring head, VN2020 oil mist detector



1: VN2020 measuring head



The measuring head is replaced according to the following steps:



DANGER

- ▶ The measuring head may only be replaced with the engine switched off.
- ▶ The power and compressed air supply must be switched off before starting maintenance and repair work.





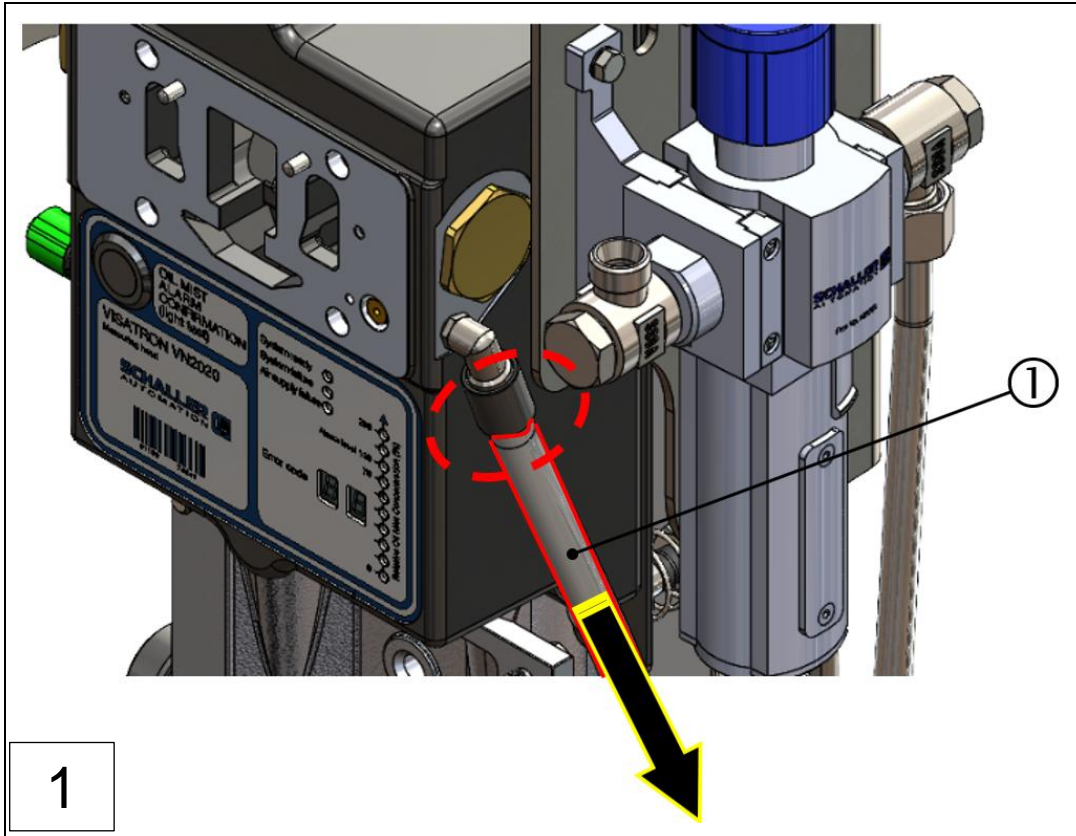

1: Installing the measuring head compressed air hose

- ▶ Pull the compressed air hose (①) off on the right side of the measuring head and then push to one side.

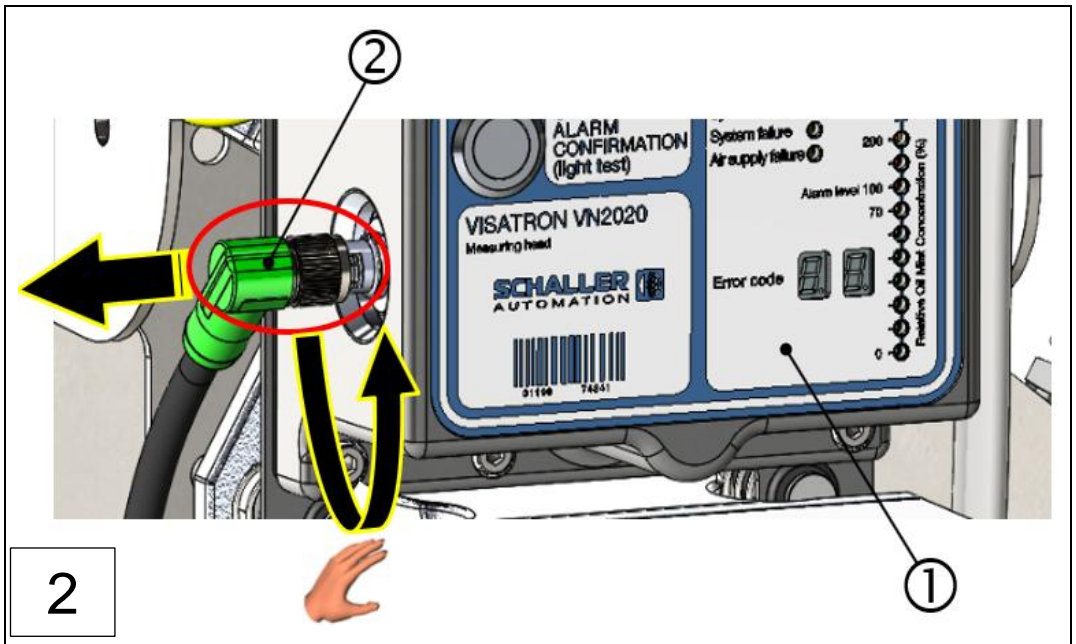

1: VN2020 measuring head

2: Measuring head plug connection, VN2020

- ▶ Loosen the union nut (②) of the plug-in connection on the left side by turning it anticlockwise and unplug the connector.

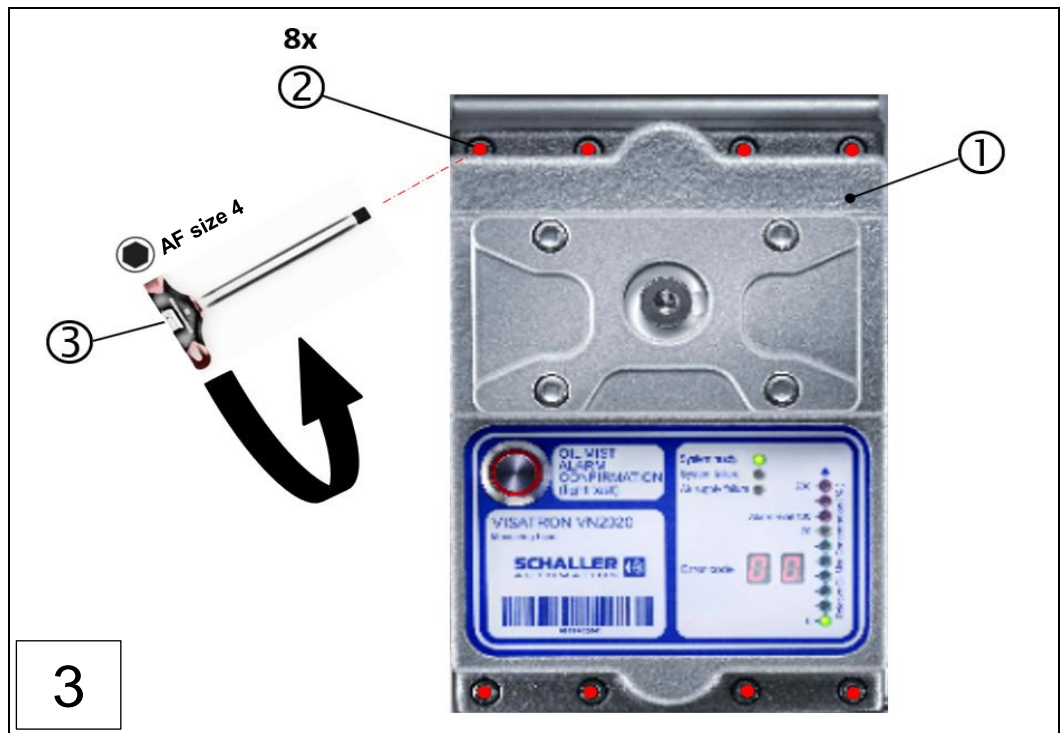

1: (Old) VN200 measuring head
3: Allen key, size 4

2: 8x neck collar bolts

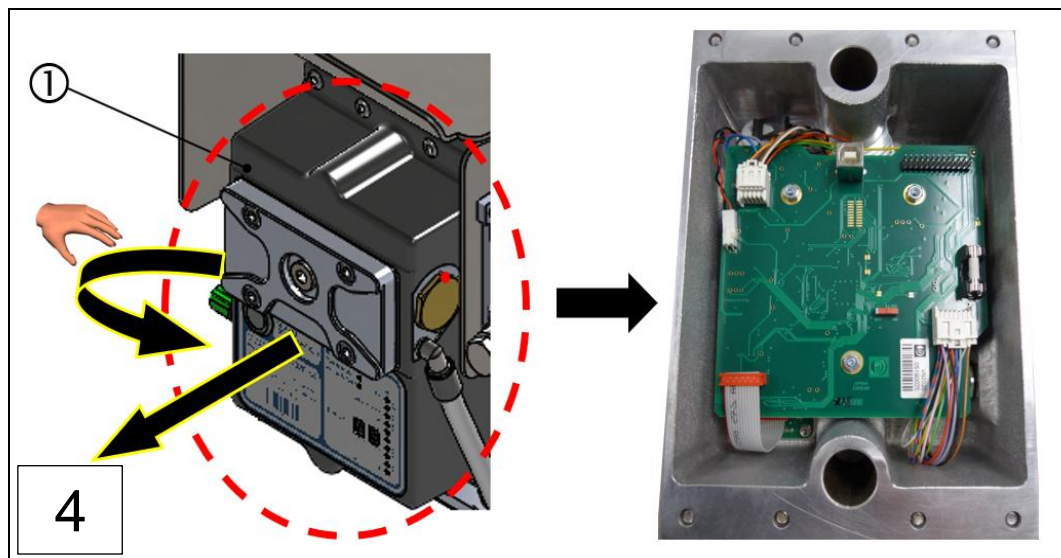

1: VN200 measuring head

NOTE



Risk of impact and crushing

- ▶ Hold the measuring head (1) by hand while loosening the fixing screws.

- ▶ Remove the measuring head and send it back to Schaller Automation. Remove the flat seal and dispose of the seal in accordance with local disposal regulations.

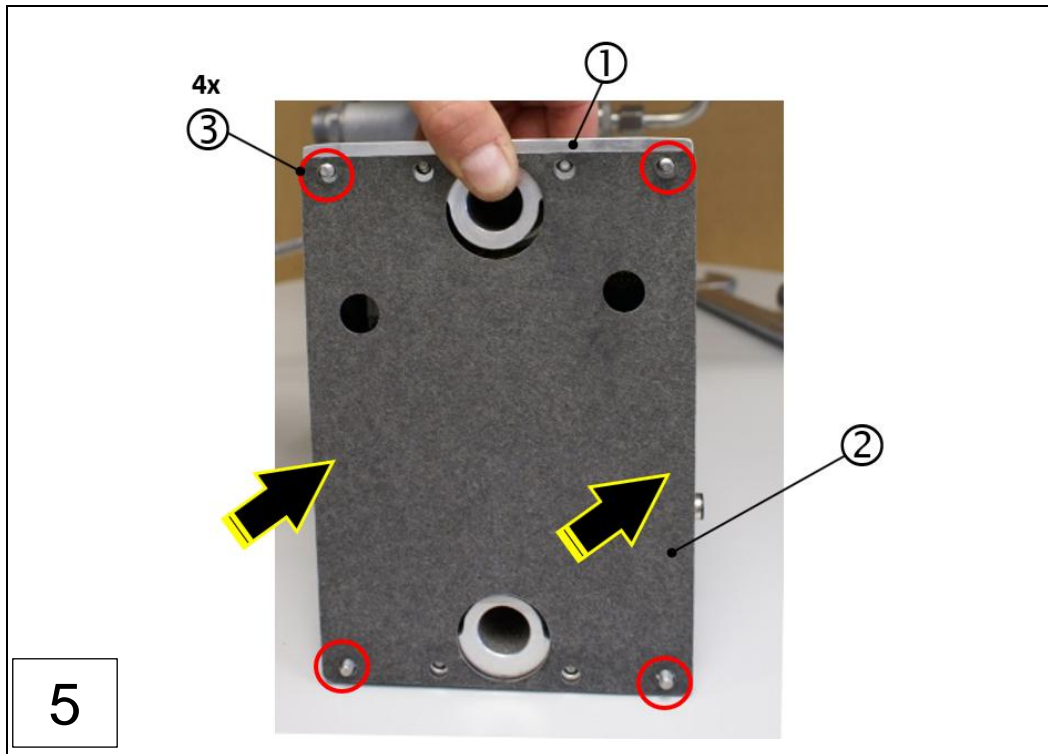

1: (New) VN2020 measuring head
3: Neck collar bolts

2: (New) measuring head seal, VN2020

- ▶ Place the new seal (supplied) (2) on the back of the new measuring head (1). Secure the seal by inserting two of the eight pre-assembled screws (3) through the four outer holes.

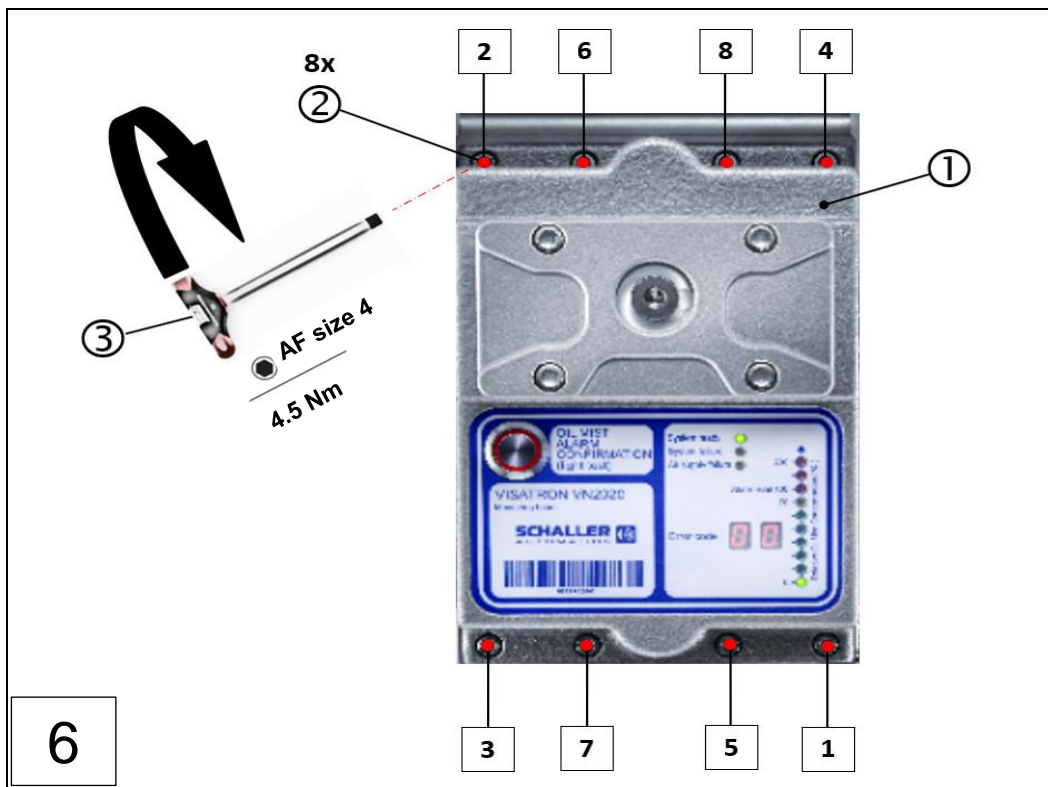

1: VN2020 measuring head
3: Allen key, size 4

2: 8x neck collar bolts

As soon as the measuring head has been successfully replaced, fasten the neck collar bolts (②) as shown in the figure above, observing the fastening sequence from ① to ⑧ and the defined tightening torque!

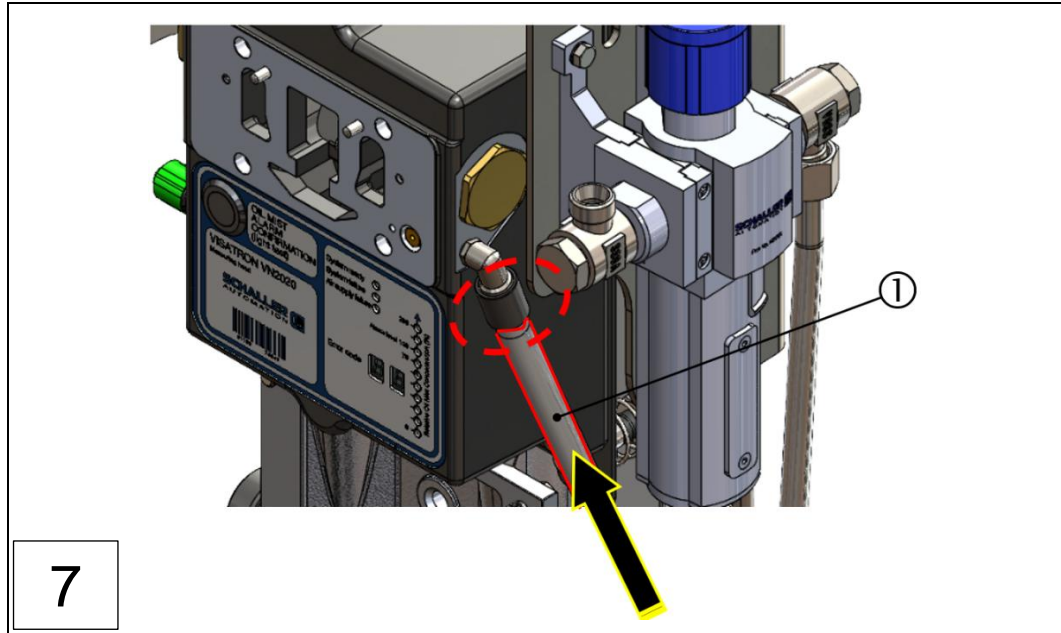

1: Measuring head compressed air hose, VN2020

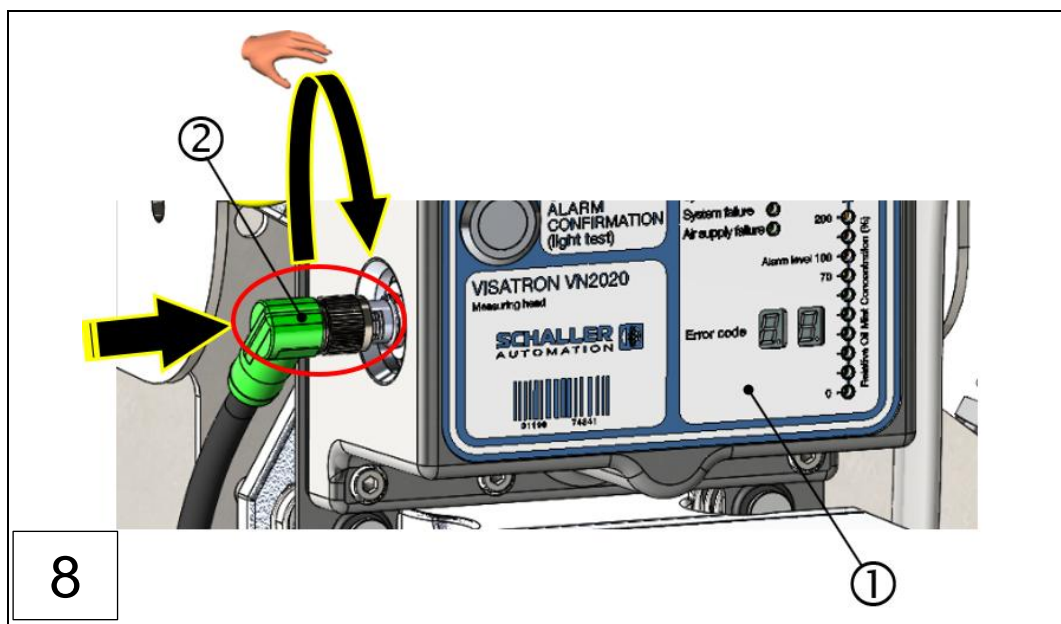

1: VN2020 measuring head

2: Measuring head plug connection, VN2020

NOTE

Checking the supply pressure on the oil mist detector

- ▶ After completing installation step 8, switch the power supply back on.
- ▶ After completing installation step 8, the supply pressure on the VN2020 measuring head has to be checked again and readjusted if necessary.
- ▶ To carry out installation step 9, first see Section 6.5.3
⇒ Section 6.5.3 Setting the negative pressure at the measuring head of the VN2020/VN2020 EX





Fig.: 84 : Replacing the VN2020 measuring head (steps 1-9)

- The measuring head on the VISATRON® VN2020 has been successfully replaced and the device is ready for operation!**

9.3.2 Replacing the fuse on the VN2020/VN2020 EX measuring head

To replace the fuse on the measuring head, start by carrying out steps 1-4 as described in Section 9.3.1. ⇒ Section 9.3.1 Replacing the VN2020/VN2020 EX measuring head

NOTE



Maintenance work on the oil mist detector

- ▶ Comply with the safety instructions for this in Section 9.3.1
⇒ Section 9.3.1. Replacing the VN2020/VN2020 EX measuring head

In the event of a defect, the fuse on the measuring head has to be replaced. The fuse is a spare part and can be ordered separately from Schaller Automation as follows:

VN2020 measuring head: Part number 290044/VN2020 EX: Part number 290045

- ▶ **Fuse: 436513**
- Fuse 5x20 medium time-lag 2A

Once step 4 has been successfully completed, please proceed as follows:

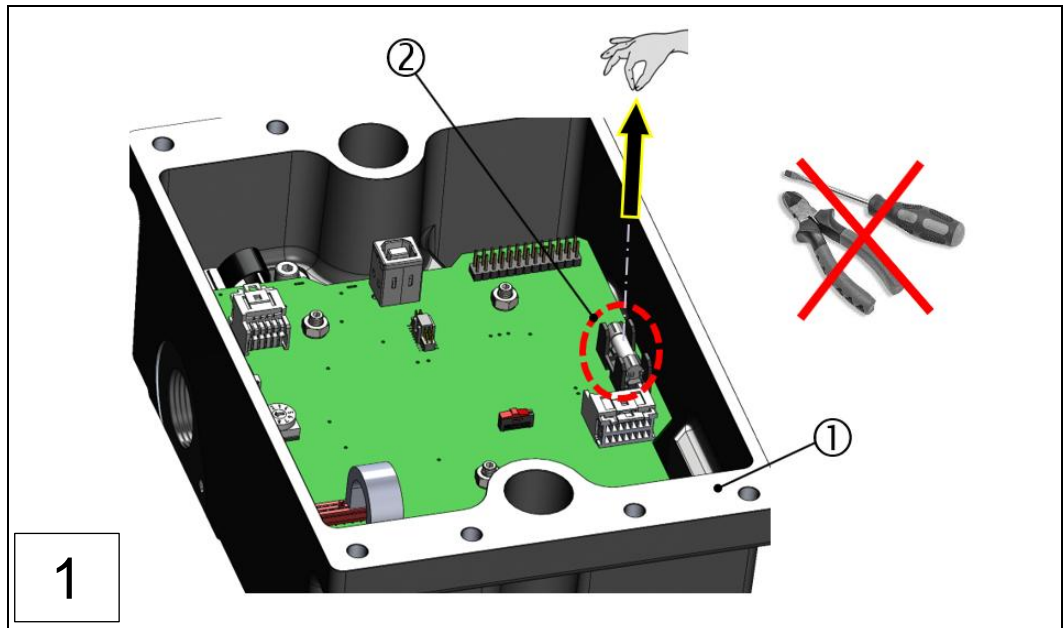

1: VN2020 measuring head

2: Fuse 5x20 medium time-lag 2A (old/defective)

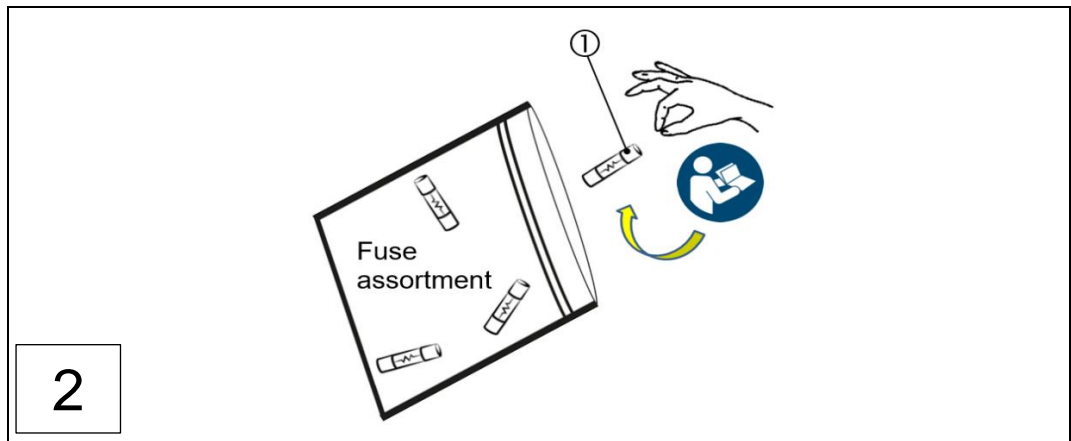

1: Fuse 5x20 medium time-lag 2A (new)

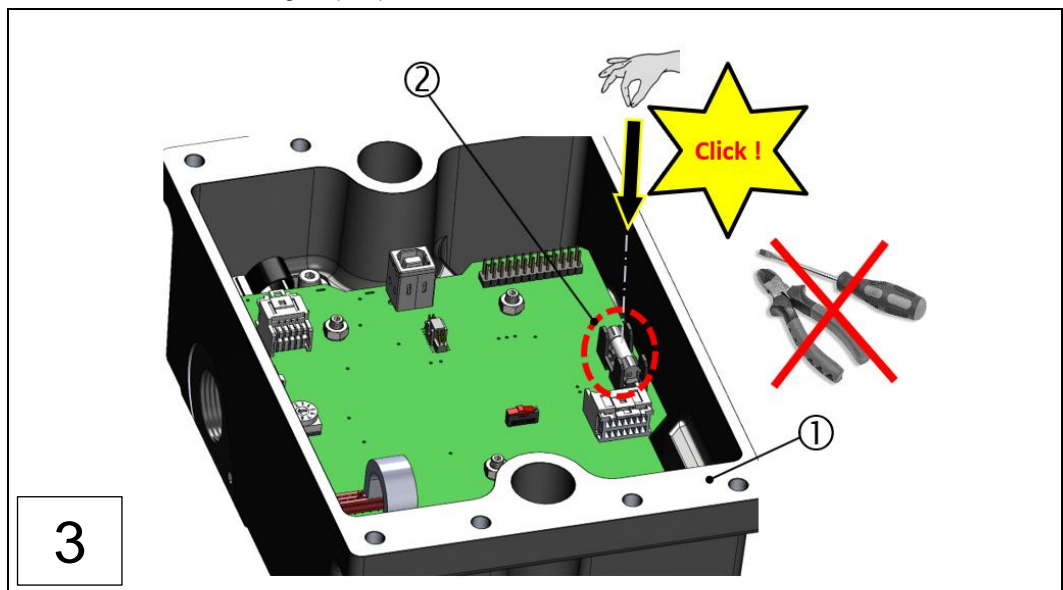

Fig.: 85 : Replacing the fuse on the VN2020 measuring head (steps 1-3)

1: VN2020 measuring head

2: Fuse 5x20 medium time-lag 2A (new)

Once you have successfully replaced the fuse, carry out steps 6-9 as described in Section 9.3.1. ⇒ Section 9.3.1 Replacing the VN2020/VN2020 EX measuring head

- The fuse on the VISATRON® VN2020 measuring head has been replaced successfully and the device is ready for operation!**

9.3.3 Replacing the seal on the inspection cover

To replace the seal on the inspection cover of the measuring head, carry out steps 1-2 and 6-8, as described in Section 9.1.2. ⇒ Section 9.1.2 Cleaning the light path on the measuring head (4,000 hours)



NOTE

Maintenance work on the oil mist detector

- ▶ Comply with the safety instructions for this in Section 9.1.2
⇒ Section 9.1.2. Cleaning the light path on the measuring head (4,000 hours)

The seal is a spare part and can be ordered separately from Schaller Automation as follows:

VN2020 measuring head: Part number 290044/VN2020 EX: Part number 290045

- ▶ **Inspection cover seal: 356952**

- The seal on the inspection cover has been successfully replaced and the device is ready for operation!**

9.3.4 Replacing the seal on the mounting plate

To replace the seal between the measuring head and the mounting plate, carry out the steps in Section 9.3.1. ⇒ Section 9.3.1 Replacing the VN2020/VN2020 EX measuring head



NOTE

Maintenance work on the oil mist detector

- ▶ Comply with the safety instructions for this in Section 9.3.1
⇒ Section 9.3.1. Replacing the VN2020/VN2020 EX measuring head

The seal is a spare part and can be ordered separately from Schaller Automation as follows:

VN2020 measuring head: Part number 290044/VN2020 EX: Part number 290045

- ▶ **Mounting plate seal: 356951**

- The seal on the mounting plate has been successfully replaced and the device is ready for operation!**

9.3.5 Replacing the inspection cover screw plug

The screw plug has to be replaced if there is **clearly** visible wear on the fitted O-ring (②):

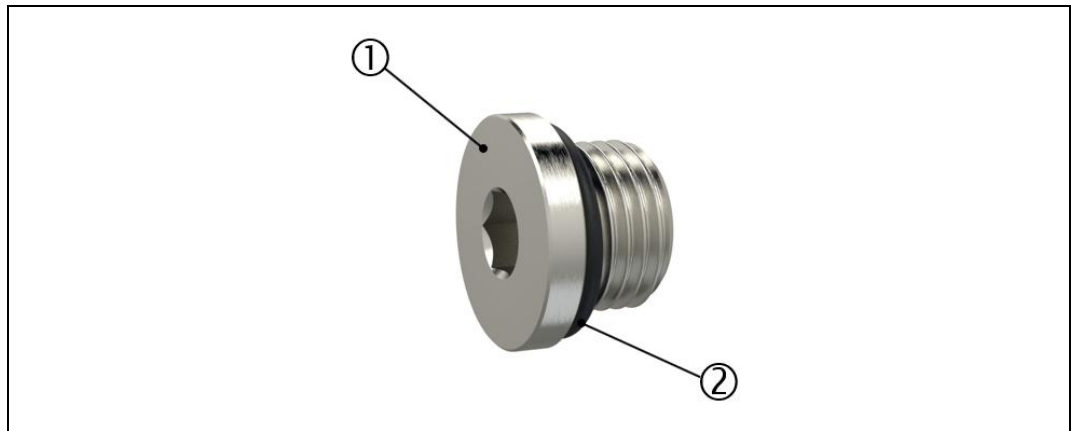

Fig.: 86 : VN2020 inspection cover screw plug

1: Screw plug

2: O-ring

The screw plug is a spare part and can be ordered separately from Schaller Automation as follows:

VN2020 measuring head: Part number 290044/VN2020 EX: Part number 290045

► “Inspection cover” screw plug: 366604



NOTE

Maintenance work on the oil mist detector

- Comply with the safety instructions for this in Section 6.5.3
⇒ Section 6.5.3. *Setting the negative pressure at the measuring head of the VN2020/VN2020 EX*

To replace the screw plug, carry out the following installation steps:

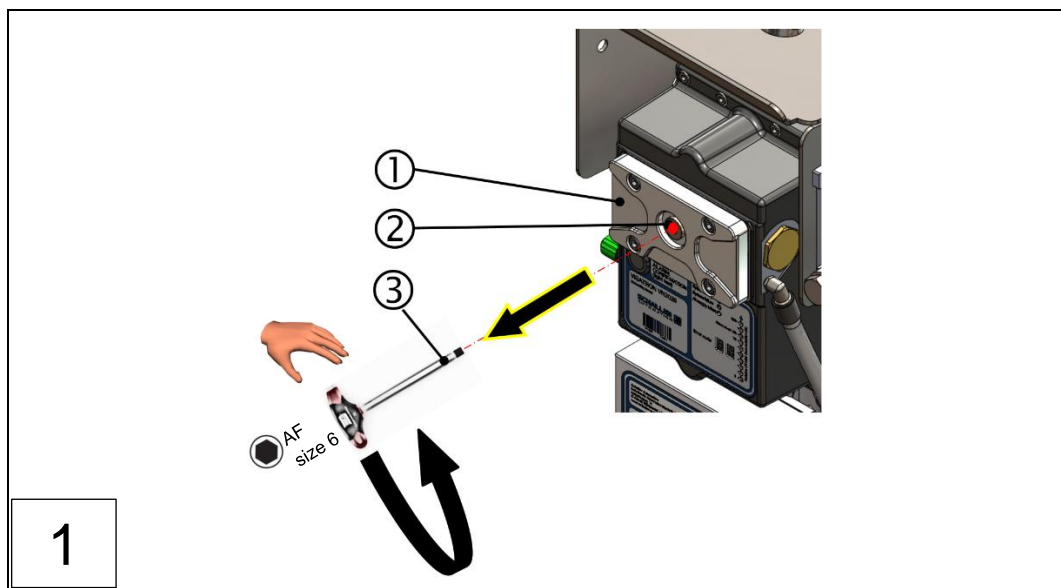

1: Inspection cover
3: Allen key, size 6

2: Screw plug (old)
(Torque spanner for up to 5 Nm)

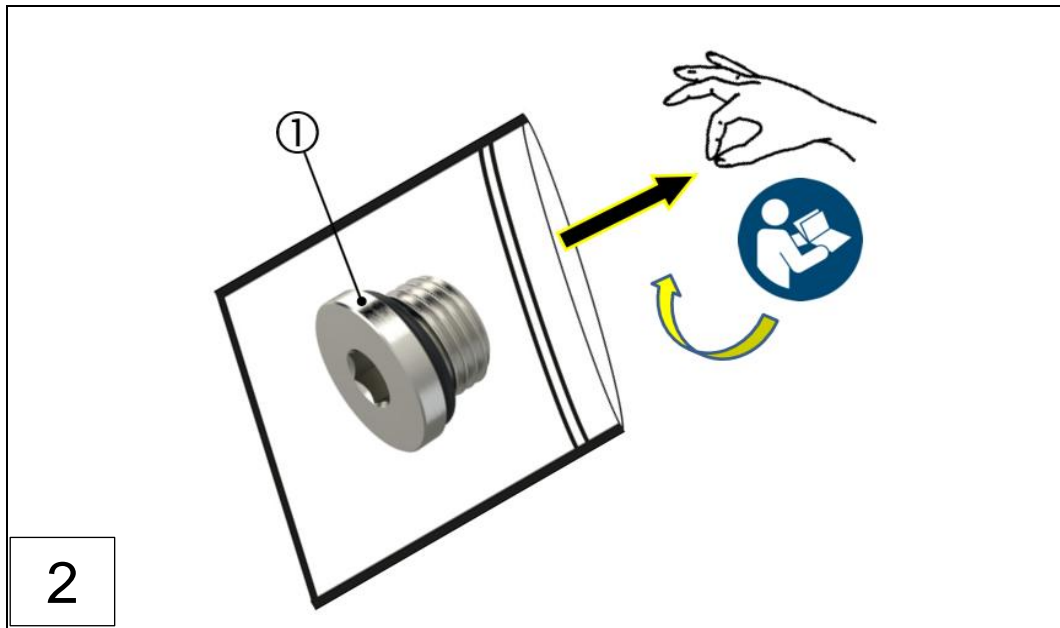

1: Screw plug (new)

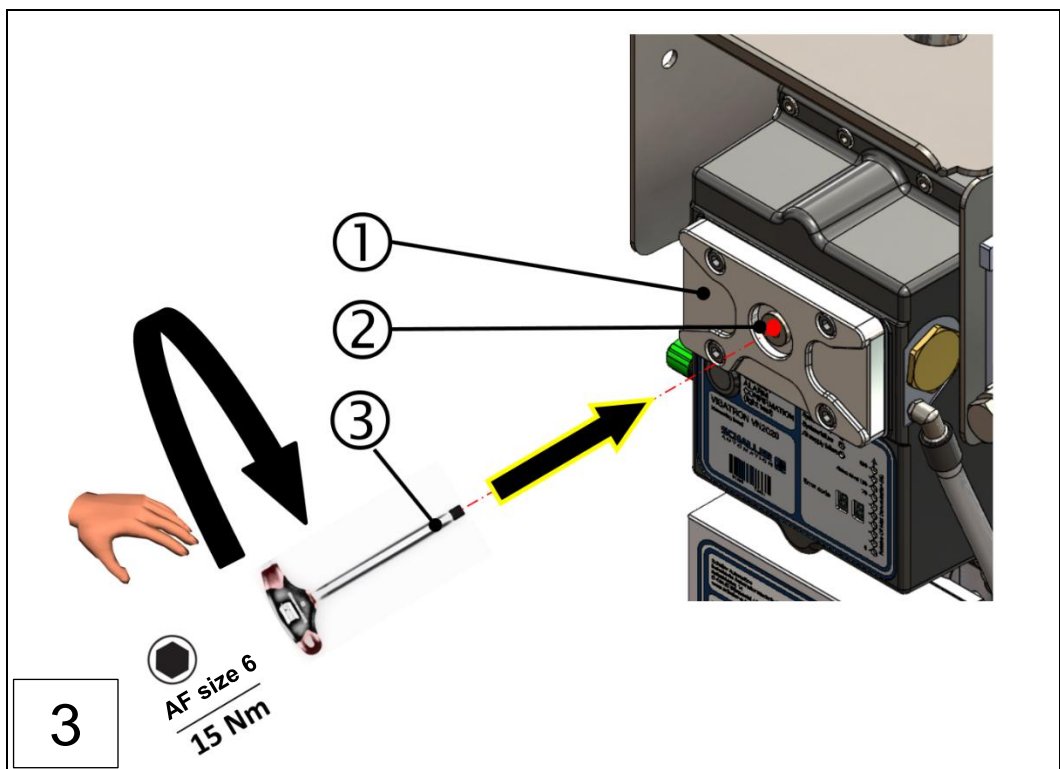

Fig.: 87 : Replacing the screw plug on the VN2020 measuring head (steps 1-3)

1: Inspection cover
3: Allen key, size 6

2: Screw plug (new)
(Torque spanner for 15 Nm)

► Finally, screw the screw plug (②) into the inspection cover to a torque of 15 Nm.

The screw plug on the inspection cover has been successfully replaced and the device is ready for operation!

9.3.6 Replacing the terminal box on the VN2020/VN2020 EX

If the terminal box has a defect or malfunction, it has to be replaced. The terminal box is a spare part and can be ordered separately from Schaller Automation as follows:

VN2020 measuring head: Part number 290044/VN2020 EX: Part number 290045

▶ **Terminal box: 290043**



NOTE

Maintenance work on the oil mist detector

- ▶ Observe the safety instructions in Section 9 ⇒ *Section 9 Maintenance and repair*
- ▶ Insert the appropriate wire break resistor, after replacing the terminal box, in accordance with Section 6.4.2.1 ⇒ *Section 6.4.2.1 Configuration of the wire break resistors on the VN2020 terminal box.*



NOTE

Personal protective equipment

Operating the device or working on the device without protective equipment may result in serious injury. For the workplace PPE, the following protective equipment must be used:



- ▶ Safety glasses in accordance with DIN EN 166 or DIN EN 170.
- ▶ Safety helmet in accordance with DIN EN 397 or DIN EN 50365.
- ▶ ESD safety shoes according to ESD standard DIN EN 61340-5-1.



Fig.: 88 : Terminal box (spare part), VN2020

The terminal box is replaced according to the following steps:



DANGER

- ▶ The terminal box may only be replaced with the engine switched off.
- ▶ The power and compressed air supply must be switched off before starting maintenance and repair work.
- ▶ Before starting work, the housing of the VISATRON® VN2020/VN2020 EX oil mist detector must be earthed.

⇒ Section 6.4.6 Connecting housing earth to the protective cover of the VN2020

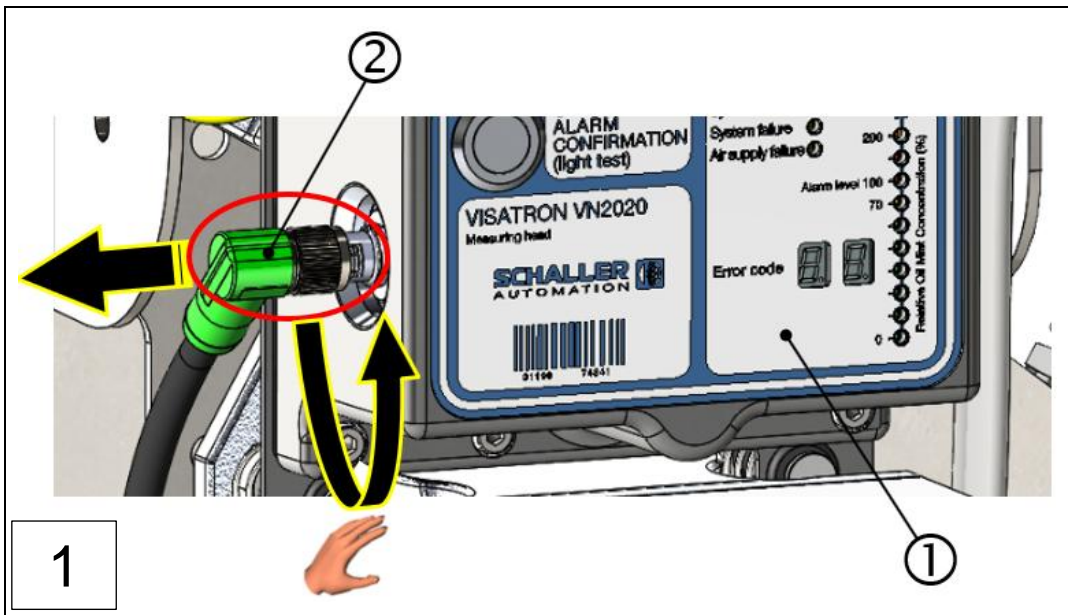

1: VN2020 measuring head

2: Measuring head plug connection, VN2020

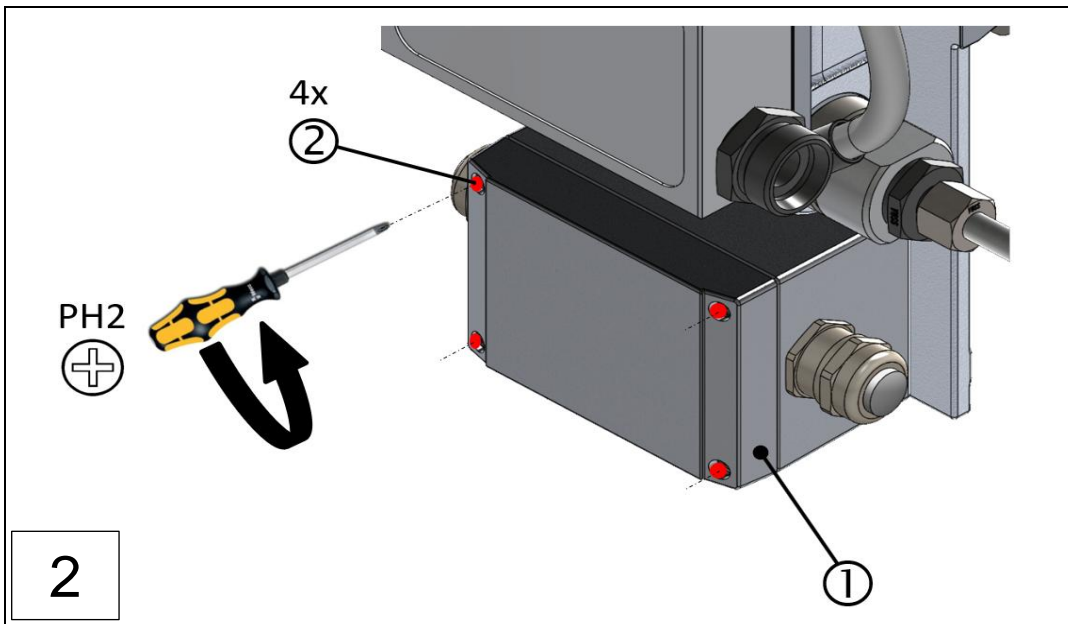

1: Cover, VN2020 terminal box

2: Fixing screws

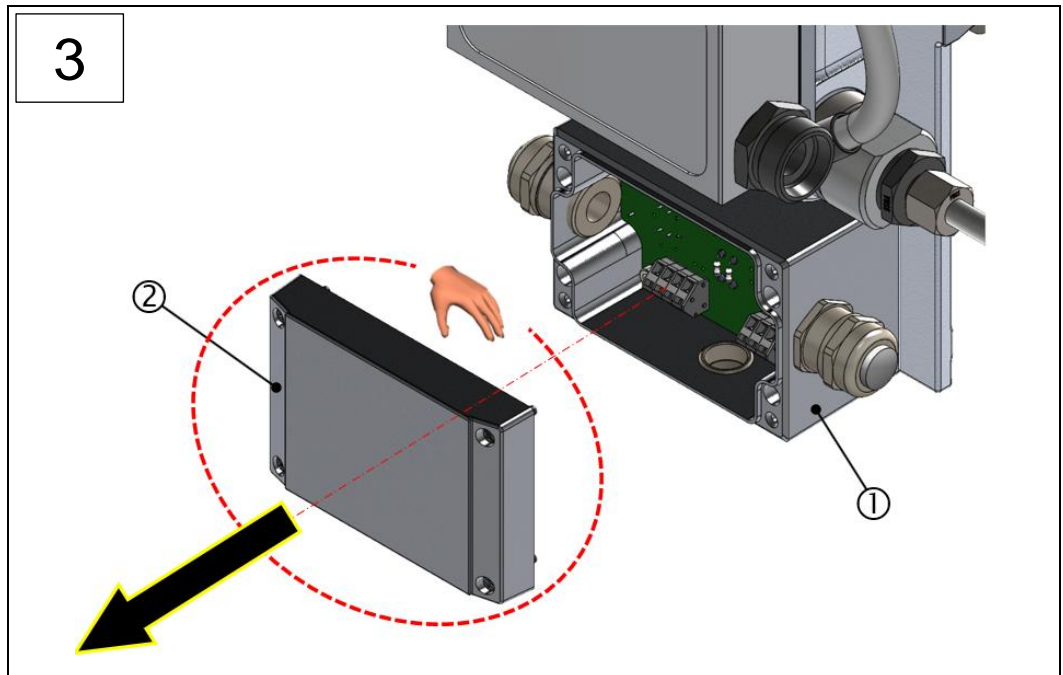

1: VN2020 terminal box

2: Cover, VN2020 terminal box

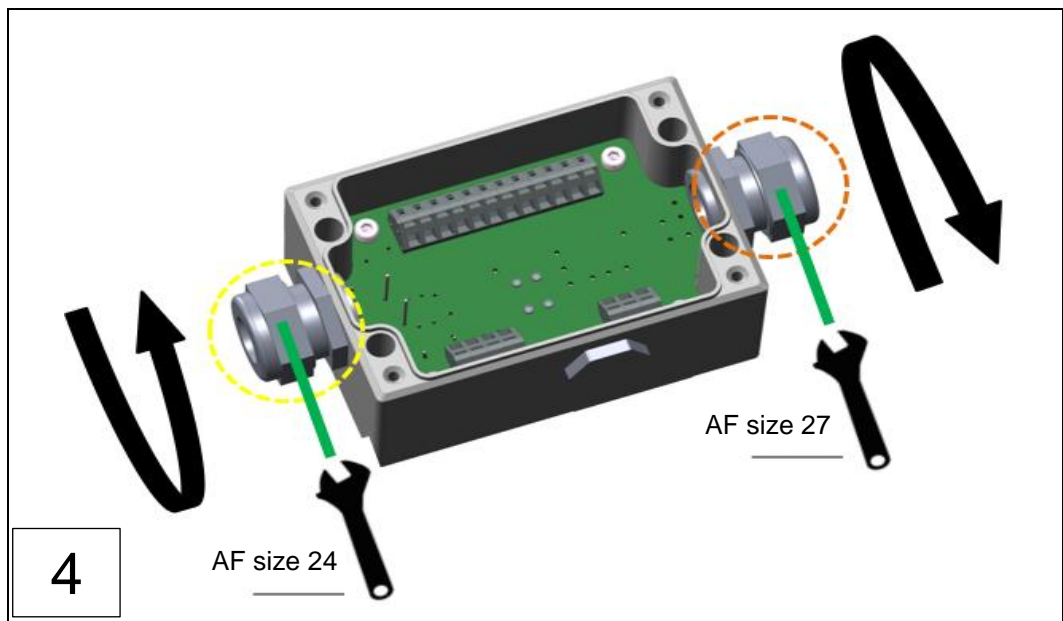

4

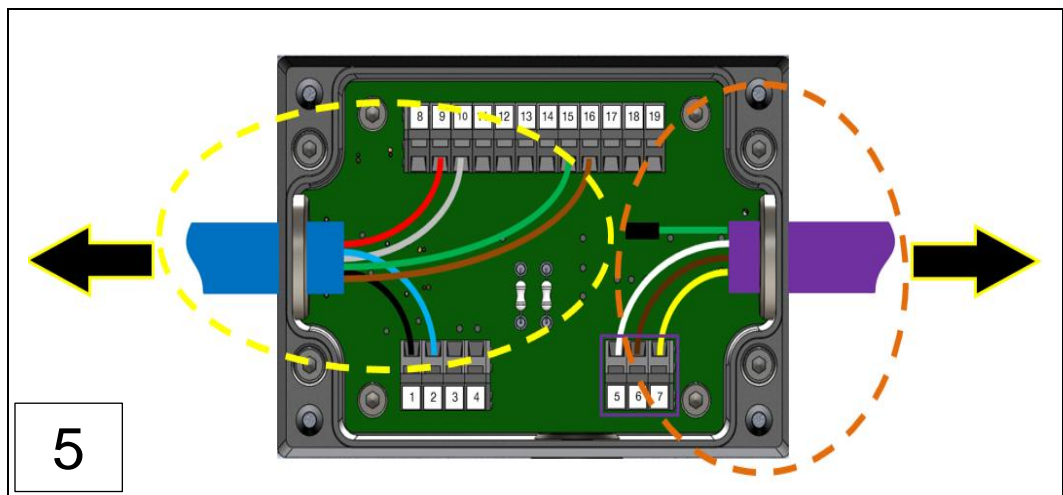

5

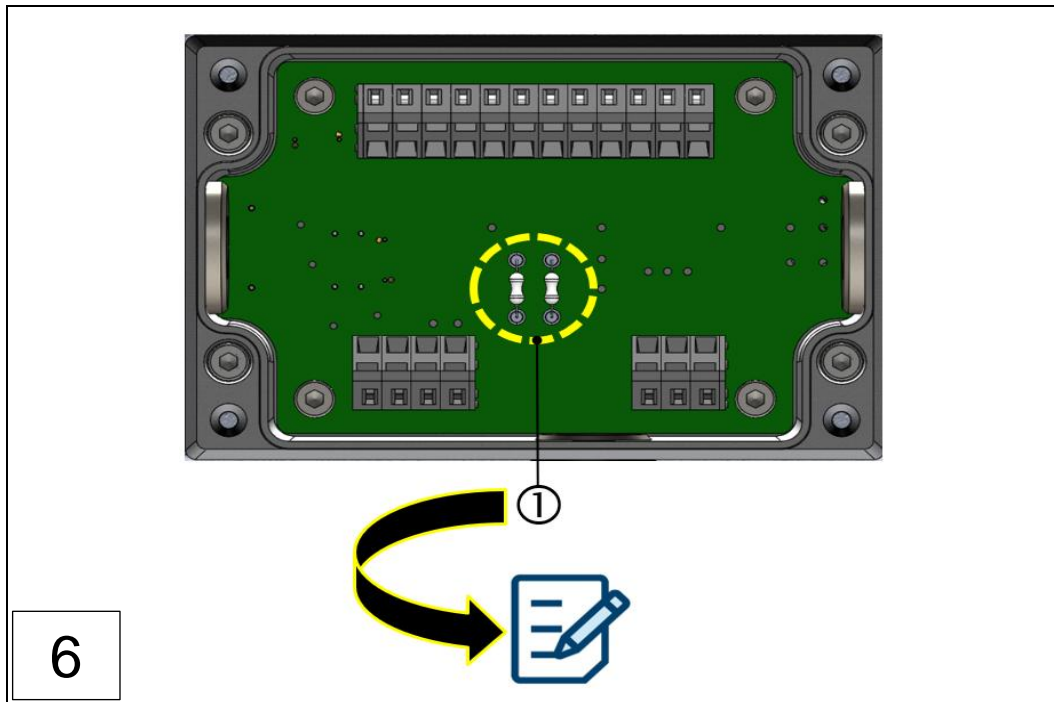

1: Wire break resistors

- ▶ Make a note of the value/colour coding of the two wire break resistors.

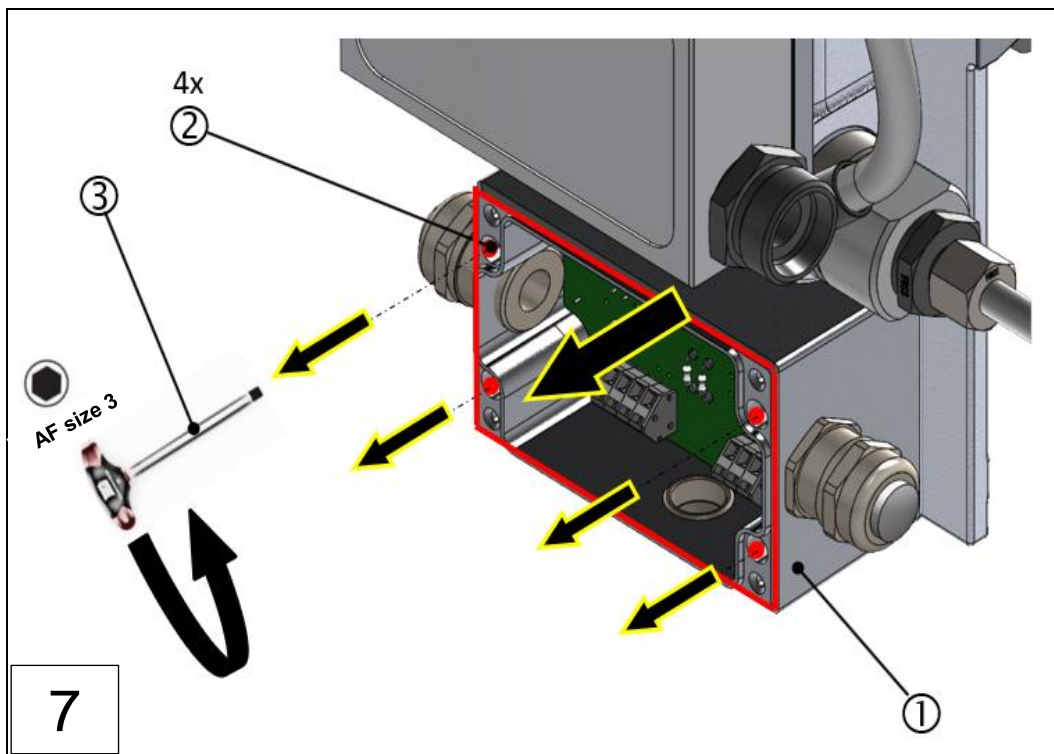

1: VN2020 terminal box (old)

2: 4x neck collar bolts

3: Allen key, size 3

- ▶ Loosen the neck collar bolts (4 pcs.) (②).
- ▶ Remove the (old) terminal box (①).
- ▶ Then dispose of the (old) terminal box or return it to Schaller Automation.

- ▶ Now take the new terminal box and remove the cover as described in step 2 in this section and store it for use later on.
⇒ Section 9.3.6 Replacing the terminal box on the VN2020/VN2020 EX
- ▶ Take two suitable wire break resistors from the supplied bag, which you have previously identified in accordance with step 6 in this section.
- ▶ Insert the two wire break resistors into the circuit board in accordance with Section 6.4.2.1.
⇒ Section 6.4.2.1 Configuration of the wire break resistors on the VN2020 terminal box.

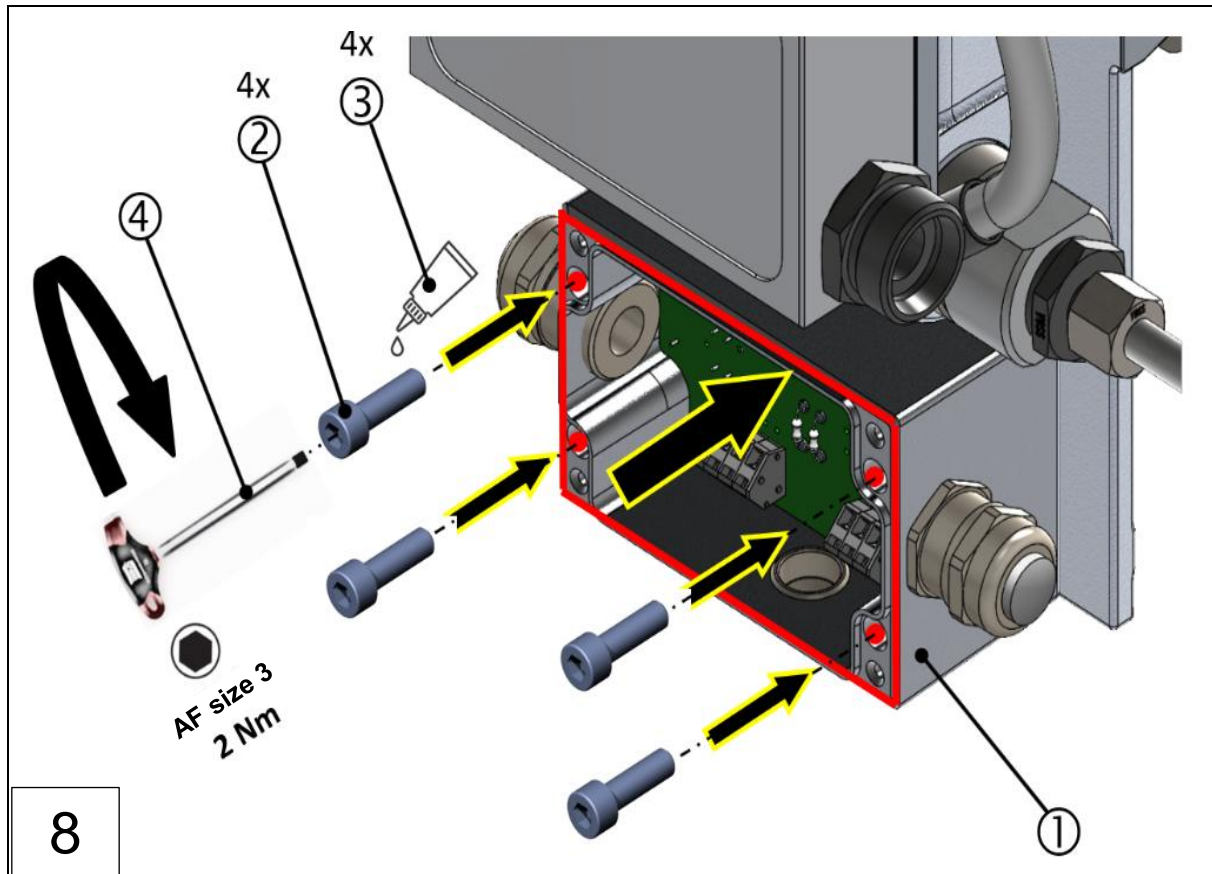

- | | |
|-------------------------------|---|
| 1: Terminal box (new) | 2: 4x neck collar bolts (new) |
| 3: Threadlocker (Loctite 243) | 4: Allen key, AF size 3 (torque spanner for up to 5 Nm) |

- ▶ As soon as the terminal box has been successfully replaced, first apply Loctite 243 (③) threadlocker to the neck collar bolts (②) and then fit them as shown in the figure above. Please note the fastening sequence, which is crosswise, and the defined tightening torque!
- ▶ Finally, carry out steps 1-5 of this section in reverse order.

When carrying out the final installation steps, comply with the following instructions:

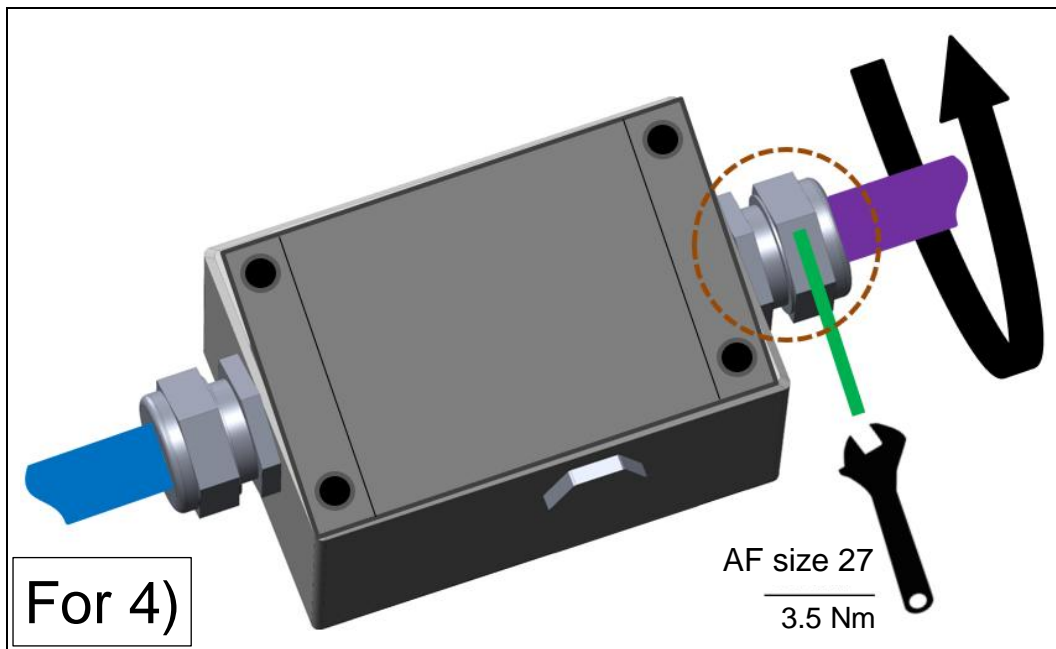
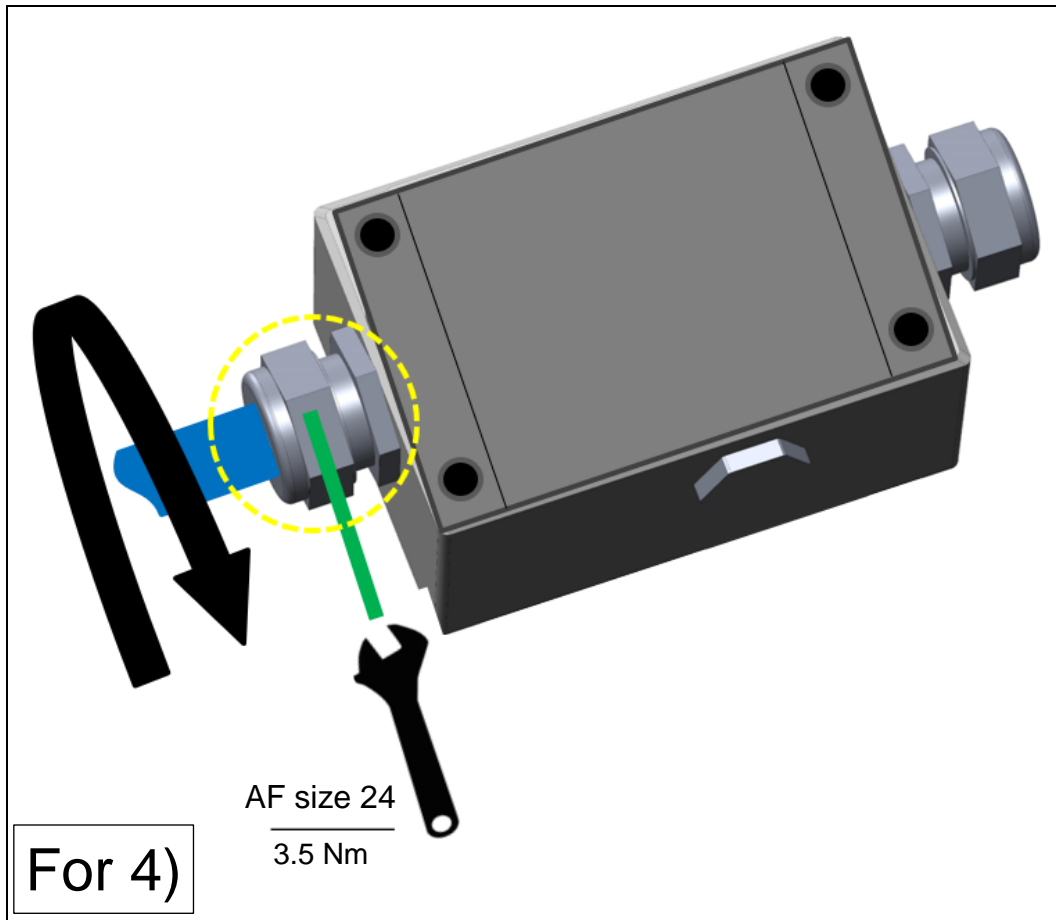

After the electrical installation, the terminal box on the VN2020 is closed again, as shown in the figure below. Tighten the screws crosswise in this case. Then re-establish the electrical connection between the terminal box and the measuring head.

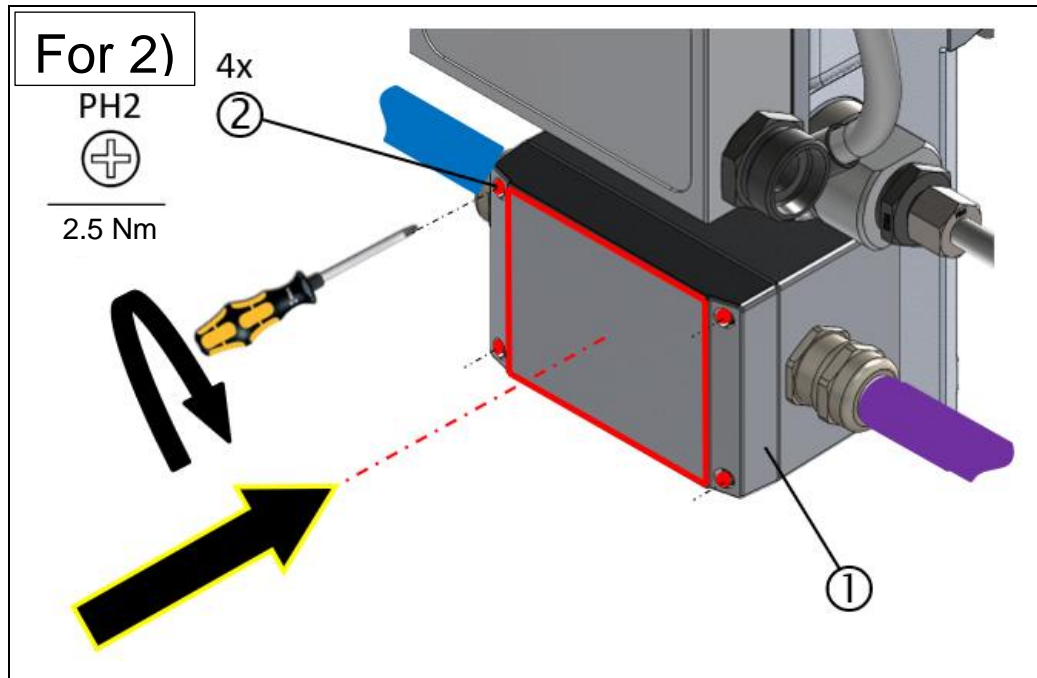
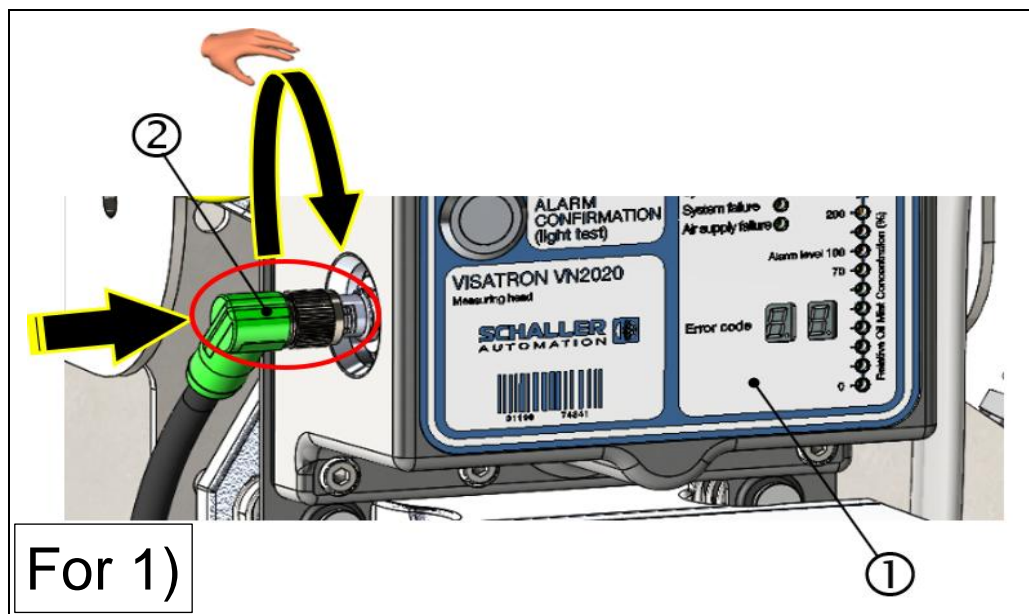

Fig.: 89 : Replacing the VN200 terminal box (installation steps 1-8)

1: Cover, VN200 terminal box

2: 4x fixing screws



1: VN200 measuring head

2: Measuring head plug connection, VN200

NOTE



Switching on the power supply to the oil mist detector

- ▶ After completing the installation steps, switch the power supply back on.

The terminal box has been successfully replaced and the device is ready for operation!

9.3.7 Replacing the filter control valve on the VN2020/VN2020 EX

If the filter control valve (the pressure regulator unit) has a defect or malfunction, it has to be replaced. The filter control valve is a spare part and can be ordered separately from Schaller Automation as follows:

- ▶ **Filter control valve: 273456/273461**



NOTE

Maintenance work on the oil mist detector

- ▶ Observe the safety instructions in Section 9 ⇒ *Section 9 Maintenance and repair*



DANGER

- ▶ There are two versions of the filter control valve in total, which must not be mixed up!
- ▶ The filter control valve may only be replaced with the engine switched off.
- ▶ The compressed air supply must be switched off before starting maintenance and repair work.



NOTE

Personal protective equipment

Operating the device or working on the device without protective equipment may result in serious injury. For the workplace PPE, the following protective equipment must be used:



- ▶ Safety glasses in accordance with DIN EN 166 or DIN EN 170.
- ▶ Safety helmet in accordance with DIN EN 397 or DIN EN 50365.
- ▶ ESD safety shoes according to ESD standard DIN EN 61340-5-1.

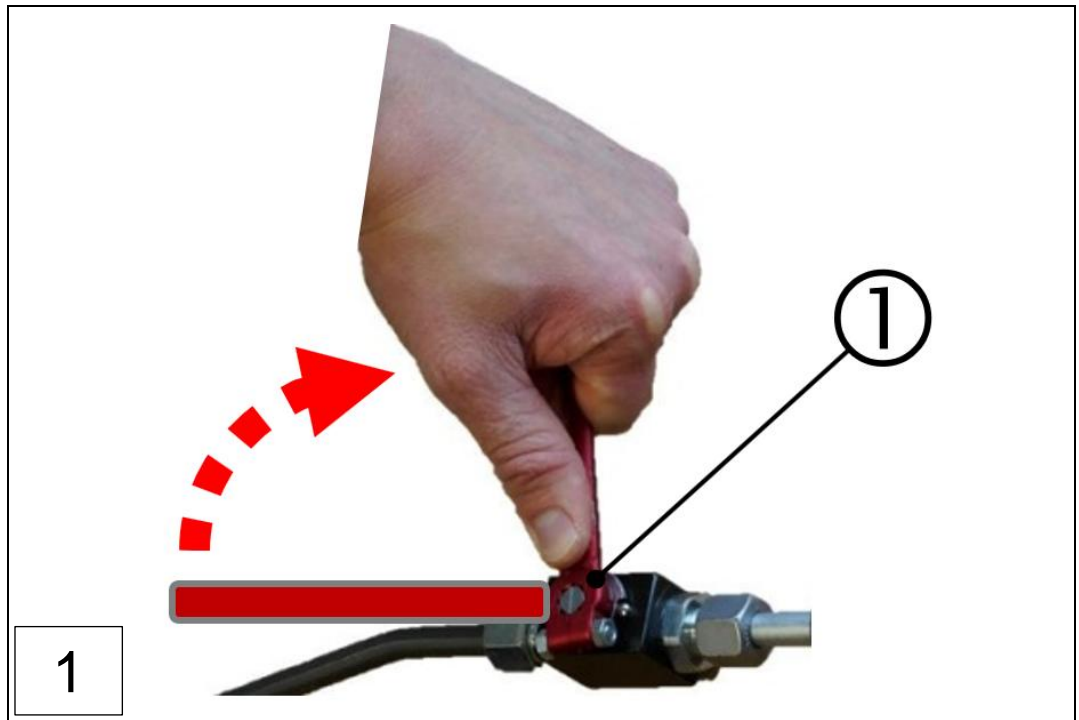

Fig.: 90 : Filter control valve, VN2020 oil mist detector

1: VN2020 measuring head

2: Filter control valve (the pressure regulator unit)

The filter control valve is replaced according to the following steps:



1: Shutoff lever valve (close)

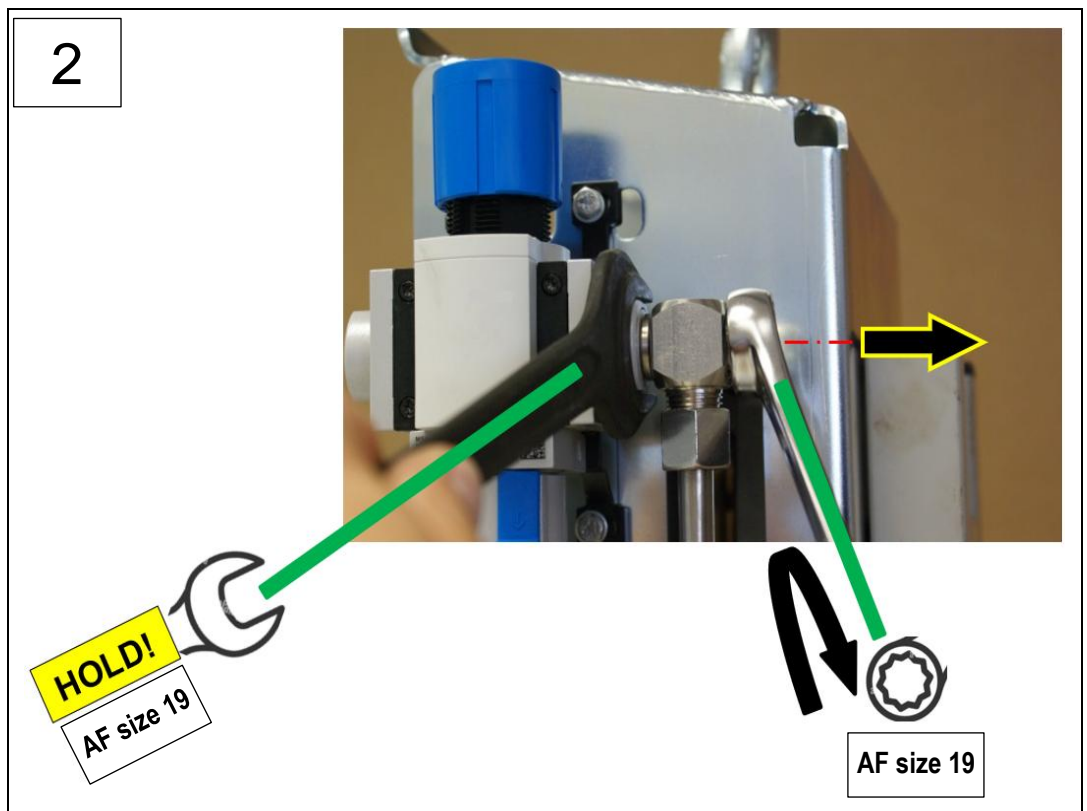

► Loosen the screw connection (right).

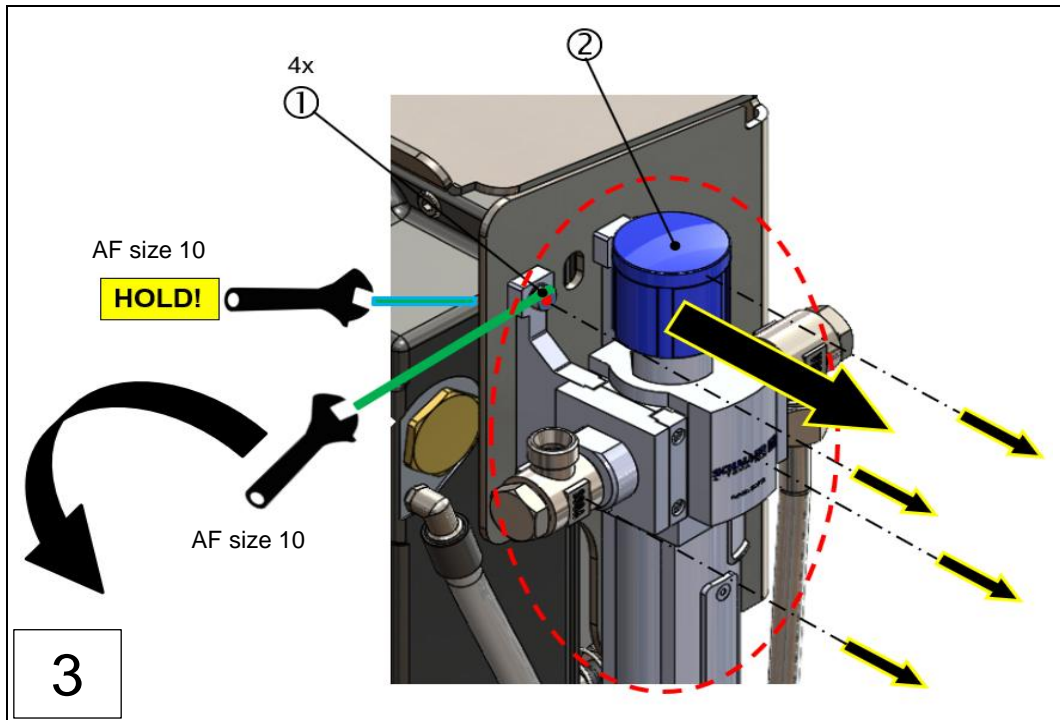

1: 4x fixing screws, full set (old)

2: Filter control valve (old)

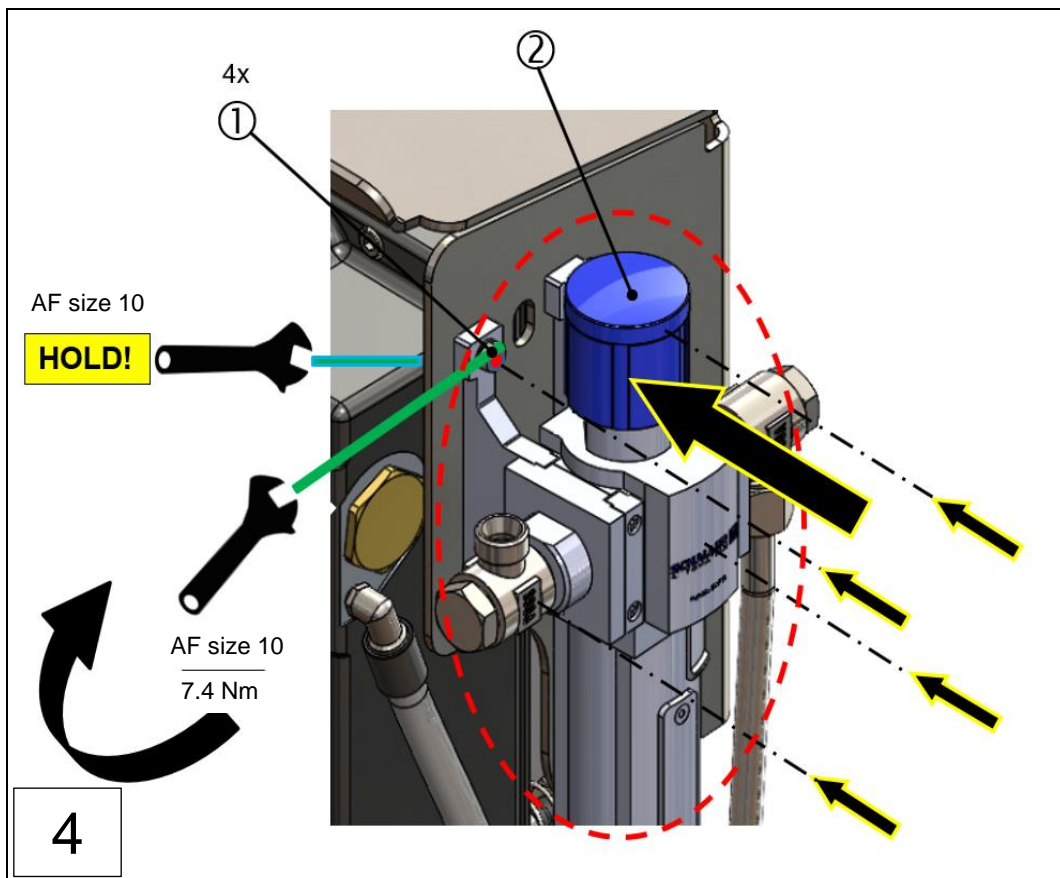

1: 4x fixing screws, full set (new)

2: Filter control valve (new)

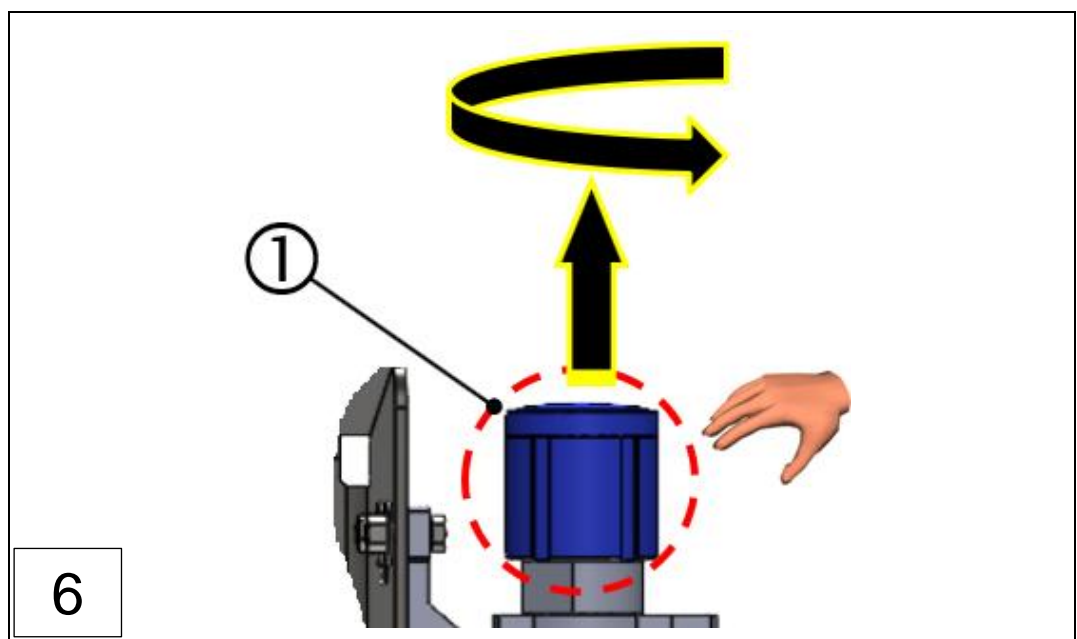
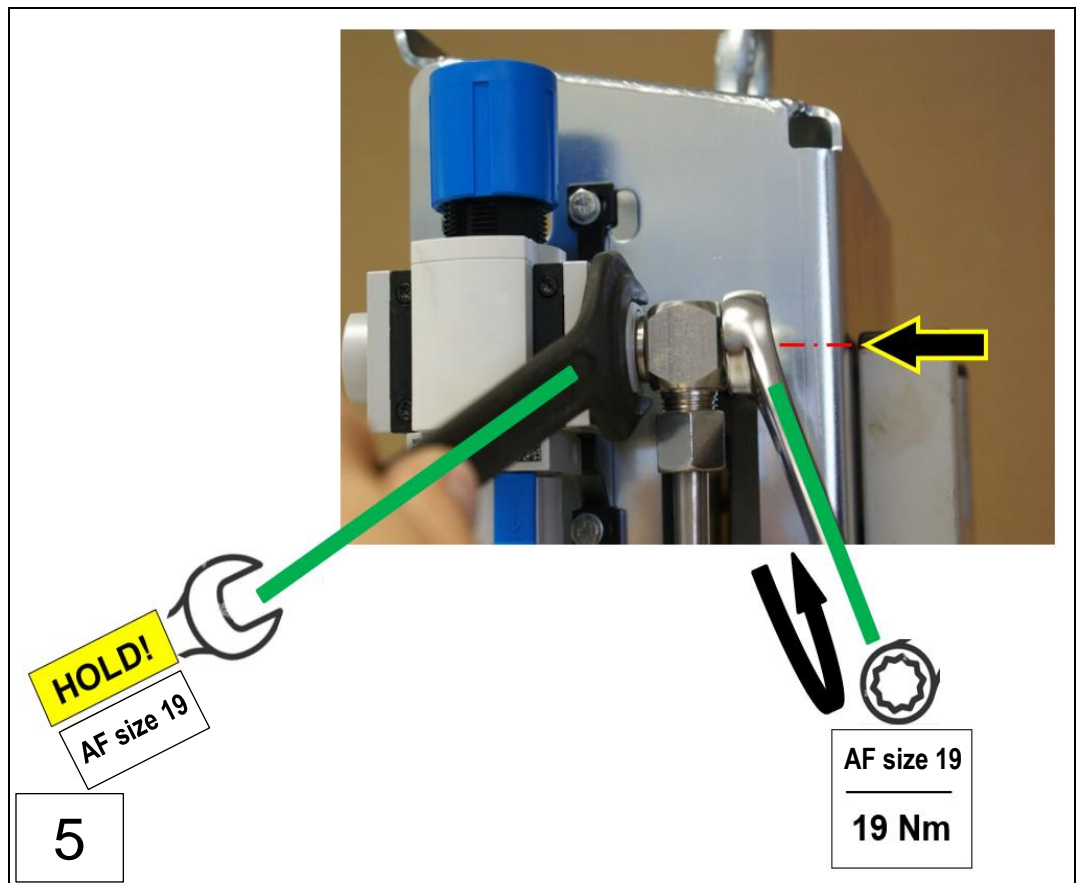

1: Adjusting cap

NOTE

Checking the supply pressure on the oil mist detector

- ▶ After completing installation step 7, the supply pressure on the VN2020 measuring head has to be checked again and readjusted if necessary.
- ▶ See Section 6.5.3 → Section 6.5.3 *Setting the negative pressure at the measuring head of the VN2020/VN2020 EX*



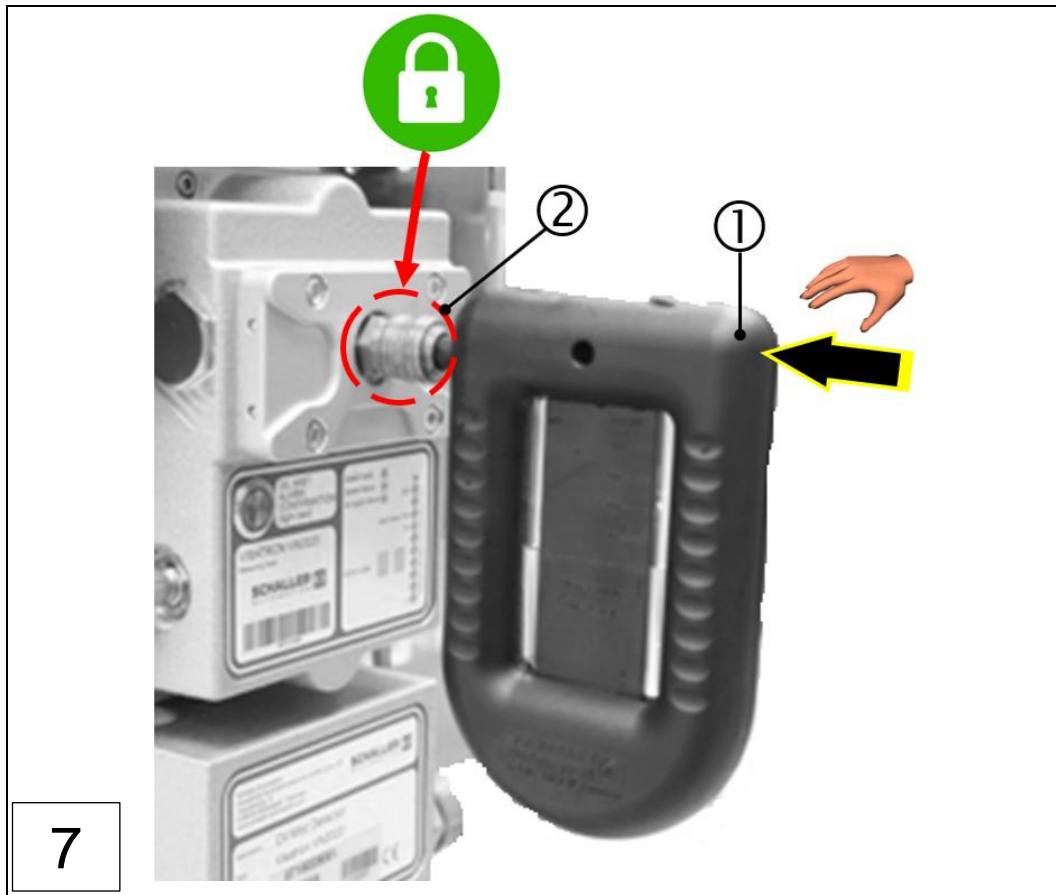

1: U-tube manometer

2: Quick-release coupling

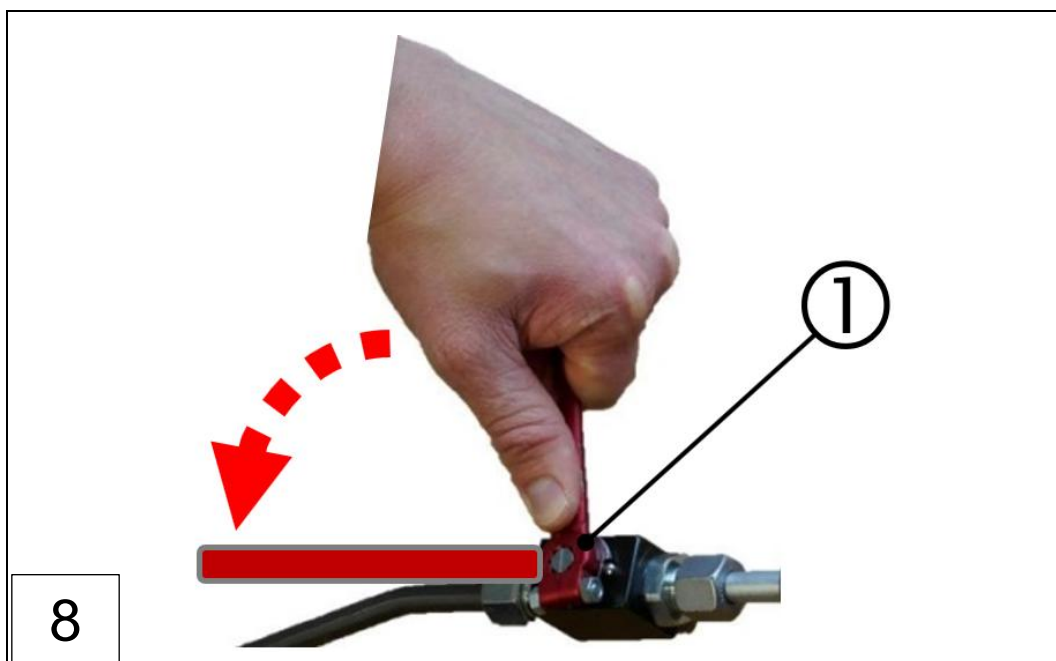

Fig.: 91 : Replacing the filter control valve (steps 1-8)

1: Shutoff lever valve (open)

► **The filter control valve has been successfully replaced and the device is ready for operation!**

9.3.8 Replacing the connecting hose on the VN2020/VN2020 EX

If the connecting hose that connects the venturi injector to the measuring head has a defect or malfunction, it has to be replaced. The connecting hose is a spare part and can be ordered separately from Schaller Automation as follows:

- ▶ **Connecting hose: 290025**



NOTE

Maintenance work on the oil mist detector

- ▶ Observe the safety instructions in Section 9. → *Section 9 Maintenance and repair*



DANGER

- ▶ The connecting hose may only be replaced with the engine switched off.
- ▶ The compressed air supply must be switched off before starting maintenance and repair work.



NOTE

Personal protective equipment

Operating the device or working on the device without protective equipment may result in serious injury. For the workplace PPE, the following protective equipment must be used:



- ▶ Safety glasses in accordance with DIN EN 166 or DIN EN 170.
- ▶ Safety helmet in accordance with DIN EN 397 or DIN EN 50365.
- ▶ ESD safety shoes according to ESD standard DIN EN 61340-5-1.

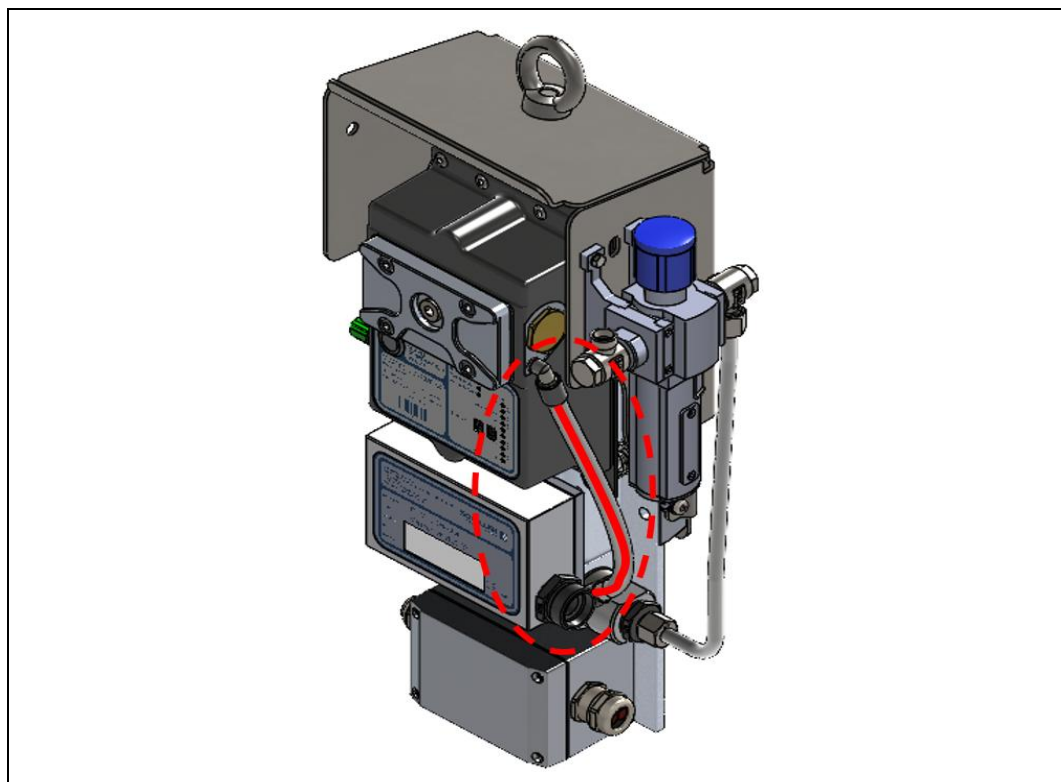
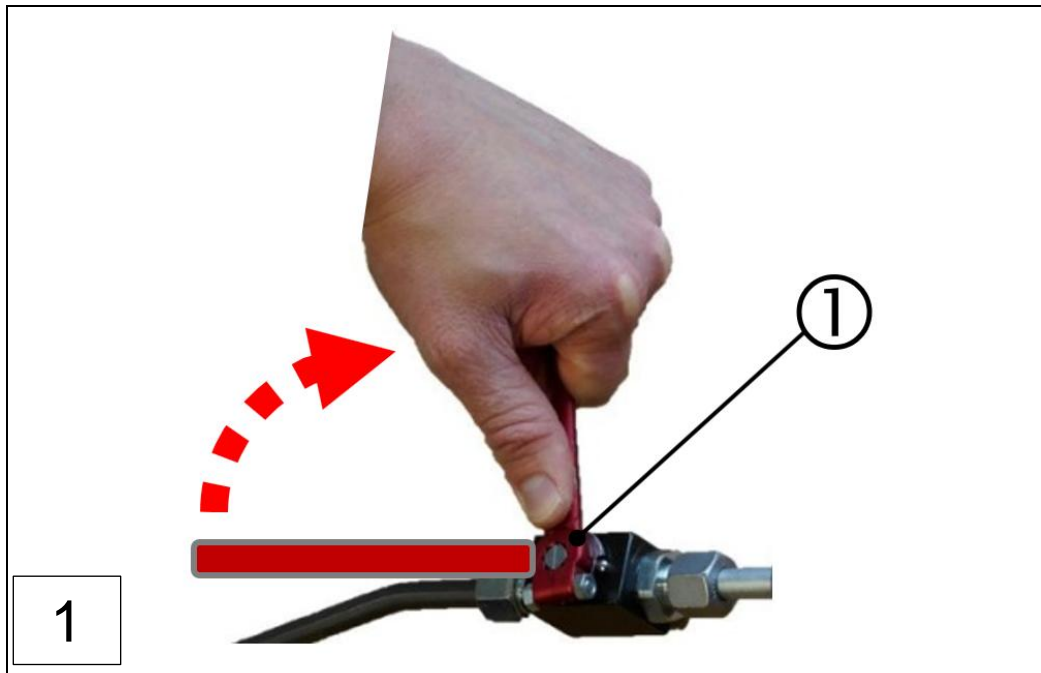
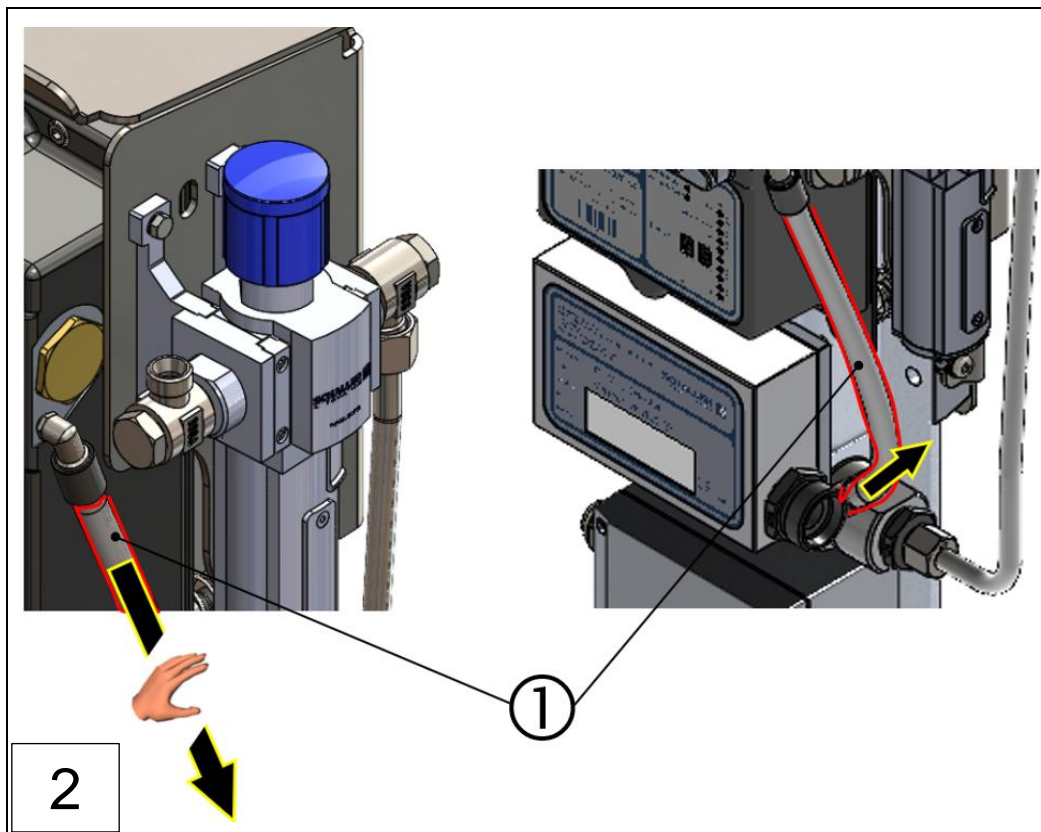

Fig.: 92 : Connecting hose, VN2020 oil mist detector

The connecting hose, is replaced according to the following steps:



1: Shutoff lever valve (close)



1: Connecting hose (old)

- ▶ Pull off the connecting hose to be replaced (①) on the right side of the measuring head and on the venturi injector.
- ▶ Insert the new connecting hose back into the two push-in fittings as far as it will go, as per the figure below.

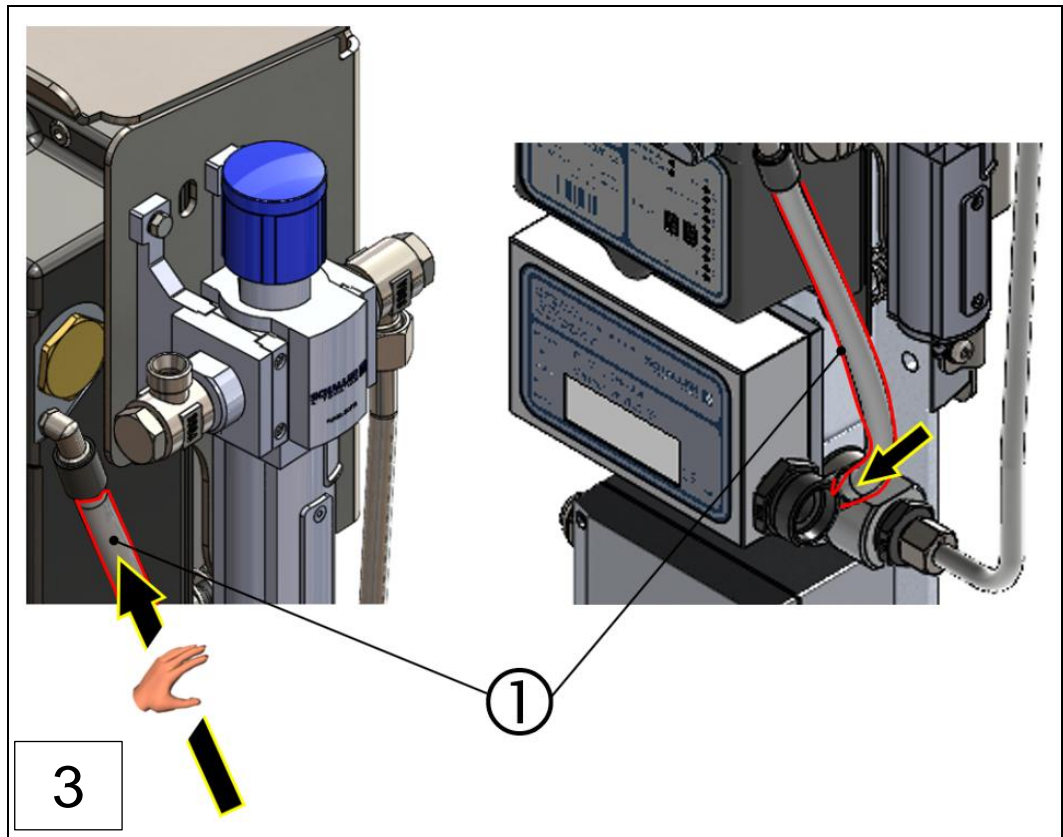

1: Connecting hose (new)

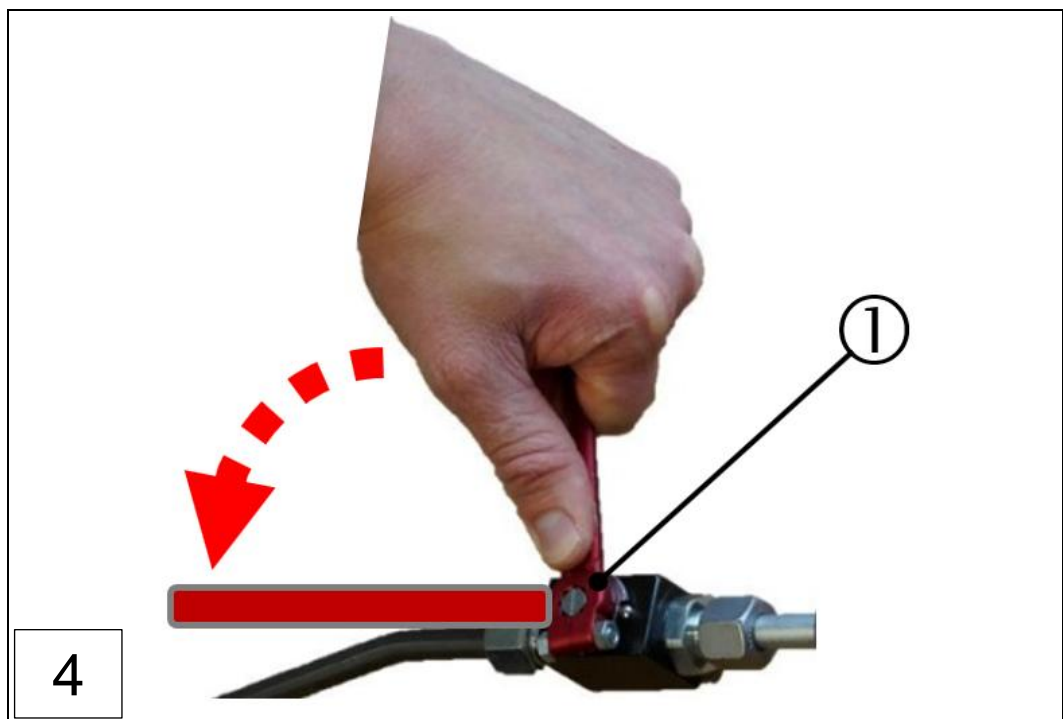

Fig.: 93 : Replacing the connecting hose (steps 1-4)

1: Shutoff lever valve (open)

- **The connecting hose has been successfully replaced and the device is ready for operation!**

9.4 Repair by Schaller Automation

If your oil mist detector is defective or malfunctions, please contact Schaller Automation or an authorised service partner immediately.

See Section 12 (⇒ *Section 12 Contact*) in this manual for suitable partners or go to <https://schaller-automation.com/en/partners/>.











9.5 Taking out of service and disassembly

The oil mist detector is taken out of service in the reverse order to being put into service.
⇒ *Section 6.5 Starting up for the first time*

9.6 Starting up again

The oil mist detector is started up again in the same way as it is started for the first time.
⇒ *Section 6.5 Starting up for the first time*

10 Error diagnosis and troubleshooting

	 WARNING
	<p>Risk of oil mist explosion</p> <p>Failure to comply with the safety instructions may result in major damage to property or the environment and in serious injury or death.</p> <ul style="list-style-type: none"> ▶ Start by familiarising yourself with the basic safety instructions for working with the oil mist detector. → <i>Section 2.4 Basic safety instructions</i> ▶ If the oil mist detector is operated in explosion-proof areas, the relevant safety instructions must be observed. → <i>Section 2.4.1 Safety instructions for potentially explosive atmospheres</i>
	
	 CAUTION
	<p>Working safely and correctly with the oil mist detector</p> <ul style="list-style-type: none"> ▶ Read this operating manual and other documents that accompany the product carefully and keep them in a suitable place for future reference.
	 NOTE
	<p>Personal protective equipment</p> <p>Working on the device <u>without</u> protective equipment may result in serious injury. For the workplace PPE, the following protective equipment must be used:</p> <ul style="list-style-type: none"> ▶ DIN EN 388:2016 Protective gloves against mechanical risks, 2341X, and DIN EN 407:2004 Protective gloves against thermal risks, X1XXXX. ▶ Safety glasses in accordance with DIN EN 166 or DIN EN 170. ▶ Safety helmet in accordance with DIN EN 397 or DIN EN 50365. ▶ ESD safety shoes according to ESD standard DIN EN 61340-5-1.

10.1 Behaviour of the oil mist detector in the event of a fault

The oil mist detector is declared by the Classification Societies to be the primary safety system. In the event of a device defect, the operator must correct the defect as quickly as possible. The easiest way to do this is to replace the faulty measuring head.

→ *Section 13.4 Upgrade Spare parts*

If an internal device or system error occurs, the “Error code” display (①) uses the diagnostic system to display the error code on the two-digit LED numerical display (②), as shown in the figure below.

The **green** “System ready” LED goes off at the same time.

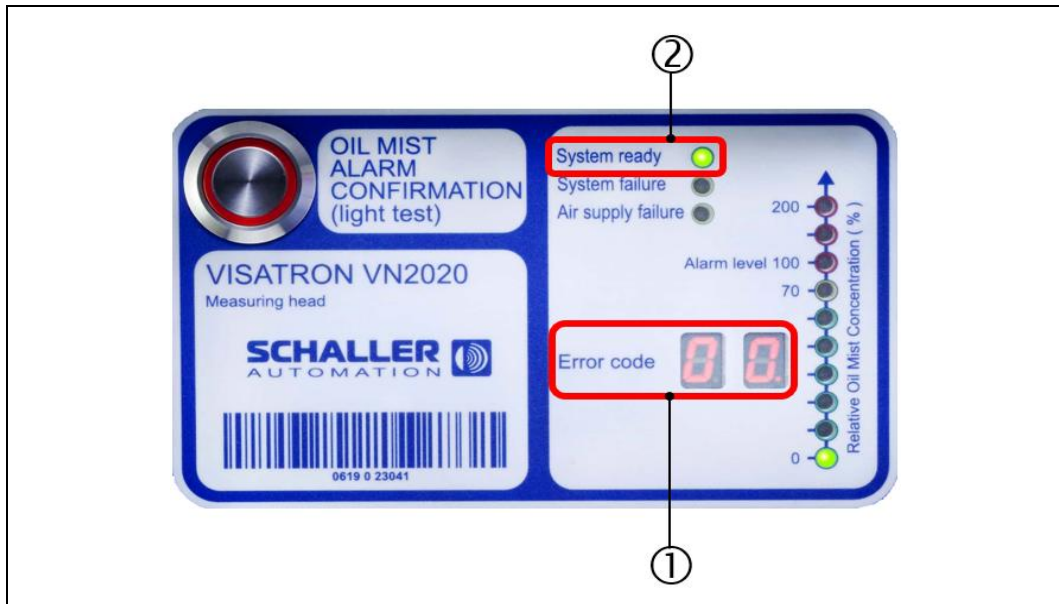





Fig.: 94 : VN200 measuring head: “System or device error” status indicator

1: “Error code” display

2: “System status” display

10.1.1 Defect in the measuring head

! WARNING







Replacing a defective measuring head

Failure to comply with the safety instructions may result in major damage to property or the environment and in serious injury or death.

- ▶ Start by familiarising yourself with the basic safety instructions for working with the oil mist detector. ⇒ *Section 2.4 Basic safety instructions*
- ▶ If the oil mist detector is operated in explosion-proof areas, the relevant safety instructions must be observed. ⇒ *Section 2.4.1 Safety instructions for potentially explosive atmospheres*

! DANGER

Hazards in explosion-proof areas, when replacing a defective measuring head

Further safety instructions must be followed for SCHALLER products intended for use in potentially explosive atmospheres, as follows:

- ▶ For an installed VN200 EX oil mist detector, e.g. on dual-fuel engines, the measuring head must be disassembled and assembled in the shortest possible time, as explosive atmosphere can escape into a non-explosion-proof area, i.e. outside the engine.
- ▶ Disassembly and assembly are only allowed with the engine switched off!

There is a risk of serious injury, including death, from explosion in the crankcase as a result of incorrect assembly or installation.

- ▶ The system must be de-energised first! The compressed air supply to the oil mist detector must also be switched off first.
- ▶ Before starting assembly, the housing of the VISATRON® VN2020/VN2020 EX oil mist detector must be earthed.

10.2 Error diagnosis and troubleshooting



NOTE

Restricted function in the event of an error

- ▶ If an internal device error or system error occurs, the diagnostic system displays the error code via the 2-LED numerical display.
- ▶ If a device or system error occurs, the “System ready” LED goes off and any oil mist is **not** detected in this mode of operation.

The displayed errors can be corrected by the customer or alternatively by an authorised Schaller service partner. In this case, contact service at Schaller Automation Industrielle Automationstechnik GmbH & Co KG. ⇒ *Section 12 Contact*

The error codes (on the display on the Remote Indicator II) and how to correct them are listed below in order of priority. The specified work steps must be carried out one after the other, if the previous work step in each case has not cancelled the error code.

10.2.1 Error diagnosis

Error code	Error description	Ready for operation	“System failure” LED
None	All LEDs are off/no output	No	Off
00	Oil mist detector in operation	Yes	Off
02	Internal error	No	On
03	Internal error	No	On
04	Internal error	No	On
06	Supply voltage not within allowed range	No	On
07	Internal error	No	On
08	Electronics temperature too high (> 85 °C)	No	On
09	Electronics temperature too low (< 0 °C)	No	On
12	Battery voltage too low	Yes	Off

Error code	Error description	Ready for operation	“System failure” LED
14	Supply pressure too low	No	On
15	Optical sensor very dirty– cleaning must be carried out	No	On
16	Internal error	No	On
30	Internal error	No	On
33	Supply pressure too high	No	On
34	Internal error	No	On
35	Internal error	No	On

Table 15 : Error diagnosis

10.2.2 Troubleshooting

Error code	Description	Type of fault/ possible causes	Solution
No display	Device switched off	All LEDs are off/no output <ul style="list-style-type: none"> ▪ No power supply ▪ Fuse in measuring head is defective/missing 	1. Check the power supply 2. Check the fuse in the measuring head and replace if necessary (Section 9.3.2) 3. Replace measuring head (Section 9.3.1) Optional: Contact service partner (Section 12)
00	Device in operation	Device is ready for operation	No solution required
02	Internal error	Device is not ready for operation <ul style="list-style-type: none"> ▪ Measuring head defective 	1. Replace measuring head (Section 9.3.1) Optional: Contact service partner (Section 12)
03	Internal error	Device is not ready for operation <ul style="list-style-type: none"> ▪ Measuring head defective 	2. Replace measuring head (Section 9.3.1) Optional: Contact service partner (Section 12)
04	Internal error	Device is not ready for operation <ul style="list-style-type: none"> ▪ Measuring head defective 	1. Replace measuring head (Section 9.3.1) Optional: Contact service partner (Section 12)
06	Supply voltage not within allowed range	Device is not ready for operation	1. Check the power supply 2. Replace measuring head (Section 9.3.1) Optional: Contact service partner (Section 12)
07	Internal error	Device is not ready for operation <ul style="list-style-type: none"> ▪ Measuring head defective 	1. Replace measuring head (Section 9.3.1) Optional: Contact service partner (Section 12)
08	Electronics temperature too high (> 85 °C)	Device is not ready for operation <ul style="list-style-type: none"> ▪ Ambient temperature too high 	1. Remove or relocate objects nearby emitting heat 2. Install metallic heat shields to shield again heat radiation

Error code	Description	Type of fault/ possible causes	Solution
09	Electronics temperature too low (< -0 °C)	Device is not ready for operation ▪ Ambient temperature too low	1. Bring within allowed range of operating temperature (Section 3.4.4)
12	Battery voltage too low	Device ready for operation, "System ready" LED is on	1. Contact service partner (Section 12)
14	Supply pressure too low	Device is not ready for operation ▪ Negative pressure not set correctly	1. Adjust negative pressure (Section 6.5.3) 2. Replace filter for filter control valve (Section 9.1.3) 3. Replace measuring head (Section 9.3.1)
15	Optical sensor very dirty– cleaning must be carried out	Device is not ready for operation ▪ Light path components are dirty	1. Clean the light path (Section 9.1.2) 2. Replace measuring head (Section 9.3.1) <u>Optional:</u> Contact service partner (Section 12)
16	Internal error	Device is not ready for operation ▪ Measuring head defective	1. Replace measuring head (Section 9.3.1) <u>Optional:</u> Contact service partner (Section 12)
30	Internal error	Device is not ready for operation ▪ Measuring head defective	1. Replace measuring head (Section 9.3.1) <u>Optional:</u> Contact service partner (Section 12)
33	Supply pressure too high	Device is not ready for operation ▪ Negative pressure not set correctly	1. Adjust negative pressure (Section 6.5.3) 2. Replace filter for filter control valve (Section 9.1.3) 3. Replace measuring head (Section 9.3.1)
34	Internal error	Device is not ready for operation ▪ Measuring head defective	1. Replace measuring head (Section 9.3.1) <u>Optional:</u> Contact service partner (Section 12)
35	Internal error	Device is not ready for operation ▪ Measuring head defective	1. Replace measuring head (Section 9.3.1) <u>Optional:</u> Contact service partner (Section 12)

Table 16 : Troubleshooting

11 Final shutdown and disposal



WARNING

Warning – risk of oil mist explosion when shutting down the oil mist detector

- ▶ For final shutdown and disposal, observe the safety instructions for handling the oil mist detector. ⇒ *Section 2.4 Basic safety instructions*
- ▶ If the oil mist detector is operated in explosion-proof areas, the additional safety instructions must be observed. ⇒ *Section 2.4.1 Safety instructions for potentially explosive atmospheres*
- ▶ Do not dispose of product in fire.
- ▶ Do not open the product by force.

11.1 Disposal



NOTE

Disposal of the product

- ▶ This product must not be disposed of as residential waste. It is therefore marked with the symbol on the left.
- ▶ Schaller Automation takes back this product free of charge. Information about this is available from the national sales organisations and Schaller Automation. ⇒ *Section 12 Contact*

11.2 Final shutdown

Final shutdown of the oil mist detector is carried out according to Section 9.5 of this manual. ⇒ *Section 9.5 Taking out of service and disassembly*

12 Contact

You can use the following contact details to contact customer service at Schaller Automation Industrielle Automationstechnik GmbH & Co. KG:

SCHALLER Automation (Headquarters)
Industrielle Automationstechnik GmbH & Co. KG
Industriering 14
66440 Blieskastel, Germany
Phone: +49 6842 508 0
Fax: +49 6842 508 260
Email: info@schaller.de
Website: www.schaller-automation.com

Schaller Automation LP
811 Shotgun Road
Sunrise, FL 33326
United States of America
Phone: +1 954 794 1950
Mobile: +1 561 289 1495
Fax: +1 954 794 1951
Email: info@schalleramerica.com

Schaller Automation Pte Ltd.
114 Lavender Street
#09-93 CT Hub 2
Singapore 338729
Phone: +65 6643 5151
Mobile: +65 9788 7550
Fax: +65 6643 5150
Email: info@schallersingapore.com
Website: www.schaller.sg

Schaller Automation – China
Room 401, Juyang Mansion No. 1200
Pudong Avenue,
Shanghai 200135, P.R.China
Phone: +86 21 5093 7566
Mobile: +86 1390 1890 736
Fax: +86 21 5093 7556
Email: info@schallerchina.cn



You can also find all our certified partners on our homepage at:

<https://schaller-automation.com/partner/>

13 Spare parts and accessories, VN2020/VN2020 EX

WARNING



Using unapproved spare parts may affect the safety of the installation. Original spare parts are necessary for the device to operate correctly and are designed for your safety. Using other parts may exclude liability for the consequences.

- ▶ Only use original spare parts from Schaller Automation!

13.1 Emergency Spare parts (kept in stock), VN2020

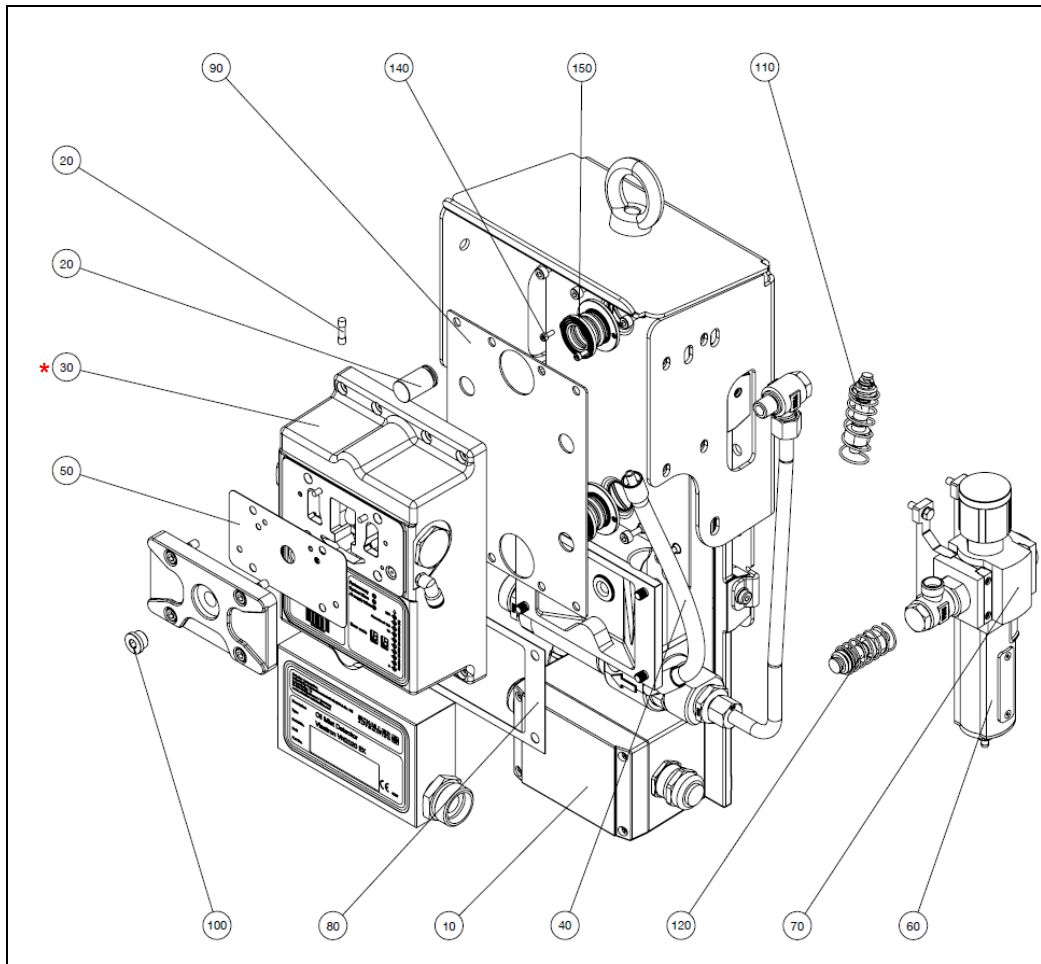

Fig.: 95 : Overview of the positions of spare parts (kept in stock) for the VISATRON® VN2020

NOTE



Spare parts kept in stock for emergencies

- ▶ The following table is for a VISATRON® VN2020 device.

Item	Part number	Description	Quantity	Kit number
10	290043	Spare parts kit for terminal box	1	-
20	(270045)	Lithium battery with diode	1	155004
30*	-	*) See Section 13.4	-	-
40	290025	Spare parts kit for connecting hose	1	-
50	(356952)	Seal for inspection cover	1	155004/155006
60	(366717)	Filter cartridge	1	155004/155006
70	273456	Filter control valve (flow left to right)	1	-
	273461	Filter control valve (flow right to left)	1	-
80	(356950)	Seal for connecting box	1	155004/155006
90	(356951)	Seal for mounting plate	1	155004/155006
100	(366604)	Screw plug	1	155004
110	(200211)	Top spring system	2	155004
120	(200212)	Bottom spring system	2	155004
130	436513	Fuse	1	-
140	(480065)	Socket head cap screw ISO 4762-M3 x 8-A2-50	4	155004
150	(2001310)	Bellows	2	155004

Table 17 : Recommended spare parts (kept in stock) for emergencies, VISATRON® VN2020

13.1.1 Cleaning kit for VN2020/VN2020 EX

The cleaning kit is used for both the VN2020 and VN2020 EX and can be ordered separately from Schaller Automation as follows:

► **Cleaning kit: 151482**



Fig.: 96 : Cleaning kit for VISATRON® VN2020/VN2020 EX

Item	Part number	Description	Quantity	Kit number
1	(190003)	Injector cleaning needle*	1	151482
2	(452176)	Cotton stick	20	151482
3	(270090)	10ml bottle with cleaning agent	1	151482

Table 18 : Cleaning kit for VISATRON® VN2020/VN2020 EX

(*): Do not use for VN2020/VN2020 EX!

13.1.2 Service box for VN2020/VN2020 EX

The service box is used for both the VN2020 and VN2020 EX and can be ordered separately from Schaller Automation as follows:



Part number	Description	Unit	Quantity	Price info
151906	<p>Service box for VN2020/VN2020 EX</p> <p>The service box contains all the tools and parts required to maintain and check the oil mist detector. The service box includes a contents list and manual on CD or DVD.</p> 	Pcs	1	On request!
272059	<p>MSA smoke tubes for service pack (6 pcs)</p> <p>Refill pack for service box (151906) Content: 6 pcs</p> 	Pcs	1	On request!

Table 19 : Service box for the VISATRON® VN2020/VN2020 EX

13.2 Emergency Spare parts (kept in stock), VN2020 EX

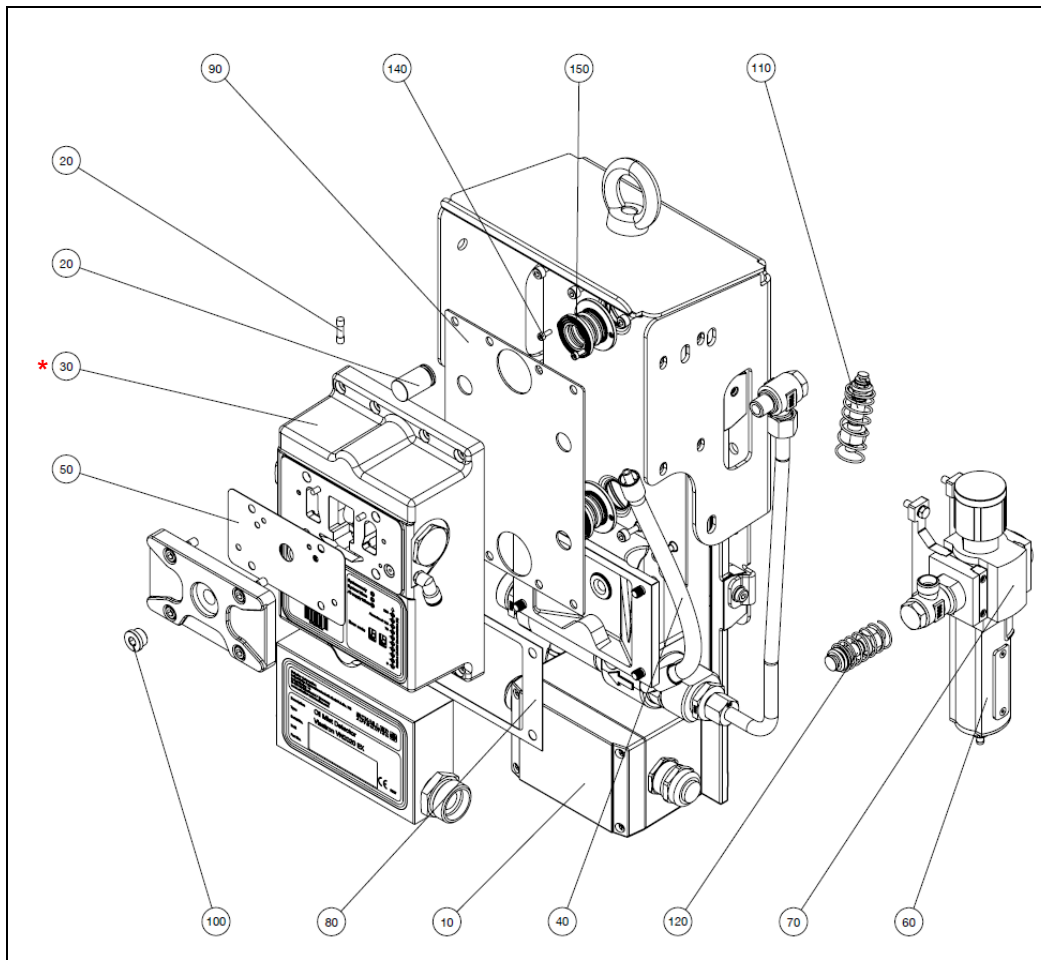

Fig.: 97 : Overview, positions of spare parts (kept in stock) for the VISATRON® VN2020 EX

NOTE



Spare parts kept in stock for emergencies

- ▶ The following table is for a VISATRON® VN2020 EX device.

Item	Part number	Description	Quantity	Kit number
10	290043	Spare parts kit for terminal box	1	-
20	(270045)	Lithium battery with diode	1	155004
30*	-	*) See Section 13.4	-	-
40	290025	Spare parts kit for connecting hose	1	-
50	(356952)	Seal for inspection cover	1	155004/155006

Item	Part number	Description	Quantity	Kit number
60	(366717)	Filter cartridge	1	155004/155006
70	273456	Filter control valve (flow left to right)	1	-
	273461	Filter control valve (flow right to left)	1	-
80	(356950)	Seal for connecting box	1	155004/155006
90	(356951)	Seal for mounting plate	1	155004/155006
100	(366604)	Screw plug	1	155004
110	(200211)	Top spring system	2	155004
120	(200212)	Bottom spring system	2	155004
130	436513	Fuse	1	-
140	(480065)	Socket head cap screw ISO 4762-M3 x 8-A2-50	4	155004
150	(2001310)	Bellows	2	155004

Table 20 : Recom. spare parts (kept in stock) for emergencies, VISATRON® VN2020 EX

13.2.1 Cleaning kit for VN2020 EX

See also Section 13.1.1 in this manual.

⇒ Section 13.1.1 Cleaning kit for VN2020/VN2020 EX

13.2.2 Service box for VN2020/VN2020 EX

See also Section 13.1.2 in this manual.

⇒ Section 13.1.2 Service box for VN2020/VN2020 EX

13.3 Maintenance Spare parts



NOTE

Spare parts kept in stock for maintenance

- ▶ The following table is for a VISATRON® VN2020/VN2020 EX device.

13.3.1 Maintenance kit (4,000/8,000/12,000 hours)

The maintenance kit is used for both the VN2020 and VN2020 EX and can be ordered separately from Schaller Automation as follows:

- ▶ **Maintenance kit: 155006**

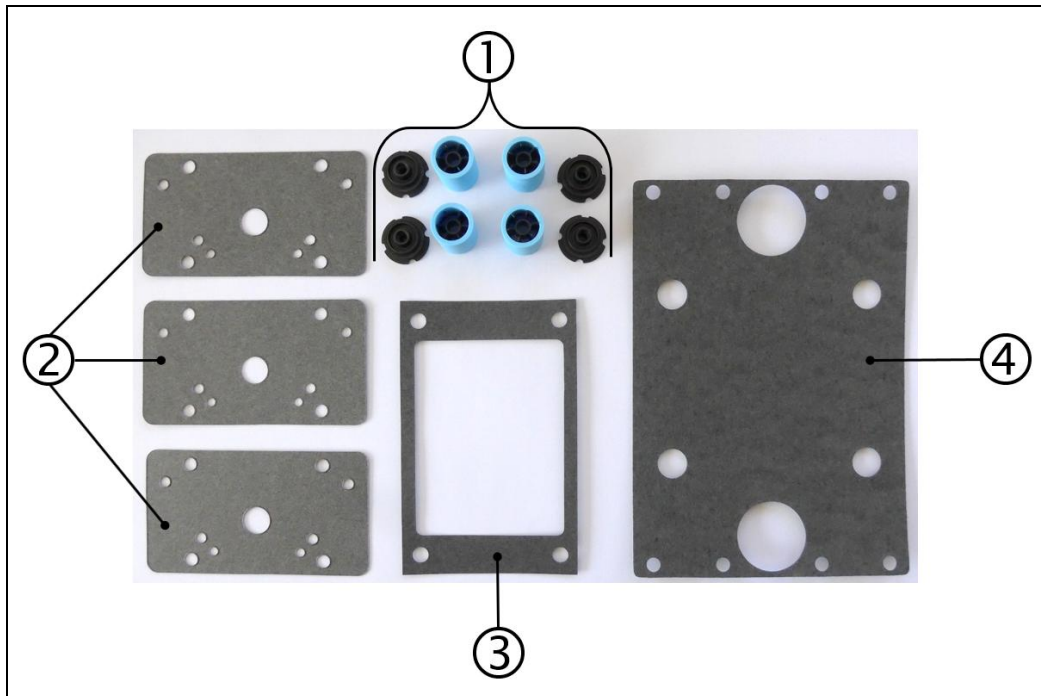

Fig.: 98 : Maintenance kit for the VISATRON® VN2020/VN2020 EX

Item	Part number	Description	Quantity	Kit number
1	(366717)	Filter cartridge	4	155006
2	(356952)	Seal for inspection cover	3	155006
3	(356950)	Seal for connecting box	1	155006
4	(356951)	Seal for mounting plate	1	155006

Table 21 : Maintenance kit for the VISATRON® VN2020/VN2020 EX

13.3.2 Service kit for VN2020 (16,000 hours/24 months)

The service kit is used for both the VN2020 and VN2020 EX and can be ordered separately from Schaller Automation as follows:

- ▶ **Service kit: 155004**



NOTE

Maintenance work on the oil mist detector

- ▶ Observe the safety instructions in Section 9 → *Section 9 Maintenance and repair*

Early loss of warranty

- ▶ The service kit and the associated service work on the oil mist detector may only be carried out by an authorised Schaller service partner or by personnel trained for this purpose.

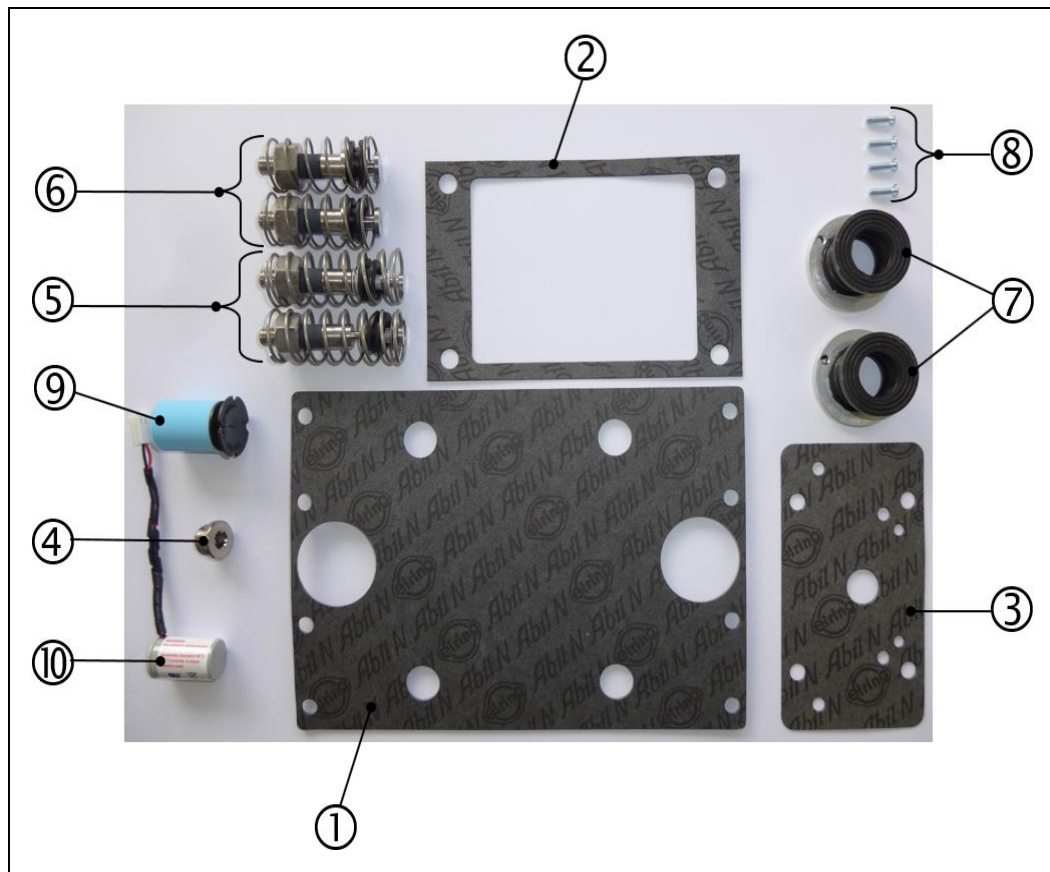

Fig.: 99 : Service kit for the VISATRON® VN2020/VN2020 EX

Item	Part number	Description	Quantity	Kit number
1	(356951)	Seal for mounting plate	1	155004
2	(356950)	Seal for connecting box	1	155004
3	(356952)	Seal for inspection cover	1	155004
4	(366604)	Screw plug	1	155004
5	(200211)	Top spring system	2	155004
6	(200212)	Bottom spring system	2	155004
7	(2001310)	Bellows	2	155004
8	(480065)	Socket head cap screw ISO 4762-M3 x 8-A2-50	4	155004
9	(366717)	Filter cartridge	1	155004
10	(270045)	Lithium battery with diode	1	155004

Table 22 : Service kit for the VISATRON[®] VN2020/VN2020 EX

13.4 Upgrade Spare parts

The following can be ordered from Schaller Automation for updating devices:



NOTE

Spare parts kept in stock for maintenance

- ▶ The following table is for a VISATRON® VN2020/VN2020 EX device.

Item	Part number	Description	Quantity	Kit number
1	290051*	Spare parts kit for the measuring head, VN2020 (5-port CAT)	1	5-port version CAT
2	290056*	Spare parts kit for the measuring head, VN2020 (MAN)	1	MAN version
3	290057*	Spare parts kit for the measuring head, VN2020	1	CAT / MaK / Wärtsilä / RRB
4	290058*	Spare parts kit for the measuring head, VN2020 EX	1	CAT / MaK / Wärtsilä / RRB EX
5	290082*	Spare parts kit for the measuring head, VN2020 EX (MAN)	1	MAN EX

Table 23 : Device update (measuring head) for the VISATRON® VN2020 / VN2020 EX

(*): Please complete the form first to provide your device data when requesting the “Spare parts kit for measuring head” item and send it to Schaller Automation or to an authorised service partner from Section 12 of this manual. → *Section 12 Contact*

Alternatively, visit our homepage to find your nearest service partner.

<https://schaller-automation.com/partner/>

13.5 Accessories

Part number	Description	Unit	Quantity	Price info
151780	<p>Smoke test box for VISATRON® devices</p> <p>The smoke test box contains all the tools and parts required to maintain and check the oil mist detector.</p> 	Pcs	1	On request!
270532	<p>U-tube manometer for VISATRON® devices</p> <p>U-tube manometer, including accessories and list of contents, for setting the negative pressure on VISATRON® devices.</p> 	Pcs	1	On request!



Part number	Description	Unit	Quantity	Price info
151800	<p>Differential pressure gauge for VISATRON® devices</p> <p>Differential pressure gauge including accessories, for measuring differential pressures from 0 to 100 hPa on VISATRON® devices.</p> 	Pcs	1	On request!
451209	<p>Smoke fluid for VISATRON® devices</p> <p>Smoke fluid for the Schaller smoke generator, for performing smoke tests</p>  <p>(Similar to shown)</p>	Pcs	1	On request!

Table 24 : List of accessories for VISATRON® VN2020/VN2020 EX

14 List of figures

Fig.: 1 :	Name plate, VISATRON® VN2020 measuring head	23
Fig.: 2 :	Name plate, VISATRON® VN2020 measuring head	24
Fig.: 3 :	Name plate, VISATRON® VN2020 EX measuring head	24
Fig.: 4 :	Name plate, VISATRON® VN2020 EX measuring head	25
Fig.: 5 :	Name plate, VISATRON® VN2020 connecting box.....	25
Fig.: 6 :	Name plate, VISATRON® VN2020 connecting box.....	26
Fig.: 7 :	Name plate, VISATRON® VN2020 EX connecting box	26
Fig.: 8 :	Name plate, VISATRON® VN2020 EX connecting box	27
Fig.: 9 :	Mechanical dimensions, VISATRON® VN2020/VN2020 EX	28
Fig.: 10 :	Component overview, standard drainage, VISATRON® VN2020	32
Fig.: 11 :	Component overview, drainage concept with siphon block, VISATRON® VN2020	33
Fig.: 12 :	Component overview for the VISATRON® VN2020 oil mist detector	34
Fig.: 13 :	Component overview for the VISATRON® VN2020 EX oil mist detector	35
Fig.: 14 :	Bracket for the VN2020 series (example variant).....	37
Fig.: 15 :	Pipe with screw fitting, installation kit for VN2020 series	38
Fig.: 16 :	Engine wall connection (EWC) for the VN2020 series	38
Fig.: 17 :	Siphon block for the VN2020 series	39
Fig.: 18 :	Flexible hose line for the VN2020 series	39
Fig.: 19 :	Pipe siphon, VN2020 series	40
Fig.: 20 :	Functional principle of oil drainage via pipe siphon, VN2020	40
Fig.: 21 :	Remote monitoring system (Remote Indicator II) for VISATRON® systems (optional)	41
Fig.: 22 :	Controls and indicators, VN2020	43
Fig.: 23 :	Controls and indicators, VN2020 EX	43
Fig.: 24 :	Installing VN2020 with bracket and protective cover.....	50
Fig.: 25 :	Installing VN2020 without bracket and with protective cover (rear view)	52
Fig.: 26 :	ROMOB M8, installed	52
Fig.: 27 :	Engine wall connection (EWC)	53
Fig.: 28 :	Recommended inst. for the engine wall connection (view from the crankshaft end)	54
Fig.: 29 :	Installing the engine wall connection for the VN2020 (installation steps 1-9)	59
Fig.: 30 :	Siphon block assembly	59
Fig.: 31 :	Installing and starting up the siphon block assembly (installation steps 1-11).....	66
Fig.: 32 :	Pipe siphon assembly.....	66
Fig.: 33 :	Installing and starting up the pipe siphon assembly (installation steps 1-5)	70
Fig.: 34 :	Pipe with screw fitting, VN2020 series	71
Fig.: 35 :	Position of the recirculation line on the VN2020.....	72
Fig.: 36 :	Installing the recirculation line on the VN2020 (steps 1-4)	74
Fig.: 37 :	Flexible hose line for the VN2020 series	75
Fig.: 38 :	Remote Indicator II (optional)	76
Fig.: 39 :	Dimensions of installation space for Remote Indicator II	77
Fig.: 40 :	Installing Remote Indicator II (installation steps 1-4).....	78
Fig.: 41 :	Connection diagram for VN2020	80
Fig.: 42 :	Connection board, VN2020 terminal box.....	81
Fig.: 43 :	VN2020 terminal box: Removing the cover (installation steps 1-2)	82
Fig.: 44 :	VN2020 terminal box: Configuration of the wire break resistors	83
Fig.: 45 :	VN2020 terminal box: Inserting the wire break resistors (installation steps 1-3)	84
Fig.: 46 :	Terminal assignment diagram, terminal box for VN2020	85
Fig.: 47 :	Electrical connection terminal box (example installation), VN2020	85
Fig.: 48 :	Recommended electrical installation, terminal box for VN2020	86
Fig.: 49 :	Establishing the power and relay supply (example installation; installation steps 1-4).....	88
Fig.: 50 :	Connecting the Remote Indicator II to terminal box (example inst.; install. steps 1-2)	89

Fig.: 51 :	Connection board for VN2020 measuring head.....	90
Fig.: 52 :	Remote Indicator II (optional); installing contacts	90
Fig.: 53 :	Closing the terminal box for VN2020	91
Fig.: 54 :	Position and installation, earth connection and protective cover for VN2020	92
Fig.: 55 :	Installing the earth connection, VN2020	92
Fig.: 56 :	“System ready” indicator on the VN2020/VN2020 EX measuring head	95
Fig.: 57 :	Setting the negative pressure on the VN2020/VN2020 EX measuring head (steps 1-6) .	98
Fig.: 58 :	Screwing in the screw plug on the measuring head of the VN2020/VN2020 EX	100
Fig.: 59 :	Setting the sensitivity.....	101
Fig.: 60 :	Function test for starting up for the first time, VN2020/VN2020 EX.....	103
Fig.: 61 :	Schaller smoke generator, VN2020/VN2020 EX	105
Fig.: 62 :	Smoke generator with factory test, VN2020/VN2020 EX.....	105
Fig.: 63 :	Function test for starting up for the first time, VN2020/VN2020 EX.....	106
Fig.: 64 :	Factory test with smoke generator (steps 1-3).....	108
Fig.: 65 :	Measuring head for VN2020, rear view, USB port	109
Fig.: 66 :	Removing the VN2020 measuring head (installation steps 1-2).....	111
Fig.: 67 :	Establishing the USB connection between the VN2020 measuring head and PC	111
Fig.: 68 :	Installing the VN2020 measuring head	112
Fig.: 69 :	VN2020 measuring head: Display in normal operation.....	115
Fig.: 70 :	VN2020 measuring head: LED check (light test)	116
Fig.: 71 :	VN2020 measuring head: “Pre-alarm” status indicator at 70% OMC	117
Fig.: 72 :	VN2020 measuring head: “Alarm” status indicator at 100% OMC.....	118
Fig.: 73 :	VN2020 measuring head: Confirming an oil mist alarm.....	119
Fig.: 74 :	“Sensor cleaning” status display, VN2020	124
Fig.: 75 :	Cleaning the light path of the VN2020 (steps 1-8)	128
Fig.: 76 :	Pressure regulator unit, VN2020 oil mist detector.....	129
Fig.: 77 :	Replacing the air filter element on the pressure regulator unit	130
Fig.: 78 :	Replacing the air filter element on the pressure regulator unit (steps 1-10)	133
Fig.: 79 :	Smoke tube with hand pump (assembled) from Smoke Test Box (151780)	134
Fig.: 80 :	Function test with test mist (steps 1-4).....	136
Fig.: 81 :	Connecting box, VN2020 oil mist detector.....	137
Fig.: 82 :	Replacing the seal on the connecting box (steps 1- 13), VN2020	143
Fig.: 83 :	Measuring head, VN2020 oil mist detector	145
Fig.: 84 :	Replacing the VN2020 measuring head (steps 1-9)	150
Fig.: 85 :	Replacing the fuse on the VN2020 measuring head (steps 1-3)	151
Fig.: 86 :	VN2020 inspection cover screw plug	153
Fig.: 87 :	Replacing the screw plug on the VN2020 measuring head (steps 1-3).....	154
Fig.: 88 :	Terminal box (spare part), VN2020.....	155
Fig.: 89 :	Replacing the VN2020 terminal box (installation steps 1-8)	161
Fig.: 90 :	Filter control valve, VN2020 oil mist detector.....	162
Fig.: 91 :	Replacing the filter control valve (steps 1-8)	166
Fig.: 92 :	Connecting hose, VN2020 oil mist detector.....	167
Fig.: 93 :	Replacing the connecting hose (steps 1-4).....	169
Fig.: 94 :	VN2020 measuring head: “System or device error” status indicator	172
Fig.: 95 :	Overview of the positions of spare parts (kept in stock) for the VISATRON® VN2020...	178
Fig.: 96 :	Cleaning kit for VISATRON® VN2020/VN2020 EX	180
Fig.: 97 :	Overview, positions of spare parts (kept in stock) for the VISATRON® VN2020 EX	182
Fig.: 98 :	Maintenance kit for the VISATRON® VN2020/VN2020 EX.....	184
Fig.: 99 :	Service kit for the VISATRON® VN2020/VN2020 EX	185

15 List of tables

Table 1 : Version history and change notes	3
Table 2 : Variables and units of measurement that are used.....	14
Table 3 : Information, warning and mandatory signs.....	18
Table 4 : Mechanical interfaces	29
Table 5 : Electrical interfaces.....	30
Table 6 : Pneumatic interfaces	30
Table 7 : Ambient conditions and physical characteristics	30
Table 8 : Type approval for closed areas	31
Table 9 : Setting the device sensitivity	42
Table 10 : Storage conditions before starting up.....	45
Table 11 : Checklist for startup	94
Table 12 : Assignment table (sensitivity/opacity).....	101
Table 13 : Parameter list.....	112
Table 14 : Maintenance cycles	123
Table 15 : Error diagnosis.....	174
Table 16 : Troubleshooting	175
Table 17 : Recommended spare parts (kept in stock) for emergencies, VISATRON® VN2020	179
Table 18 : Cleaning kit for VISATRON® VN2020/VN2020 EX.....	180
Table 19 : Service box for the VISATRON® VN2020/VN2020 EX	181
Table 20 : Recom. spare parts (kept in stock) for emergencies, VISATRON® VN2020 EX.....	183
Table 21 : Maintenance kit for the VISATRON® VN2020/VN2020 EX	184
Table 22 : Service kit for the VISATRON® VN2020/VN2020 EX.....	186
Table 23 : Device update (measuring head) for the VISATRON® VN2020 / VN2020 EX.....	187
Table 24 : List of accessories for VISATRON® VN2020/VN2020 EX.....	189

16 Glossary

Term	Description
VN2020/VN2020 EX	Non Ex/Ex oil mist detector type designation, designed to protect large engines (gas, diesel and dual fuel)
Measuring head	Provides the functionality of the oil mist detection system and is used to adjust parameters of measured variables
Engine wall connection	Used to draw in the oil mist atmosphere from the crankcase in a defined manner
Header pipe	Directs the oil mist atmosphere from the engine wall connection directly to the oil mist detector
Mounting position	Position at which the oil mist detector (including the protective cover) is attached to the engine
Bracket	Used to hold the oil mist detector and to connect the oil mist detector to the engine housing
Siphon block	Alternative in the installation kit to the engine wall connection (EWC).
Pipe siphon	Drains precipitated oil from the oil mist atmosphere to prevent blockages in the header pipe.
Oil mist concentration	Volume-specific components of the atmosphere sucked in from the crankcase
Opacity	Degree in [%] to which the atmosphere sucked in from the crankcase is opaque
Intake position	Position at which the gas to be measured is taken in from the crankcase or the central suction system.
Crankcase atmosphere	Atmosphere (potentially explosive in part) which is permanently present in the crankcase of a large engine
Lower explosive limit (LEL)	Lower explosive limit of a gas or gas mixture
Upper explosive limit (UEL)	Upper explosive limit of a gas or gas mixture
Oil mist detection	Detection and analysis of oil mist concentrations previously taken from the crankcase of a large engine
IACS	International Association of Classification Societies Umbrella organisation for various classification societies
M10	Class-compliant assembly and installation according to the IACS requirements
M67	Sensitivity of the oil mist detector and determination of the oil mist concentration according to IACS requirements
Communication interface	Interface for data transfer, depending on suitable data protocols (e.g. CAN, RS485 etc.)
Remote Indicator II	Remote monitoring system for displaying oil mist concentration and the status of VISATRON® oil mist detection systems.
Non-potentially explosive atmosphere	Areas in which no explosive atmosphere can arise
Potentially explosive atmosphere	Areas in which a permanent potentially explosive atmosphere can occur

17 EC Declaration of Conformity

EC Declaration of Conformity

In accordance with the EU Machinery Regulation (EU) 2023/1230
Annex V, Part A

We hereby declare on our sole responsibility that the design of the machine described below and the version we have placed on the market fulfils the essential health and safety requirements of Machinery Directive (EU) 2023/1230.

Manufacturer: **SCHALLER AUTOMATION**
Industrielle Automationstechnik GmbH & Co. KG
Industriering 14
D-66440 Blieskastel, Germany

Type of device: Oil mist detector (OMD)
Type designation: VISATRON® VN2020
Intended use: Detection and display of oil mist in large engines
Serial number/year of manufacture: The serial number and year of manufacture are on the product. A complete list is documented in the production documents.

We declare that the product complies with further Directives applicable to the product, as follows:

- EMC Directive 2014/30/EU

Applied harmonised standards:

- EN ISO 12100:2010-11
- EN ISO 4414:2010-11
- EN 60529:2014-09
- EN 61000-6-1:2019-11
- EN 61000-6-2:2019-11
- EN 61000-6-3:2011-09
- EN 61000-6-4: 2011-09
- EN 60079-28:2016-04

Applied national standards and technical specifications:

- IACS UR M10: Rev.4 2013
- IACS UR M67: Rev.2 2015

This EU declaration of conformity shall no longer be valid if:

- the machine is rebuilt, modified or used for purposes other than those for which it is intended without our written consent;
- the instructions in the operating manual are not followed.

D-66440 Blieskastel, Germany, 28 April 2026

Stephan Schaller
(Managing Director)

EU Declaration of Conformity

In accordance with the EU Machinery Regulation (EU) 2023/1230
Annex V, Part A

We hereby declare on our sole responsibility that the design of the machine described below and the version we have placed on the market fulfils the essential health and safety requirements of Machinery Directive (EU) 2023/1230.

Manufacturer: **SCHALLER AUTOMATION**
Industrielle Automationstechnik GmbH & Co. KG
Industriering 14
D-66440 Blieskastel, Germany

Type of device: Oil mist detector (OMD)
Type designation: VISATRON® VN2020 EX
Intended use: Detection and display of oil mist in large engines
Serial number/year of manufacture: The serial number and year of manufacture are on the product. A complete list is documented in the production documents.

Marking: **CE 0637 Ex II (2G) [Ex op is IIB T4 Gb]**

We declare that the product complies with further Directives applicable to the product, as follows:

- EMC Directive 2014/30/EU
- ATEX Directive 2014/34/EU

Applied harmonised standards:

- EN ISO 12100:2010-11
- EN ISO 4414:2010-11
- EN 60529:2014-09
- EN 61000-6-1:2019-11
- EN 61000-6-2:2019-11
- EN 61000-6-3:2011-09
- EN 61000-6-4: 2011-09
- EN IEC 60079-0:2019-09
- EN 60079-28:2016-04

Applied national standards and technical specifications:

- IACS UR M10: Rev.4 2013
- IACS UR M67: Rev.2 2015
- IEC 60079-0 (2017) and IEC 60079-28 (2015)

This EU declaration of conformity shall no longer be valid if:

- the machine is rebuilt, modified or used for purposes other than those for which it is intended without our written consent;
- the instructions in the operating manual are not followed.

D-66440 Blieskastel, Germany, 28 April 2026



Stephan Schaller
(Managing Director)

18 Attachments

18.1 Description of error on the VN2020/VN2020 EX oil mist detector

Why is the oil mist detector faulty?

If your oil mist detector is defective or malfunctions, please contact Schaller Automation or one of our authorised service partners immediately. Please fill in the following form in full and send it to us immediately together with the defective part.

See Section 12 (⇒ *Section 12 Contact*) in this manual for suitable partners or go to <https://schaller-automation.com/en/partners/> for the contact details of Schaller Automation and other partners near you.

We are also available to answer any questions you may have about using the product. Please also use the form below for this purpose and ask your question(s) in detail. Please send the form to us by email, fax or post and we will reply as soon as possible.

Name	
Ship/factory	
IMO number (only for ships)	
Shipowner/company	
Phone	
Fax	
Email	

Please enter your data for product identification:

Oil mist detector model: (Please select)

VN2020 VN2020 EX

Serial number: (See label on the front)

<input type="text"/>	<input type="text"/>	<input type="text"/>	<input type="text"/>	<input type="text"/>	<input type="text"/>	<input type="text"/>	<input type="text"/>	<input type="text"/>	<input type="text"/>
----------------------	----------------------	----------------------	----------------------	----------------------	----------------------	----------------------	----------------------	----------------------	----------------------

Oil mist detector installed on: (Please select)

Main machine Auxiliary machine/power unit

Engine manufacturer: _____

Engine type: _____



1. Condition of the oil mist detector:

Oil mist detector mechanically damaged? : Not functioning when operated? :

2. Checked whether sampling on the oil mist detector is working properly? Yes No

3. Is the condition of the intake line OK? Yes No

4. Is the condition of the intake line seal OK? Yes No

5. Are any of the LEDs on the measuring head coming on? Yes No

Check whether measuring head is ready for operation

Check the supply lines

Check the power supply on the measuring head (test with multimeter)

Minimum voltage: 18 V

Maximum voltage: 31.2 V Measured voltage: V

6. Problems with performance:

Emergency shutdown following oil mist alarm for no apparent reason.

- **Device issues oil mist alarm from time to time** , or **permanently**

During: Engine start Warm-up
 Increase in load Decrease in load
 Engine stop In various states

- **Have you checked the crankcase?** Yes No

If yes, did you find damage? Yes No

Did you find water leakage? Yes No

Did you find condensation? Yes No

- **Is the supply line OK and cable routing checked?**

Yes No

If yes: Is cable routing OK? Yes No

Are plug connections OK? Yes No

- **Check the light path and clean if necessary**

Is the light path wetted with oil? Yes No

Is there condensate in the light path? Yes No

- **Check the negative pressure at the measuring head and check the pressure section**

Setting value for negative pressure on the measuring head: **60 mmWC ± 5 mmWC**

Measured negative pressure at the measuring head: mmWC

Is the working pressure between the filter control valve and the venturi injector completely or partially interrupted?

Yes No

See also Section 10.2 → *Section 10.2 Error diagnosis and troubleshooting* → Codes 14 and 33

If yes, please check as follows:

Is there no compressed air available? Yes No

If there is, is there enough/too much compressed air available?

Is the filter of the filter control valve very dirty? Yes No

Does the green Ready LED on the measuring head come on? Yes No

Does the red system failure LED on the measuring head come on? Yes No

Additional information from customer:

20 Index

Adjusting the parameters	110	Notation and symbols	9
Alarm	118, 136	Operating manual	9
Alarm thresholds	109	Operating modes	37
Assembly	46	Operating the product	114
Checklist	94	Operation	114
Claims	12	Parameter list	112
Cleaning	124	Power supply	95
Conformity	11	Product overview	32
Controls and indicators	43	Qualifications of personnel	10
Customer service	177	Qualified personnel	10
Device variants	22	Remote Indicator II	76
Directives	11	Safety instructions	15, 18
Earth connection	92	Sensitivity	41
Error	173	Sensor sensitivity	101
Explosion protection classification	42	Setup	32, 34
Fault indicators	43	Signs	17
Final shutdown	176	Spare parts	178
Function	36	Starting up	46, 93
Information about the operating manual ..	9	Starting up again	170
Inspection	143	Storage	44
Installation	46	Storage period	44
Intended use	42	Switching on and off	115
Interfaces	29, 30	Symbols and signs	17
M67	49	Taking out of service	170, 171
Maintenance	120	Transport	44
Maintenance and inspection work	143	Variables and units of measurement ...	13
Maintenance cycles	122	Warnings	15
Name plate	23, 25	Warranty and liability	12
Normal operation	115	Working condition	121

SCHALLER 
AUTOMATION

OUR PASSION. YOUR SAFETY.

- since 1956 -

