

# INSTALLATION INSTRUCTIONS

**VISATRON® Upgrade KIT**  
(Order number: 2001560)

**VN115/87plus »» VN2020**



**Version date:** 28/04/2026  
**Version:** Version 1.0  
**Document No.:** Part number 2001570

The original installation instructions are written in German.  
Any translations are based on the original installation instructions.

## LEGAL NOTICE

The installation instructions apply to the following product:

- VISATRON<sup>®</sup> VN2020

Firmware version at time of publication:  
V2.03 dated 12/04/2024

---

### Copyright

This manual is protected by copyright. All rights are reserved.

We reserve the right to make technical changes to the hardware and software of our VISATRON<sup>®</sup> products without prior notice. We do not assume any liability for a currently delivered device having all the features described in this operating manual.

The reproduction, translation, microfilming and the storage and processing of this manual, including in part, is only allowed with the consent of Schaller Automation Industrielle Automationstechnik GmbH & Co. KG.

Any infringement shall attract damages and may have consequences under criminal law. Specifications of nominal conditions, technical changes, improvements and errors are excepted.

This operating manual may only be passed on to third parties in conjunction with the transfer of the relevant VISATRON<sup>®</sup> device.

Copyright © 2026

**Schaller Automation** Industrielle Automationstechnik GmbH & Co. KG  
Industriering 14  
66440 Blieskastel Saarland  
Germany

Phone: +49 (0) 6842- 508- 0  
Fax: +49 (0) 6842- 508- 260

Email: [info@schaller.de](mailto:info@schaller.de)  
Website: [www.schaller-automation.com](http://www.schaller-automation.com)

## VERSION HISTORY AND CHANGE NOTES

Version	Change	Date	Author
1.0	First version	28/04/2026	J. Wahl

Table 1: Version history and change notes

## Table of contents

<b>1</b>	<b>Information about the installation instructions</b> .....	<b>5</b>
1.1	Symbols in these installation instructions.....	5
1.2	Validity of the installation instructions.....	5
1.3	Applicable documents and regulations .....	5
1.4	Digital installation instructions (online installation instructions).....	6
1.5	Qualifications of personnel .....	6
1.6	Important Information for the Operator.....	6
1.7	Legal information about the product.....	6
<b>2</b>	<b>Safety instructions</b> .....	<b>7</b>
2.1	Information, warning and mandatory signs that are used .....	7
2.2	General safety instructions .....	8
<b>3</b>	<b>Instructions for the Upgrade KIT</b> .....	<b>10</b>
3.1	Items included in the Upgrade KIT .....	11
<b>4</b>	<b>Unpacking and storage</b> .....	<b>16</b>
4.1	Unpacking.....	16
4.2	Storage conditions before putting into service .....	16
<b>5</b>	<b>Taking out of service, disassembly (used device)</b> .....	<b>17</b>
5.1	Taking the compressed air supply out of service .....	17
5.2	Taking the electrical power supply out of service.....	17
<b>6</b>	<b>Assembly and installation - VN2020 Upgrade Kit</b> .....	<b>18</b>
6.1	Assembling the VISATRON® VN2020 oil mist detector .....	18
6.2	Assembling the intake and connection lines .....	19
6.3	Installing the return line (exhaust air hose) .....	20
6.3.1	Installing the return line for inspection cover with wall thickness > 5 mm .....	22
6.3.2	Installing the return line for inspection cover with wall thickness ≤ 5 mm .....	25
6.4	Electrical installation of the terminal box .....	28
6.5	Electrical connection of the Remote Indicator II (optional).....	32
6.6	Closing the terminal box after completing the electrical installation.....	32
6.7	Connecting housing earth to the protective cover of the VN2020.....	32
<b>7</b>	<b>Putting into service, operating and using</b> .....	<b>33</b>
<b>8</b>	<b>Maintenance, repair and diagnostics</b> .....	<b>34</b>
<b>9</b>	<b>Spare parts and accessories, VN2020 (extract)</b> .....	<b>35</b>
<b>10</b>	<b>Contact</b> .....	<b>36</b>
<b>11</b>	<b>Notes</b> .....	<b>37</b>
<b>12</b>	<b>Customer information</b> .....	<b>38</b>

# 1 Information about the installation instructions

These instructions are original installation instructions based on Machinery Regulation 2023/1230 (EU) and are structured with text and images. It contains important information about installation of the product, in particular the safety instructions and warnings.

**Please read the instructions carefully, then keep them in a safe place!**

## 1.1 Symbols in these installation instructions

Various types of notation and symbols are used in the text of this manual. They are used as follows:

Numbered steps:

- ▶ Required action
  - ☑ Result of the sequence of actions
- Symbol for a list
  1. Points of the list

⇒ *Reference to a section or figure*

Display text



Additional information and instructions



Environmental and energy-saving tips



Different warning symbols are used for warnings. Please see the descriptions and instructions in Section ⇒ *Section 2 Safety instructions*

## 1.2 Validity of the installation instructions

These installation instructions apply to the following product:

- **VISATRON® VN2020**

hereafter referred to as the "device".

## 1.3 Applicable documents and regulations

Further documents apply and must be observed in conjunction with these installation instructions:

- ▶ Operating manual for **VISATRON® VN2020**, currently valid version and various languages in translation (Document No.: 183000\_DE, available on the supplied DVD)
- ▶ Operating manual for **VISATRON® VN115/87plus**, currently valid version and various languages in translation (Document No.: 180093\_DE, available to download from the online portal)
  - ⇒ *Section 1.4 Digital installation instructions (online installation instructions)*
- ▶ For additional components, the manuals supplied with them must be observed.

## 1.4 Digital installation instructions (online installation instructions)

The current version of these installation instructions is also available online and can be accessed at any time. Available at:

[Installation instructions | Schaller Automation \(schaller-automation.com\)](https://www.schaller-automation.com)

To access the manual, select the manual for your product on our online portal and then start downloading by clicking the  icon. The document then opens automatically in your browser.

## 1.5 Qualifications of personnel

Installation, putting into service, operation and maintenance of the device may only be carried out by appropriately qualified personnel.

The operator must therefore ensure that the personnel for the work/activities defined in this operating manual have the appropriate qualifications and fully understand the contents of these installation instructions.

The operator must define and provide rules for the area of responsibility, the authority and the supervision of personnel for such work in advance.

## 1.6 Important Information for the Operator

Modifications to the engine and its associated systems carried out by the operator—particularly those that may affect operational safety, compliance with statutory regulations, or the classification of the vessel—must be reported to the competent classification society prior to the commencement of the work. This applies in particular to:

- New installations,
- Retrofit measures, or
- Upgrades.

## 1.7 Legal information about the product

For all legal questions and activities arising in connection with the above product, please contact SCHALLER Automation in advance:

**SCHALLER Automation (Headquarters)**  
Industrielle Automationstechnik GmbH & Co. KG

Industriering 14  
66440 Blieskastel/Saarland  
Germany

Phone: +49 (0) 6842 508-0  
Fax: +49 (0) 6842 508-260

Email: [info@schaller.de](mailto:info@schaller.de)  
Website: [www.schaller-automation.com](http://www.schaller-automation.com)

## 2 Safety instructions

### 2.1 Information, warning and mandatory signs that are used

The following symbols and signs according to DIN EN ISO 7010 and DIN 4844-2 are used in these installation instructions:











Symbol	Explanation
	General warning sign
	Warning; electricity
	Warning; hot surface
	Warning; the risk of being drawn in unintentionally (body parts)
	Warning; risk of being crushed (body parts)
	Warning; risk of slipping, tripping and falling, caused by the working environment
	Disconnect before carrying out maintenance or repair Connect an earth terminal to the ground
	Use personal protective equipment (PPE)
	Refer to operating manual/instructions
	Note: Important information!
	Note: Action required!

Table 2: Information, warning and mandatory signs

## 2.2 General safety instructions

The basic safety instructions are instructions that always apply in order to operate the machine safely and keep the device in a safe condition.

If the following safety instructions are not observed, the following may occur:

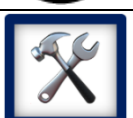
- there may be personal injury, environmental damage or damage to property;
- important functions of the device may fail;
- specified methods of maintenance and servicing may fail;
- any claims may not apply.



### CAUTION



#### Safe and proper use of the device

- ▶ Read the operating manual and other documents that accompany the product carefully and keep them in a suitable place for future reference.
- ▶ For repair and service work, you must follow the instructions in the operating manual.

### NOTE



#### Personal protective equipment

Operating the device or working on the device without protective equipment may result in serious injury. For the workplace PPE, the following protective equipment must be used:

- ▶ DIN EN 388:2016 Protective gloves against mechanical risks, 2341X, and DIN EN 407:2020-06, Protective gloves against thermal risks, X1XXXX.
- ▶ Safety glasses in accordance with DIN EN 166 or DIN EN 170.
- ▶ Safety helmet in accordance with DIN EN 397 or DIN EN 50365.
- ▶ ESD safety shoes according to ESD standard DIN EN 61340-5-1.



### DANGER



#### Malfunction

Operating the device with a malfunction creates a risk of death and may cause environmental damage and/or damage to the device.

- ▶ The device must be taken out of operation immediately in the event of a malfunction.



### DANGER



#### Noise pollution

At the mounting position of the device, there are high noise emissions from running of the engine, which can damage hearing and cause environmental noise pollution.

- ▶ Wear suitable ear protection when the engine is running.
- ▶ Observe the statutory regulations for protection against noise.



## DANGER

### Mechanical hazards

Serious injuries from incorrect assembly or installation.

- ▶ You may only install and remove the device when the engine is switched off, and the complete set of all components must be attached.
- ▶ The device must be installed and aligned in accordance with Section 6.1 of these instructions. ⇒ *Section 6.1 Assembling the VISATRON® VN2020 oil mist detector*
- ▶ The device must not be painted, varnished or otherwise altered in any other way.
- ▶ The mechanical connection for the return of the sampled crankcase atmosphere is installed **on the inspection cover of the engine only**.  
⇒ *Section 6.3 Installing the return line*

➔ **For safety reasons, the engine housing wall must not be used to create through-holes.**



## DANGER

### Pneumatic hazards

Assembly, installation and disassembly of the device must only be carried out when the device is not under pressure.

- ▶ Before starting work, deactivate the compressed air supply.

Risk of asphyxiation or explosion of the crankcase atmosphere in the engine room.

- ▶ The exhaust air from the intake system (venturi injector) must be returned to the crankcase and must not get into the engine room.

The following therefore applies:

- ▶ The exhaust air line of the oil mist detector must always be connected to the crankcase (inspection cover) (closed circuit). The correct negative pressure in the measuring head should be 60 mmWC.
- ▶ The oil mist detector with return of the crankcase atmosphere into the crankcase is suitable for a crankcase pressure in the range of  $\pm 500$  mmWC under normal operating conditions.



## NOTE

### Maintenance and repair work

It is only safe to operate the device when it is in perfect working condition. The operator is responsible for proper and safe condition of the device, which means:

- ▶ Have the specified inspections and maintenance work carried out regularly.
- ▶ The specified checks must be carried out before operation.



## WARNING

### Risk of injury from design changes

Unauthorised modification or removal of functional parts puts the function of important safety components at risk and can lead to serious damage to property or the environment and to serious injuries or even death.

- ▶ Statutory regulations must be observed and complied with.
- ▶ Only use approved and suitable components and spare parts.

### 3 Instructions for the Upgrade KIT

The VISATRON® VN2020 Upgrade Kit is designed for the following models of our reliable Schaller Automation oil mist detectors:

- VISATRON® VN115/87
- VISATRON® VN115/87plus
- VISATRON® VN116/87
- VISATRON® VN116/87plus

The VISATRON® VN2020 is generally compatible with predecessor models, with the following exceptions:

- The VISATRON® VN2020 Upgrade Kit includes a new innovative pressure control valve. This has additional filtering of the compressed air and a water/oil separator to improve system reliability. The existing pressure control valve from the VN87/VN87plus series is **not** compatible and can **no longer** be used.
- The VISATRON® VN2020 requires a closed control circuit for intake and return of the crankcase atmosphere. To use the device safely and correctly, this means that the sampled crankcase atmosphere must be directed back into the crankcase after measurement.

⇒ Section 6.3 *Installing the return line*

- Changes to the electrical connections:

Compared to the VISATRON® VN87 and 87plus, the VISATRON® VN2020 has a modified terminal layout, which is now integrated in a separate terminal box. For more information, see Section 6.4 of these instructions.

⇒ Section 6.4 *Electrical installation of the terminal box*

The optional 4-20 mA interface is also no longer available on the VISATRON® VN2020. However, the remote monitoring function using the Remote Indicator II is still provided via the RS485 interface. For more information, see Section 6.4.3 of the current VISATRON® VN2020 operating manual.

⇒ Section 1.3 *Applicable documents and regulations*

**NOTE:** The VISATRON® VN2020 is also available as an ATEX or IECEx version for potentially explosive atmospheres. If required or if interested, please contact Schaller Automation directly or an authorised service partner (see Section 10 of these instructions). ⇒ Section 10 *Contact*

Alternatively, visit our homepage to find your nearest service partner. <https://schaller-automation.com/partner/>

### 3.1 Items included in the Upgrade KIT



**NOTE**

The VISATRON® VN2020 Upgrade KIT includes significantly more single parts than are actually required. This means users have the benefit of being able to operate various different configurations and installation variants using a single product set.

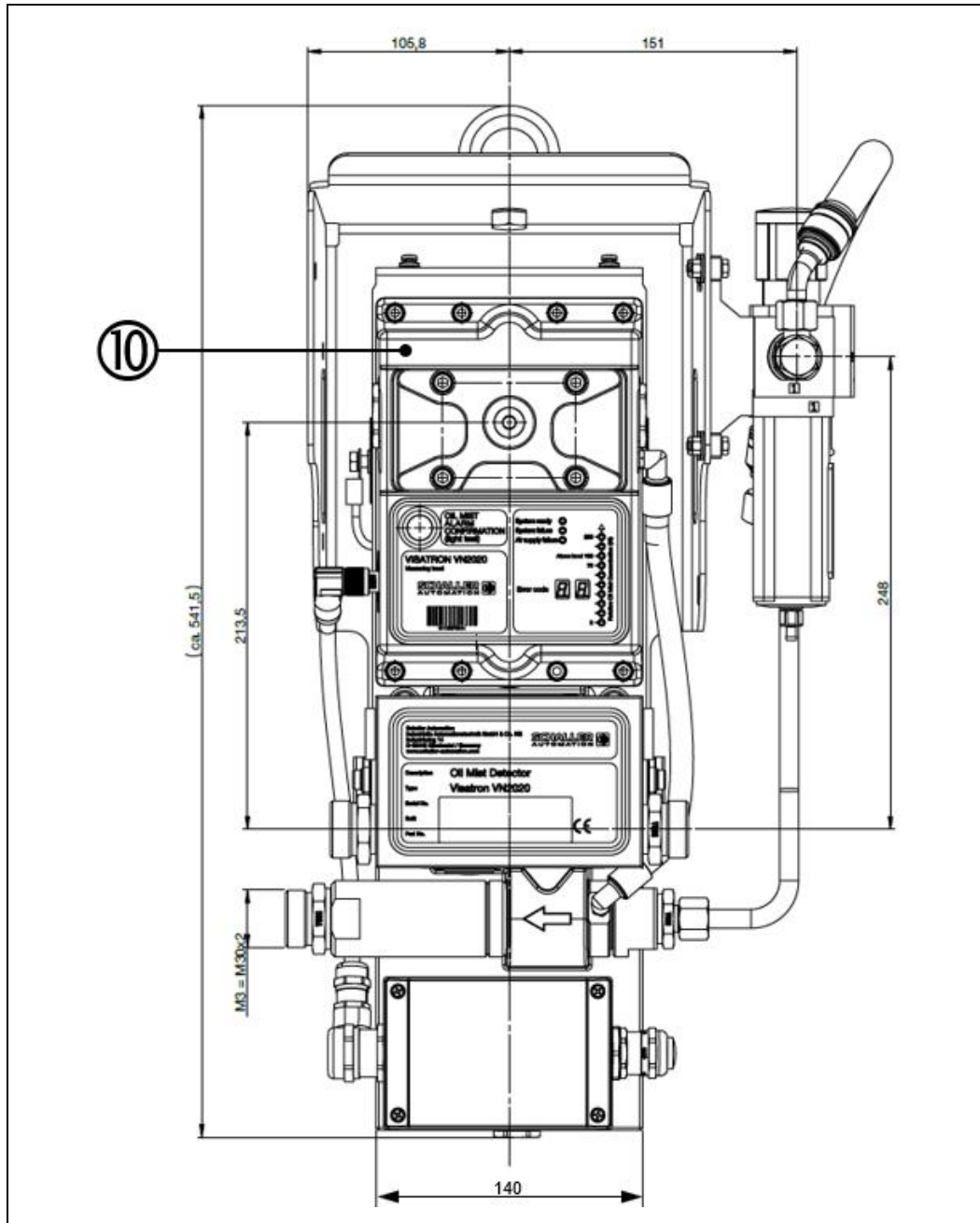

Fig.: 1 : "Upgrade Device" component overview, VISATRON® VN2020

Item	Part Number	Description	Qty	Bag No.
10	2001559	VISATRON® VN2020 Upgrade Device	1	-

Table 3: "Upgrade Device" component, VISATRON® VN2020

Cable gland

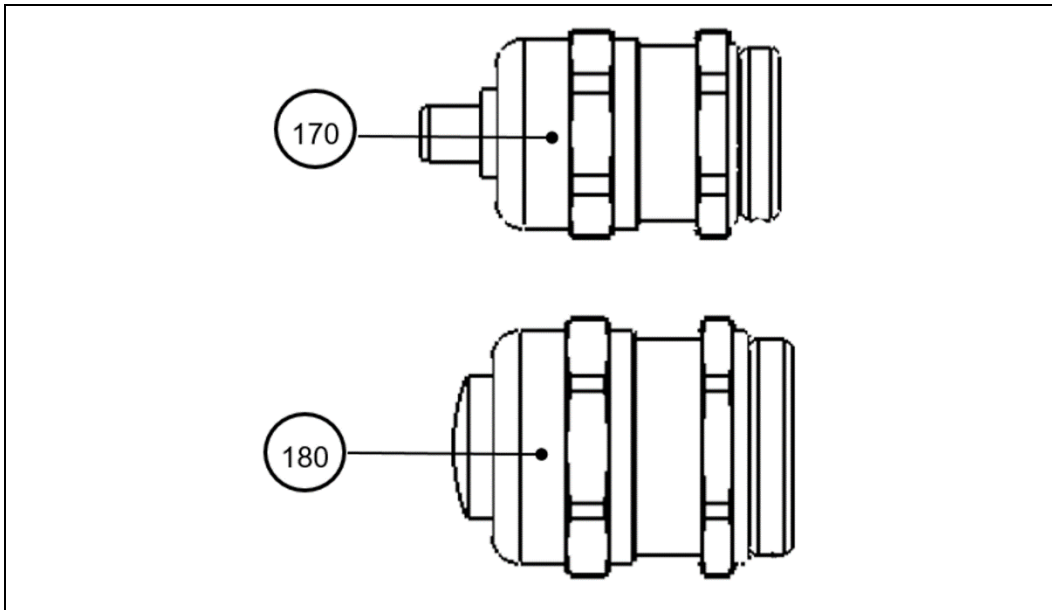

Fig.: 2 : "Cable gland" component overview, VISATRON® VN2020 Upgrade Kit

Item	Part Number	Description	Qty	Bag No.	Outer bag (A)
170	273441	Cable gland M20, pre-assembled: Cable diameter: Ø8-16 mm	1	A1	Cable gland
180	273442	Cable gland M25, pre-assembled: Cable diameter: Ø8-16 mm	1	A2	

Table 4: "Cable gland" components, VISATRON® VN2020 Upgrade Kit

Intake

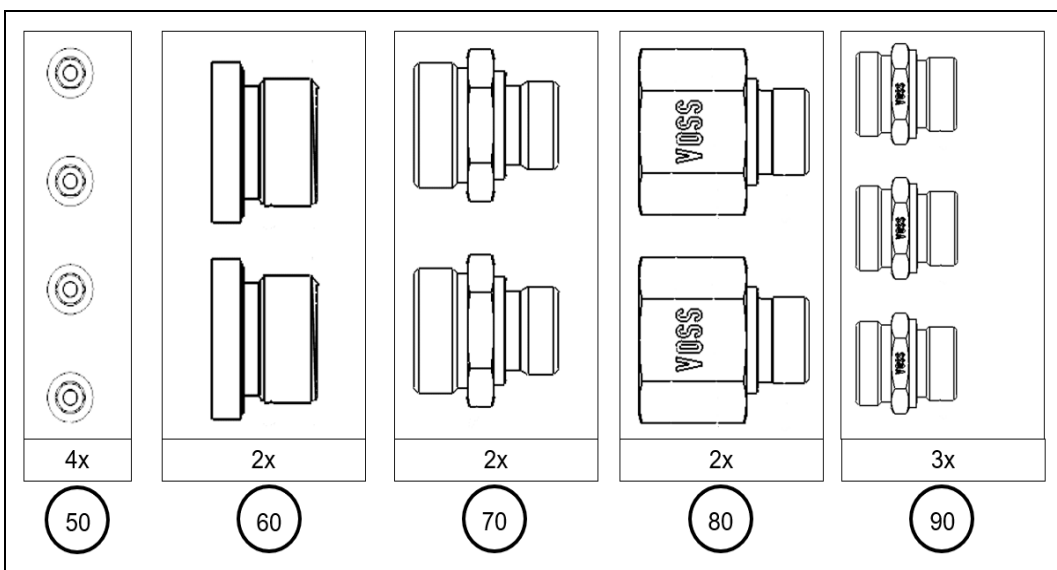

Fig.: 3 : "Intake" component overview, VISATRON® VN2020 Upgrade Kit

Item	Part Number	Description	Qty	Bag No.	Outer bag (B)
50	481035	Disc nut, captive, M8 in F8.8	4	B1	Intake
60	366712	Screw plug ISO 8434-1-G1/2	2	B2	
70	366711	Pipe connector ISO 8434-1-SDS-L22xG1/2-B-St	2	B3	
80	2001049	Pipe connector ISO 8434-1-SDS-G1/2B-IG3/4	2	B4	
90	366759	Pipe connector ISO 8434-1-SDS-L22xG3/4-E-St	3	B5	

Table 5: "Intake" components, VISATRON® VN2020 Upgrade Kit

**Return**

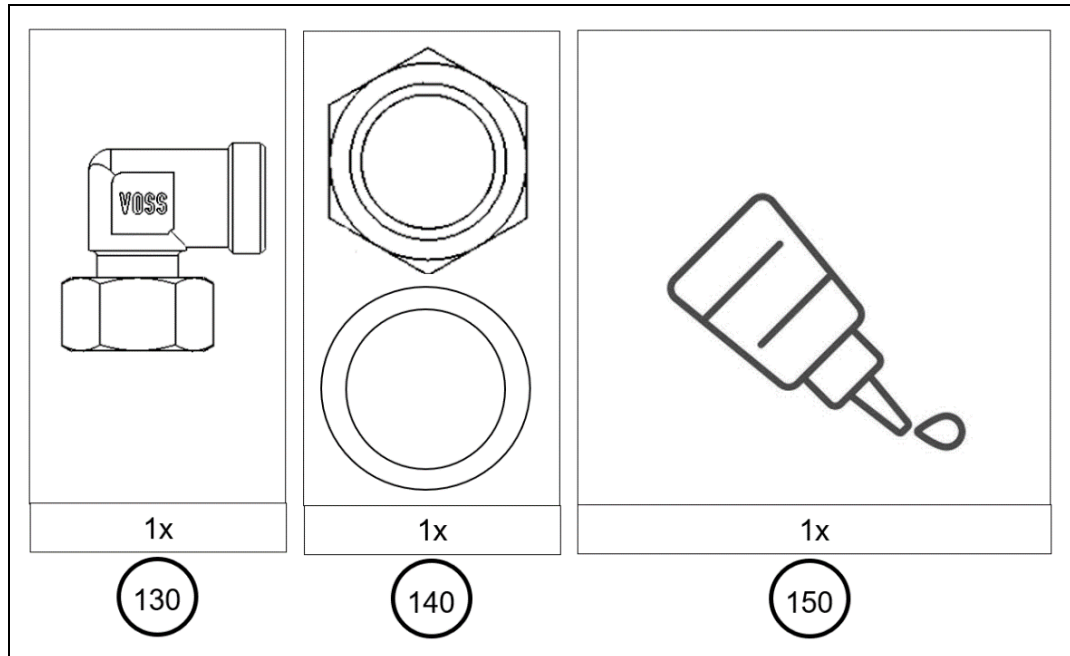

Fig.: 4 : "Return" component overview, VISATRON® VN2020 Upgrade Kit

Item	Part Number	Description	Qty	Bag No.	Outer bags (C), (D)
130	366741	Pipe connector ISO 8434-1-SWE-L22-St	1	C1	Return
140	481378 481047	Lock washer S - 25.4 - spring steel zinc-plated Hex nut DIN 431 - G3/4 - A2-70	1	C2	
150	450180	Loctite Blue 5ml	1	D1	

Table 6: "Return" components, VISATRON® VN2020 Upgrade Kit



**IMPORTANT INFORMATION**

**Instructions and installation options**

- ▶ The mechanical connection for the return of the sampled crankcase atmosphere is installed **on the inspection cover of the engine only**. → Section 6.3 *Installing the return line*
  - ➔ **For safety reasons, the engine housing wall must not be used to create through-holes.**
- ▶ For inspection cover wall thicknesses **up to ≤ 5 mm**, use Item 140 and Item 90 (according to Table 5).
- ▶ For inspection cover wall thicknesses **> 5 mm**, do not use Item 140, or first drill a through-hole and then insert a G3/4 thread into the inspection cover. Use Item 90 (according to Table 5).

**Return line (exhaust air hose)**

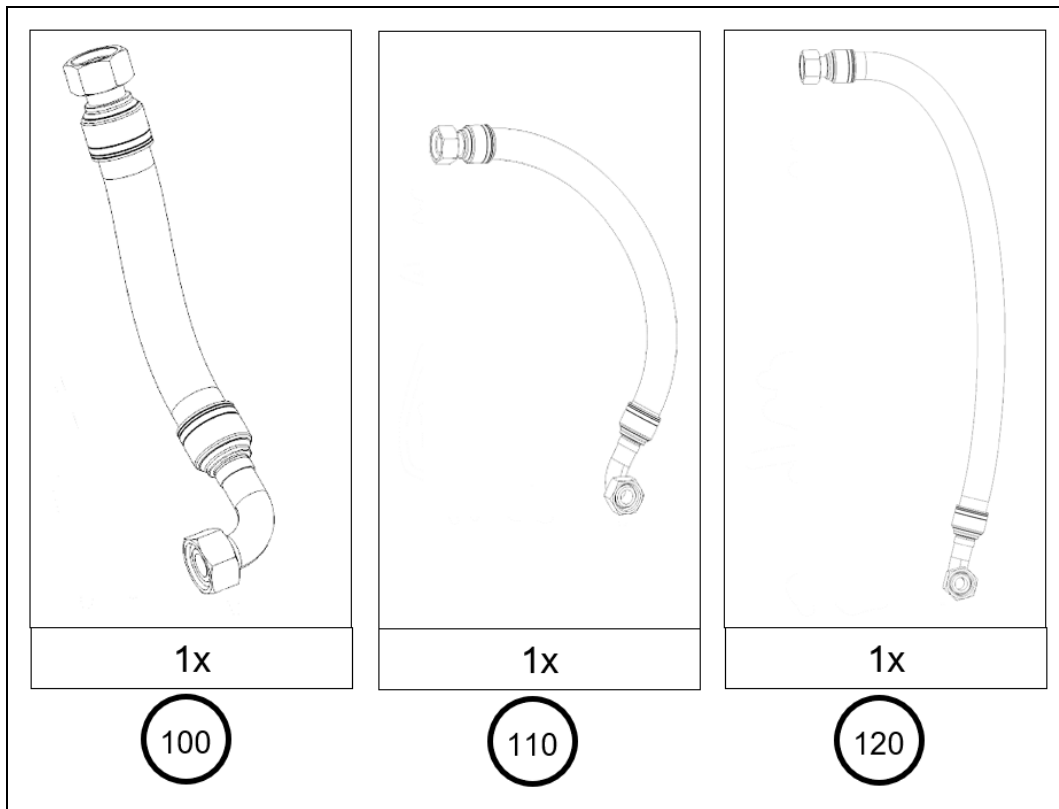

Fig.: 5: "Return line" component overview, VISATRON® VN2020 Upgrade Kit

Item	Part Number	Description	Qty	Bag No.	Outer bag
100	271432	Intake hose DN19 x 330	1	-	-
110	271258	Intake hose DN19 x 550	1	-	-
120	272491	Intake hose DN19 x 770	1	-	-

Table 7: "Return line" components, VISATRON® VN2020 Upgrade Kit

**Set of resistors**

Item	Part Number	Description	Qty	Bag No.	Outer bag
<b>125</b>	273112	Set of resistors 24K9 with bent leads 10K0 with bent leads 3K32 with bent leads 8K25 with bent leads	1	-	-

Table 8: "Set of resistors" component, VISATRON® VN2020 Upgrade Kit

## 4 Unpacking and storage

### 4.1 Unpacking

When you receive the VISATRON® VN2020 Upgrade Kit, check the whole delivery to ensure that it contains all the components. Schaller Automation provides a detailed parts list for you to use for this purpose.

⇒ Section 3.1 Items included in the Upgrade KIT

Delivery is ex works in accordance with the applicable terms and conditions of contract and in a ready-to-use condition.



<b>CAUTION</b>	
<b>Damaged components can cause damage to machinery and persons.</b>	
<ul style="list-style-type: none"> <li>▶ On receipt of the delivery, make sure immediately that it is correct, complete and undamaged. Report any visible transport damage to the responsible transport company immediately.</li> </ul>	



<b>NOTE</b>	
Dispose of the packaging materials in accordance with your local disposal regulations in the containers provided for this purpose.	

### 4.2 Storage conditions before putting into service

The maximum storage period for the VISATRON® VN2020 Upgrade Kit is 12 months **after** receipt of goods in the original packaging. Store the device in a place that meets the following conditions:

- The room is closed (dry and free from dust)
- There is no exposure to wind or rain
- There is no exposure to flammable, volatile or corrosive gases or dust, and no exposure to vibrations -> the place must be stable and free of hazards.

Storage temperature range	-25°C to max. 50°C
Air humidity	< 85% RH avoiding condensation

Table 9: Storage conditions before putting into service



<b>CAUTION</b>	
<b>Incorrect storage can damage the device.</b>	
<ul style="list-style-type: none"> <li>▶ Keep the storage period for the device to a minimum.</li> <li>▶ Keep the device in its original packaging.</li> <li>▶ If stored for a longer period, check the condition of the device regularly and carry out corrosion protection measures, if necessary.</li> <li>▶ Note the warranty period under the General Terms &amp; Conditions.</li> </ul>	

## 5 Taking out of service, disassembly (used device)

The device is taken out of service mechanically and electrically and the used device, including the necessary supply lines, is disassembled in the reverse order to putting into service as per Section 2.0 of the **VN115/87plus operating manual**.

⇒ Section 1.3 Applicable documents and regulations

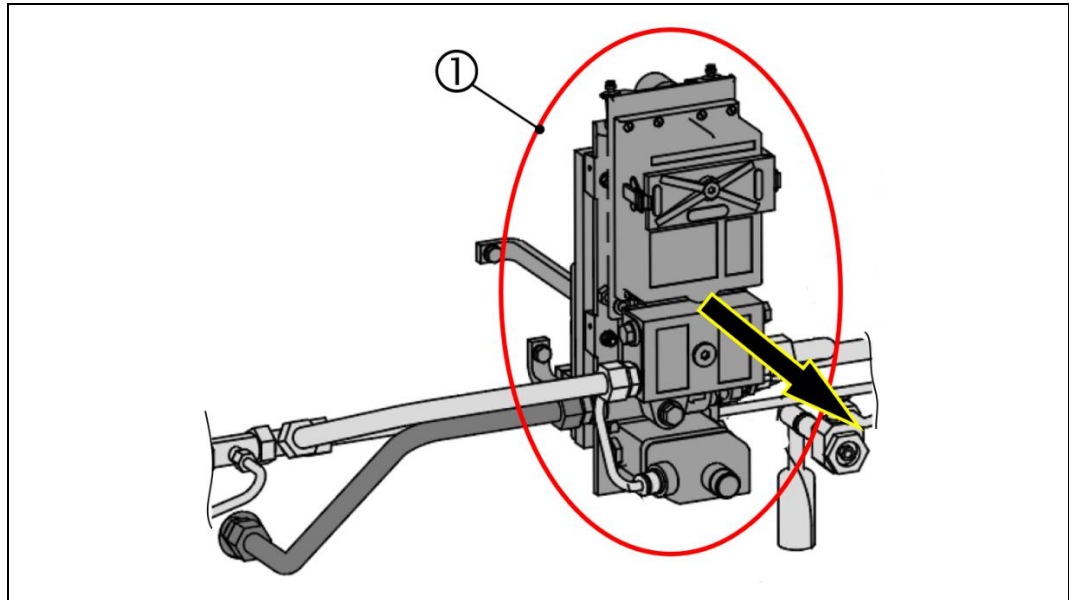

Fig.: 6 : Disassembling the "used device", VISATRON® VN87/VN87plus

1: VN87/VN87plus used device (example diagram)

### 5.1 Taking the compressed air supply out of service

When taking the device out of service and disassembling it, the compressed air supply must first be switched off by the customer.



#### WARNING

##### Mild to severe bruising when handling compressed air

Risk of injury from whipping of the compressed air hose line.

- ▶ Before starting work on the VISATRON® VN87/VN87plus, release the pressure from the compressed air hose line.

### 5.2 Taking the electrical power supply out of service

When taking the device out of service and disassembling it, the electrical power supply must first be switched off by the customer.



#### DANGER

##### Electrical hazards

- ▶ Before starting work, disconnect the VISATRON® VN87/VN87plus from the power supply or make sure that the housing is safely earthed.

## 6 Assembly and installation - VN2020 Upgrade Kit

### 6.1 Assembling the VISATRON® VN2020 oil mist detector

As shown in the figure below, the VISATRON® VN2020 oil mist detector with protective cover (①) is attached by four through-holes ( $\varnothing$  9 mm) in the engine wall or on a bracket provided by the customer, using x4 M8 nuts (②).

#### NOTE

##### Operating the oil mist detector correctly

- ▶ The permissible installation tolerance, as per the following figure, is +/- 3° deviation from the horizontal alignment.
- ▶ The recommended side for mounting on the engine is opposite to the side of the explosion protection valves.
- ▶ Familiarise yourself with the general safety instructions before starting installation. ⇒ Section 2.2 General safety instructions
- ▶ Follow the instructions in Sections 6.1 and 6.2 of the current version of the VISATRON® VN2020 operating manual. ⇒ Section 1.3 Applicable documents and regulations

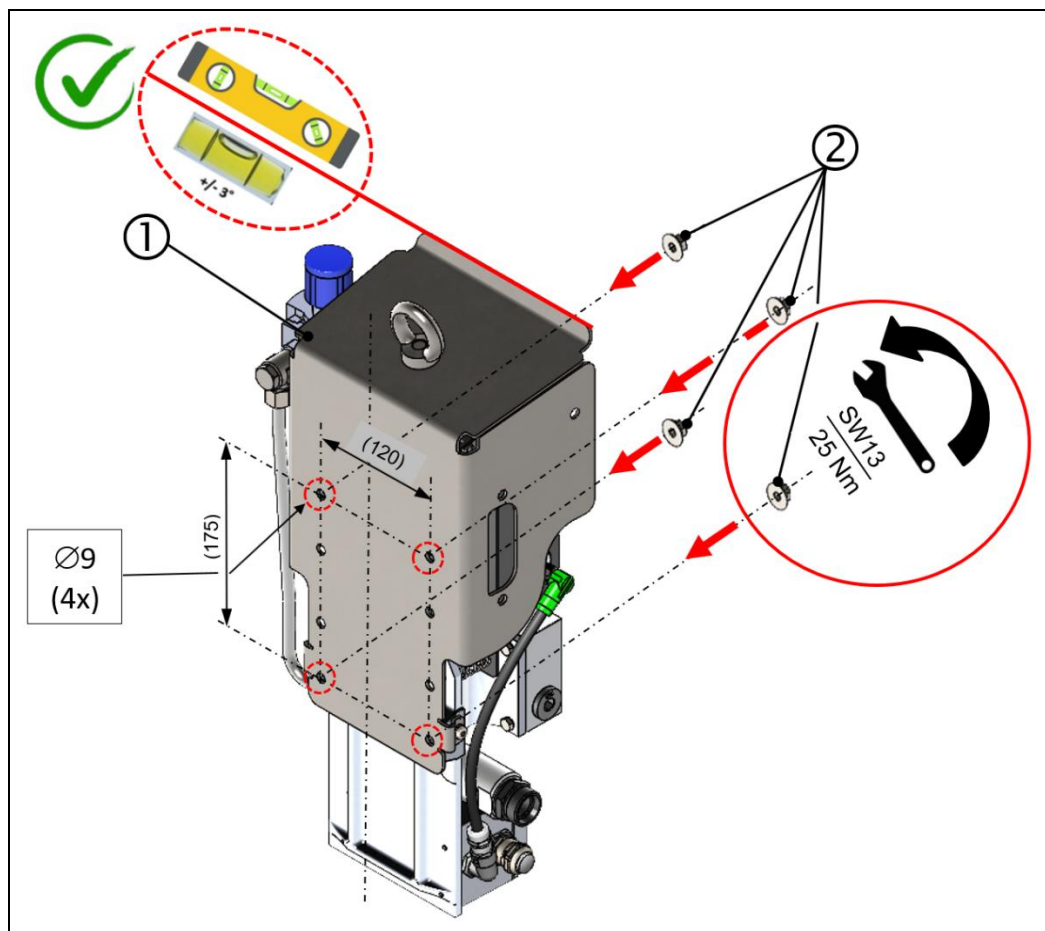

Fig.: 7 : Assembly steps for the VN2020 Upgrade Kit (rear view)

1: VISATRON® VN2020 Upgrade Kit

2: 4 pcs. ROMOB M8 St nuts (included in delivery)

## 6.2 Assembling the intake and connection lines

In accordance with Section 5 of these instructions (⇒ Section 5 Taking out of service, disassembly (used device)),

the existing and installed intake line (②) continues to be used to operate the VISATRON® VN2020 (①).

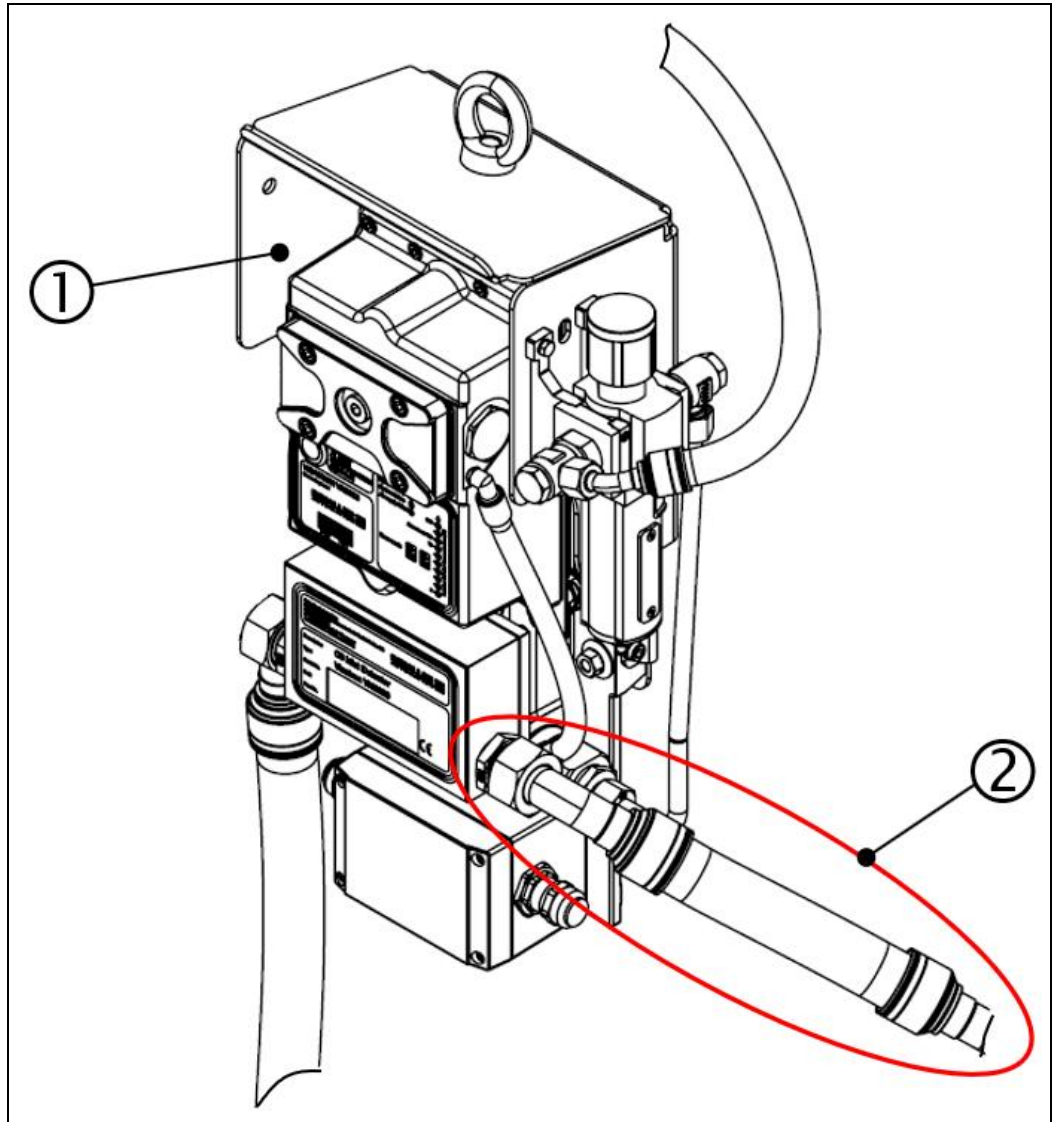

Fig.: 8 : Intake line, VN2020 Upgrade Kit

1: VISATRON® VN2020 Upgrade Kit

2: Intake line (from existing installation)

- Any adjustments to the intake line (②) and/or other connection lines to the VISATRON® VN2020 must be carried out on site by qualified personnel.

⇒ Section 1.5 Qualifications of personnel

### 6.3 Installing the return line (exhaust air hose)

If a VISATRON® VN87/VN87plus was previously used with an open circuit, i.e. where the sampled crankcase atmosphere was discharged into the environment after measurement, piping work and holes are now required on the inspection flaps (or service flaps) to create a closed circuit.

#### IMPORTANT INFORMATION



#### Assembling the connection for the return line correctly

- ▶ The connection for the return of the sampled crankcase atmosphere (return line) is installed **on the inspection cover of the engine only**.
- ➔ **For safety reasons, the engine housing wall must not be used to create through-holes.**

The VISATRON® VN2020 Upgrade Kit contains three flexible hose lines of different lengths as shown in the following figure, which are used as return line (exhaust air line) in accordance with the installation kit drawing. ➔ *Section 3.1 Items included in the Upgrade KIT*

Depending on the installation space, **one** of the three hose lines is used, as experience has shown that the required length, angle, alignment and position of the lines vary within the engine types.

As a general rule, the hose lines are pre-assembled in a first step, so that they can be installed free of stress as far as possible right from the start. Only after all components have been fully installed are all screw connections finally tightened to the defined tightening torque in accordance with EN ISO 8434-1.



Fig.: 9 : Flexible hose line, VN2020 Upgrade Kit



#### CAUTION

#### Using the device safely and correctly (in accordance with the figure below)

- ▶ To use the device safely and correctly (①), the exhaust air pipe (②) **must** be connected to the crankcase (④) at all times, thereby creating a closed circuit between the intake and return of the crankcase atmosphere.



**IMPORTANT INFORMATION**



**Assembling the device safely and correctly (in accordance with the figure below)**

- ▶ The exhaust air pipe (②) for the return of the sampled crankcase atmosphere must **not** be longer than a total length of 4 metres.
- ▶ The connection (③) for the exhaust air pipe on the crankcase must not be near an intake point.
- ▶ In the return line (②), the 3/4-inch connection must not be reduced.
- ▶ The minimum distance is defined as an oval area with a height [H] of 300 mm and a width [W] of 200 mm around the exhaust air pipe (②).

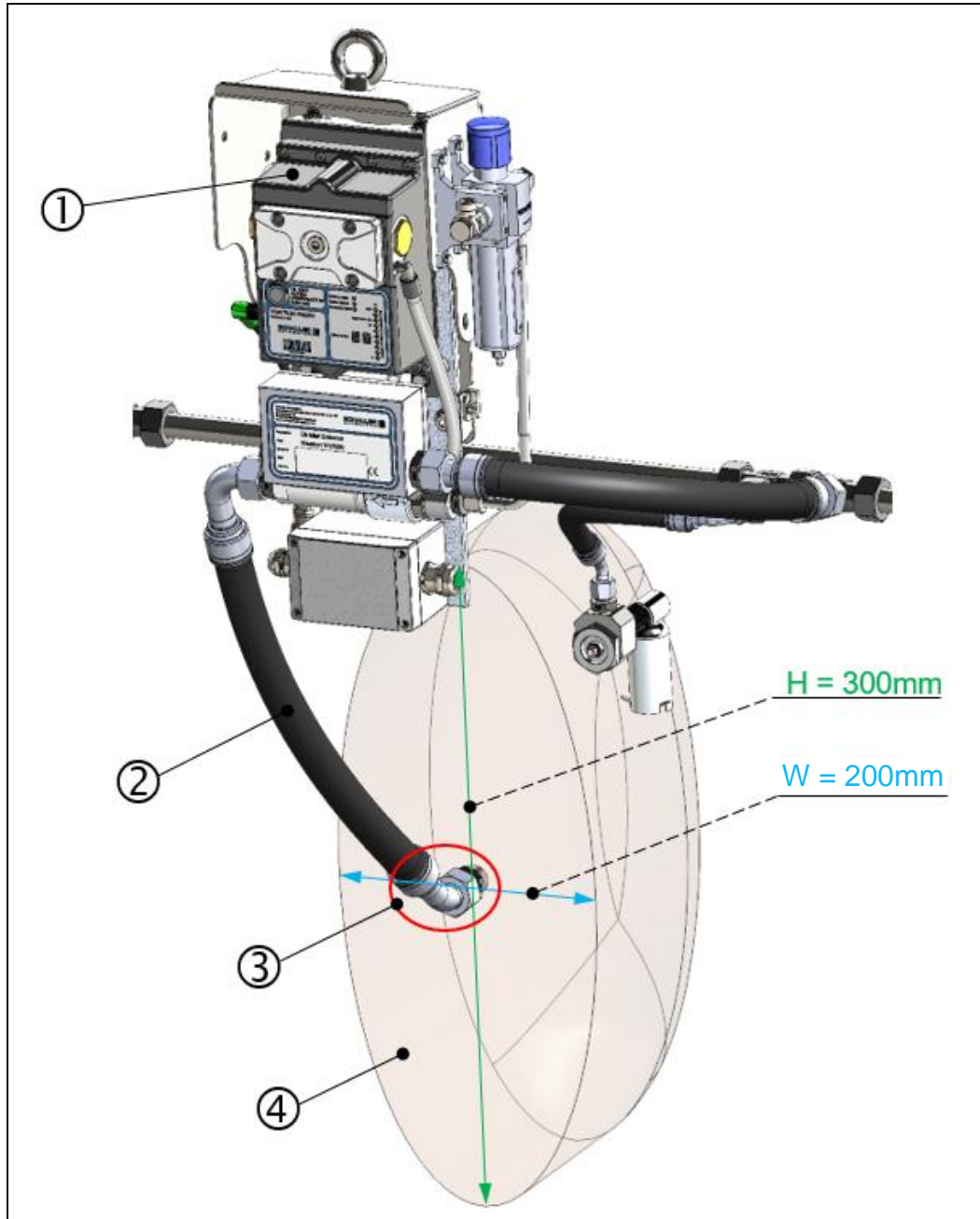

Fig.: 10 : Position of the return line, VN2020 Upgrade Kit

1: VISATRON® VN2020 Upgrade Kit  
3: Crankcase connection

2: Exhaust air pipe/line  
4: Crankcase

### 6.3.1 Installing the return line for inspection cover with wall thickness > 5 mm

**Required tools:**

- ▶ Torque spanner AF size 32 for torque up to 180 Nm (step 3).
- ▶ Torque spanner AF size 36 for torque up to 150 Nm (step 6).

The line is installed in accordance with the installation steps below:

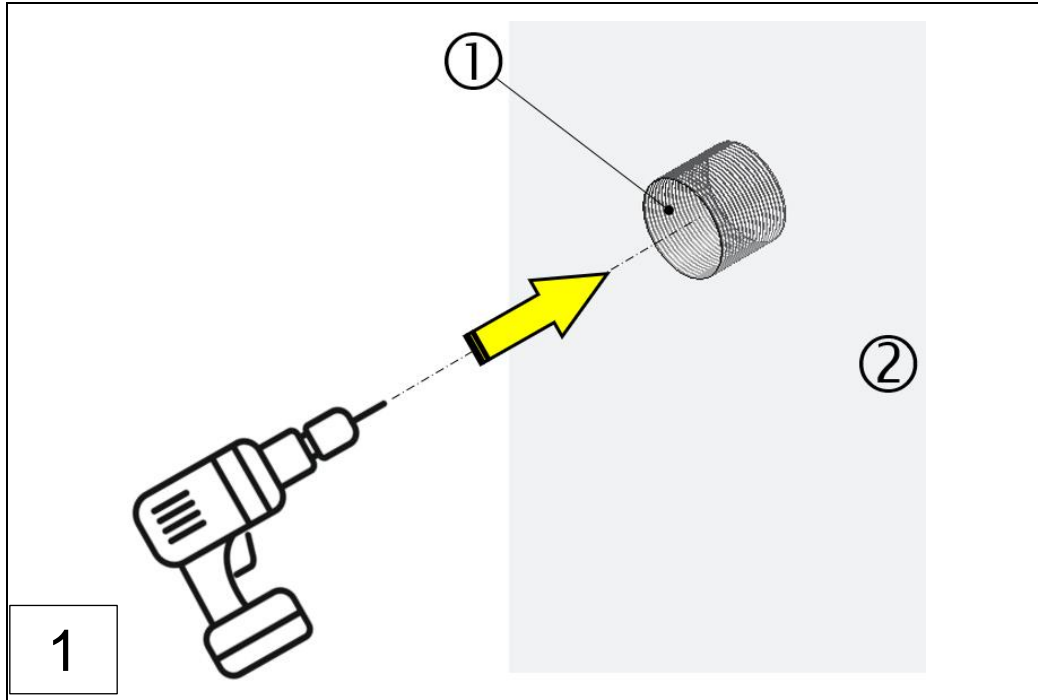

1: Core hole/connection thread G3/4"

2: Inspection cover

- ▶ Drill the core hole  $\varnothing 24.5\text{mm}$ . (①)
- ▶ Create the connection thread G3/4" (①) in the core hole.

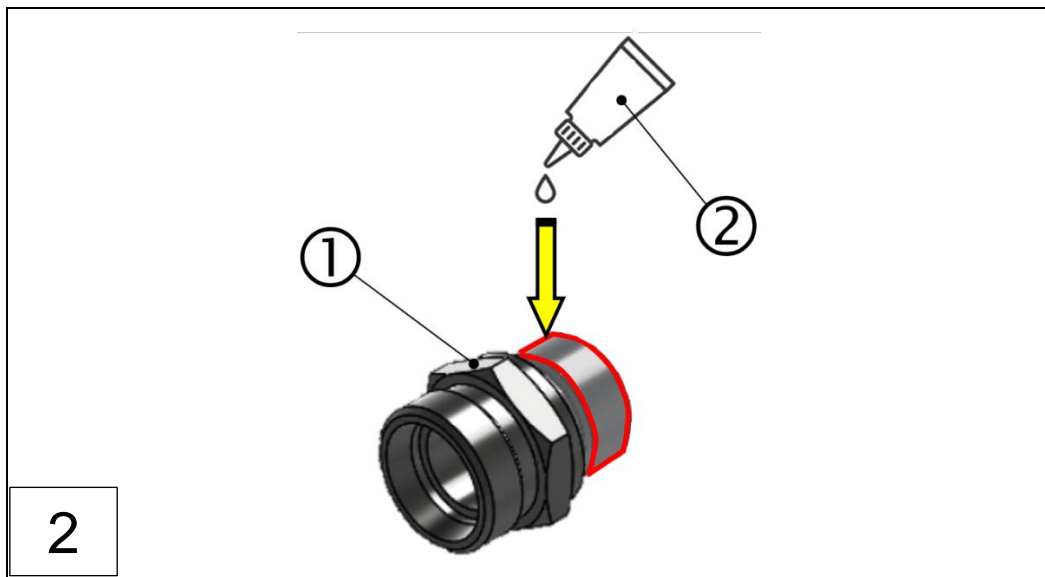

1: Straight screw-in socket L22 (G3/4")

2: Loctite 243 (adhesive for thread locking)

- ▶ Apply Loctite 243 (②) (included in the delivery) to the screw-in thread of the straight screw-in socket (①).

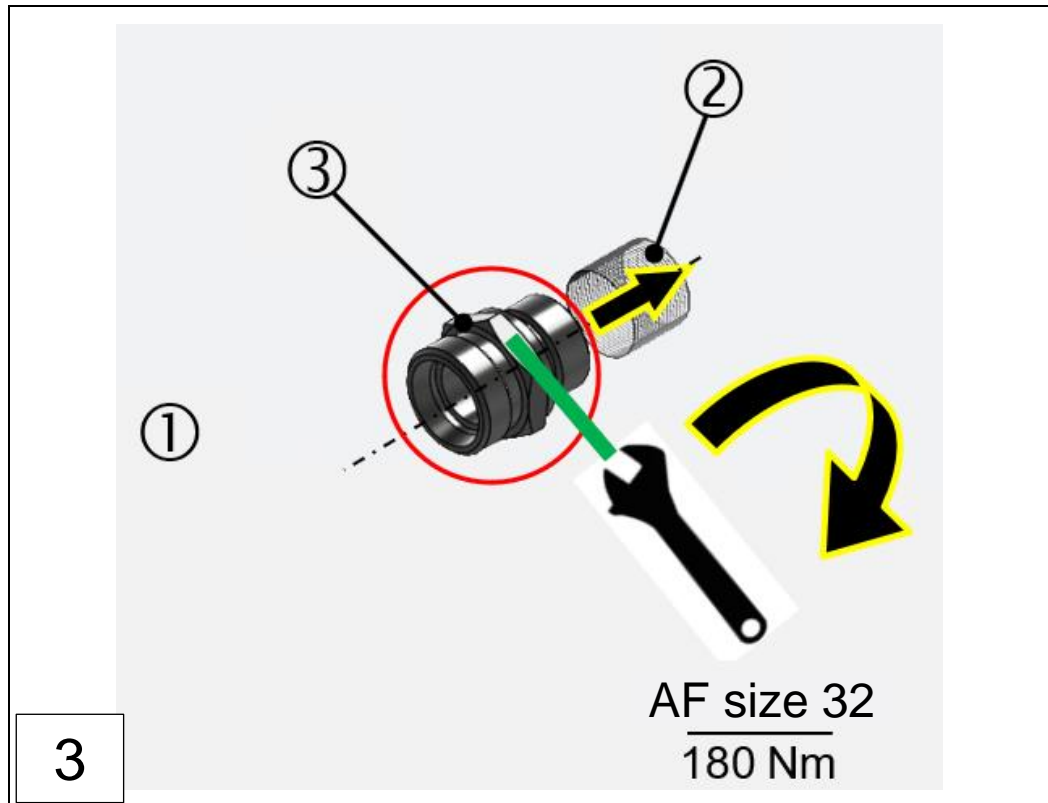

1: Inspection cover

2: Connection thread of the inspection cover

3: Straight screw-in socket L22

- ▶ Screw the screw-in socket G3/4" (③) into the connection thread G3/4" (②) hand-tight.
- ▶ Use a torque spanner, AF size 32, to tighten the screw-in socket (③) to a torque of 180 Nm.

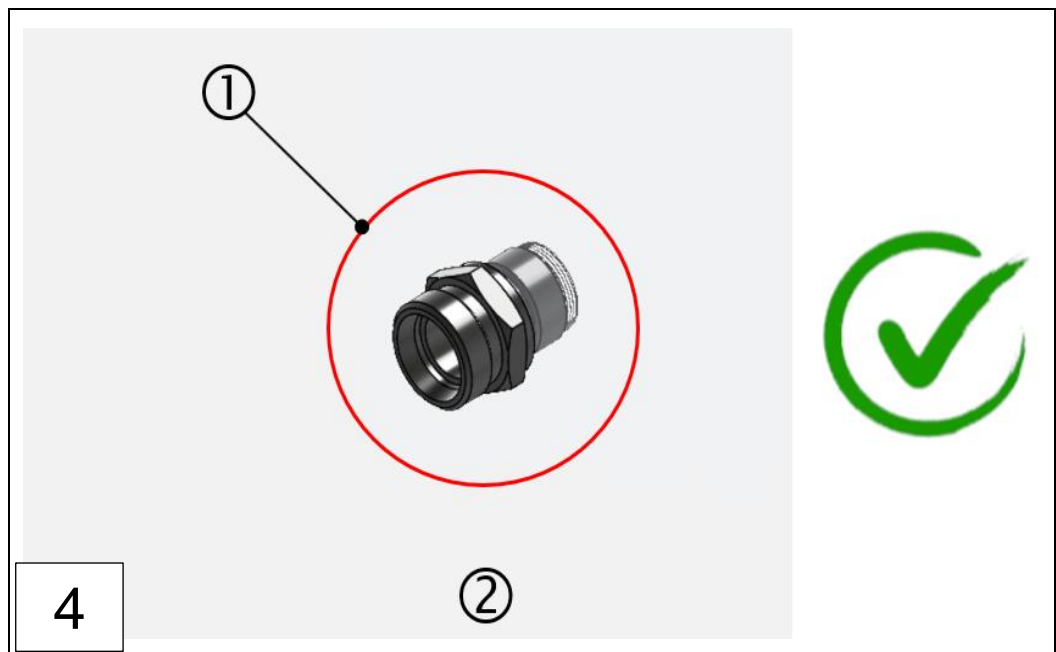

1: Straight screw-in socket L22, installed

2: Inspection cover

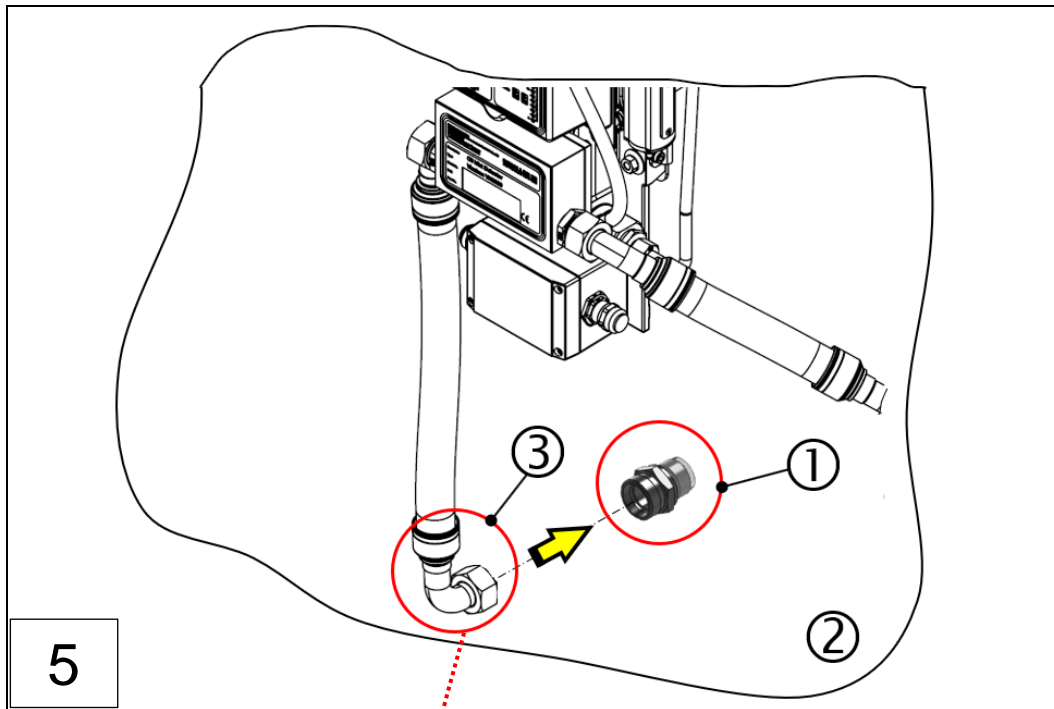

1: Straight screw-in socket L22, installed  
3: Screw fitting for exhaust air pipe/line

2: Inspection cover

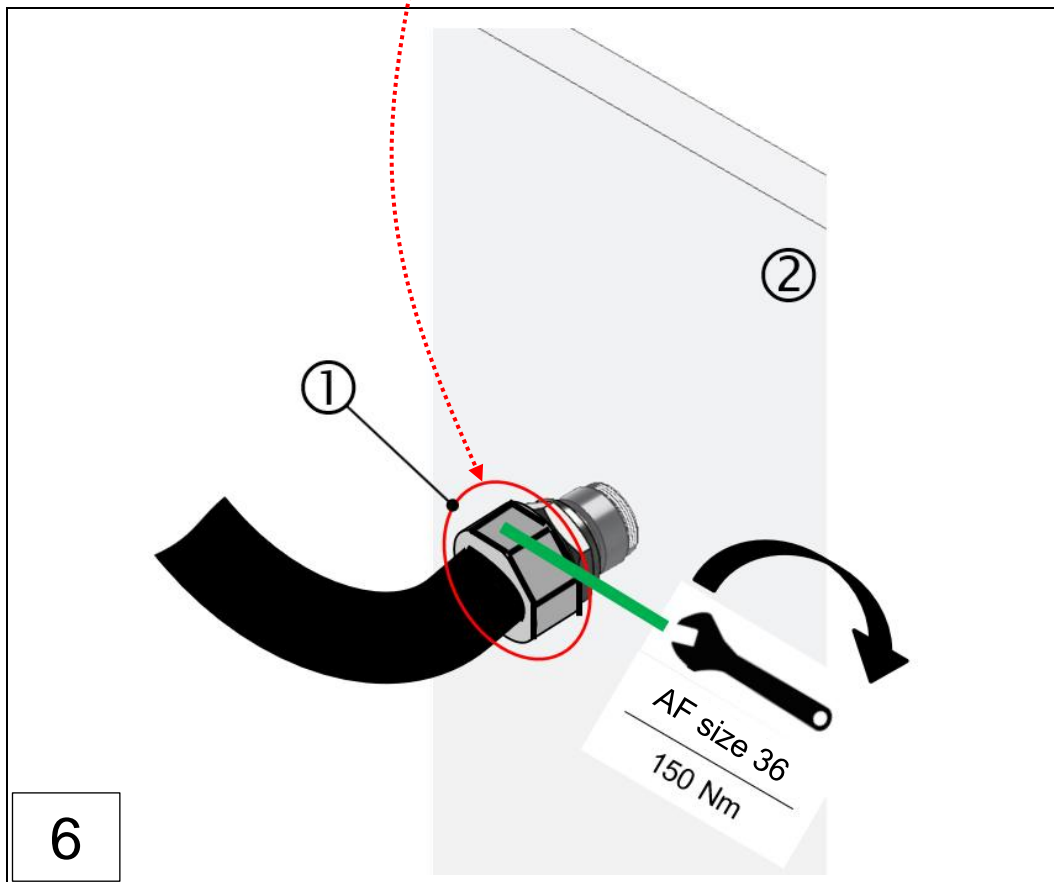

Fig.: 11 : Installing the return line, VN2020 Upgrade Kit (steps 1-6)

1: Screw fitting installed for exhaust air pipe/line

2: Inspection cover

### 6.3.2 Installing the return line for inspection cover with wall thickness $\leq 5$ mm

**Required tools:**

- ▶ Torque spanner AF size 36 for torque up to 150 Nm (steps 4 and 6).

The line is installed in accordance with the installation steps below:

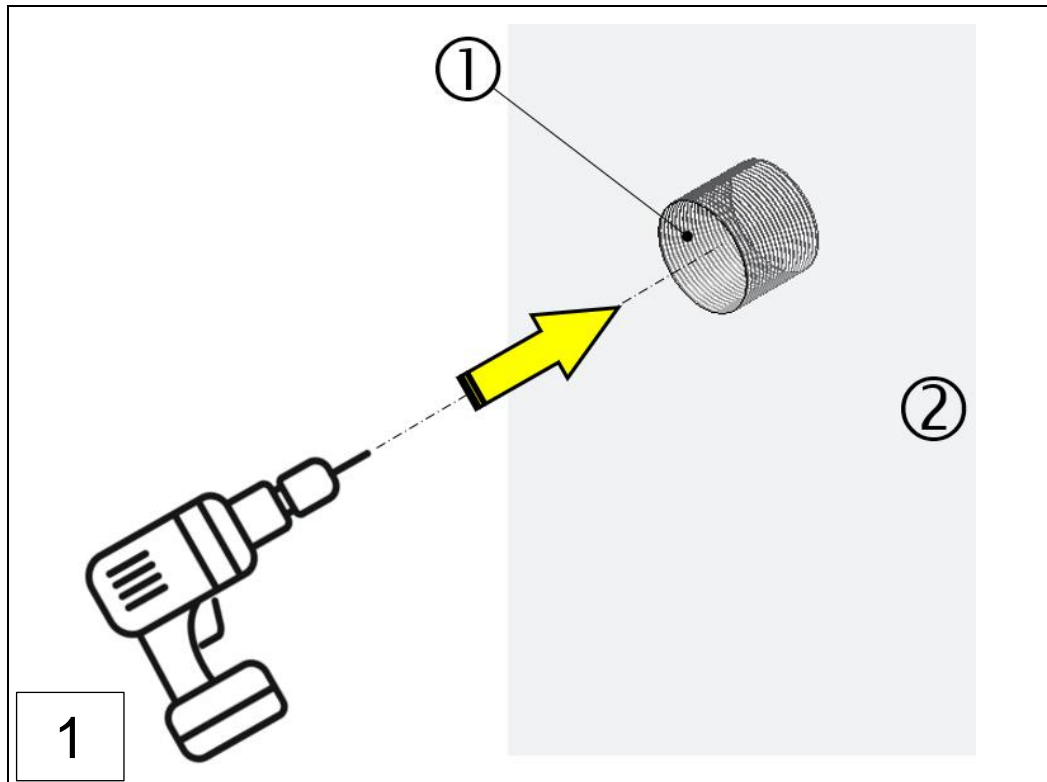

1: Core hole/connection thread

2: Inspection cover

- ▶ Drill the through-hole  $\varnothing 27^{+0.2}$  mm. (①)

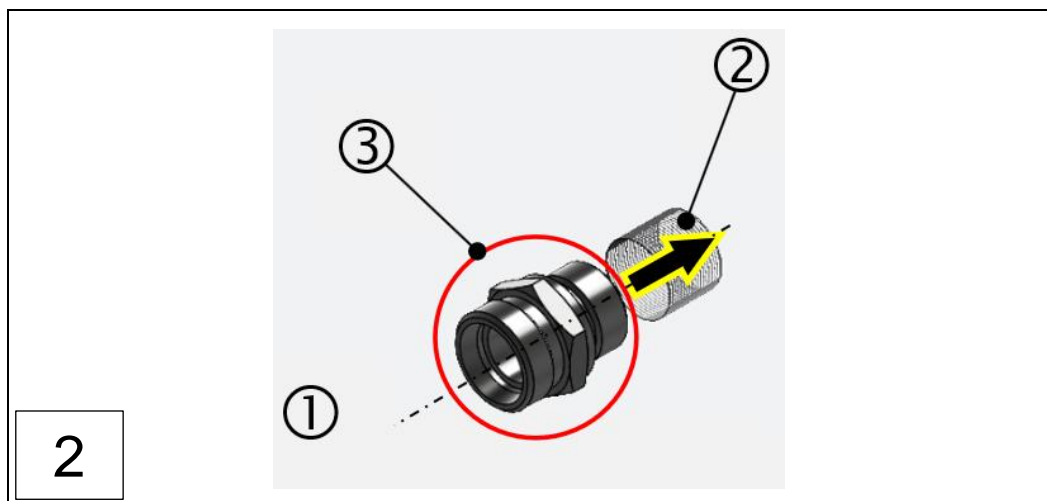

1: Inspection cover

2: Through-hole of the inspection cover

3: Straight screw-in socket L22

- ▶ Push the screw-in socket G3/4" (③) through the through-hole (②) of the inspection cover until it reaches the (mechanical) end position.

### IMPORTANT INFORMATION



#### Installing correctly

- ▶ For inspection cover wall thicknesses **up to  $\leq 5$  mm**, use Item 140 (according to Table 6) and Item 90 (according to Table 5).

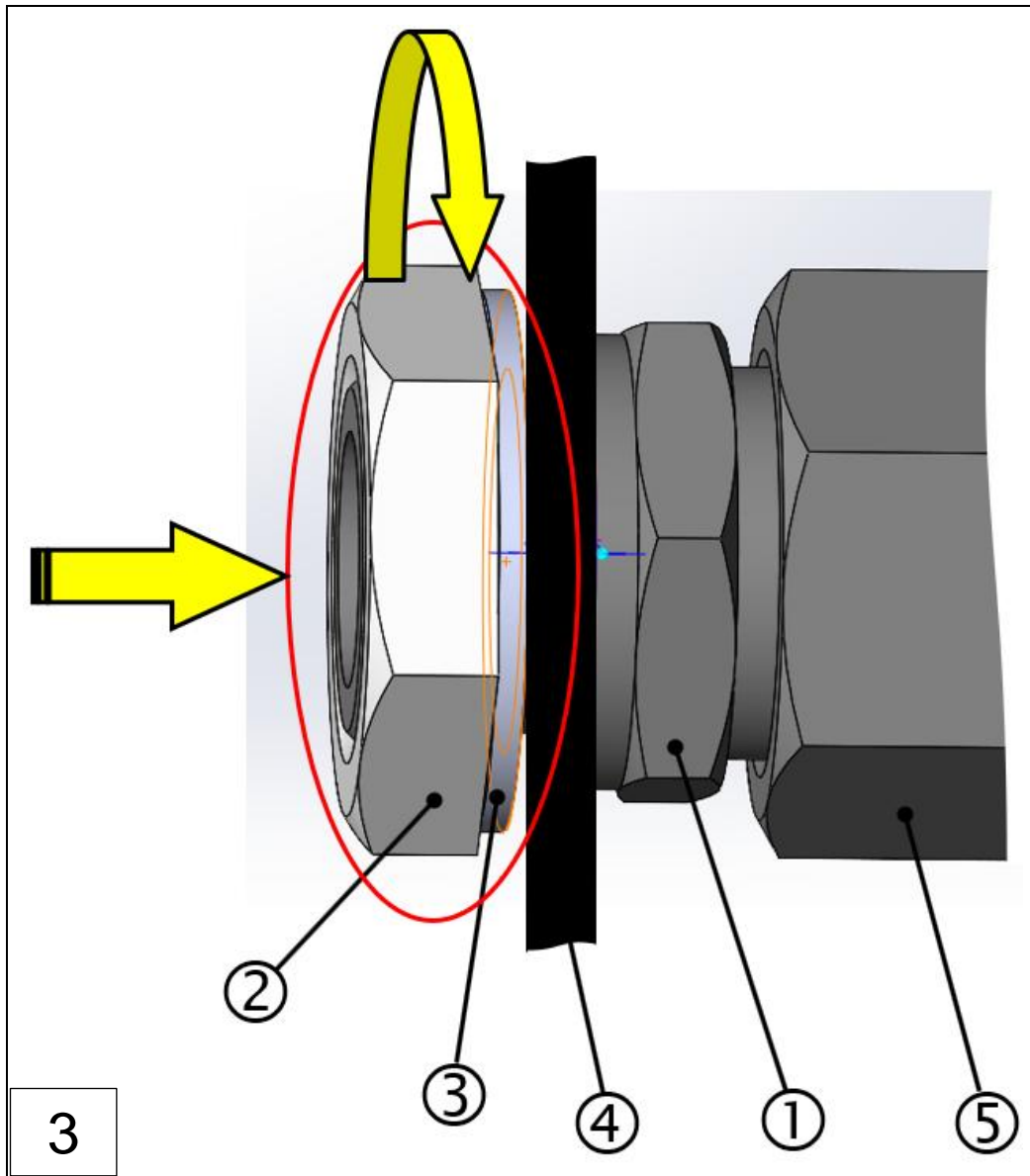

1: Straight screw-in socket L22

3: Lock washer

5: Screw fitting installed for exhaust air pipe/line

2: Hex nut DIN 431 - G3/4

4: Inspection cover

- ▶ Fit the lock washer (③) and hex nut (②) on the back of the inspection cover (④) onto the screw-in socket (①), and initially tighten hand-tight until the (mechanical) end position is reached.

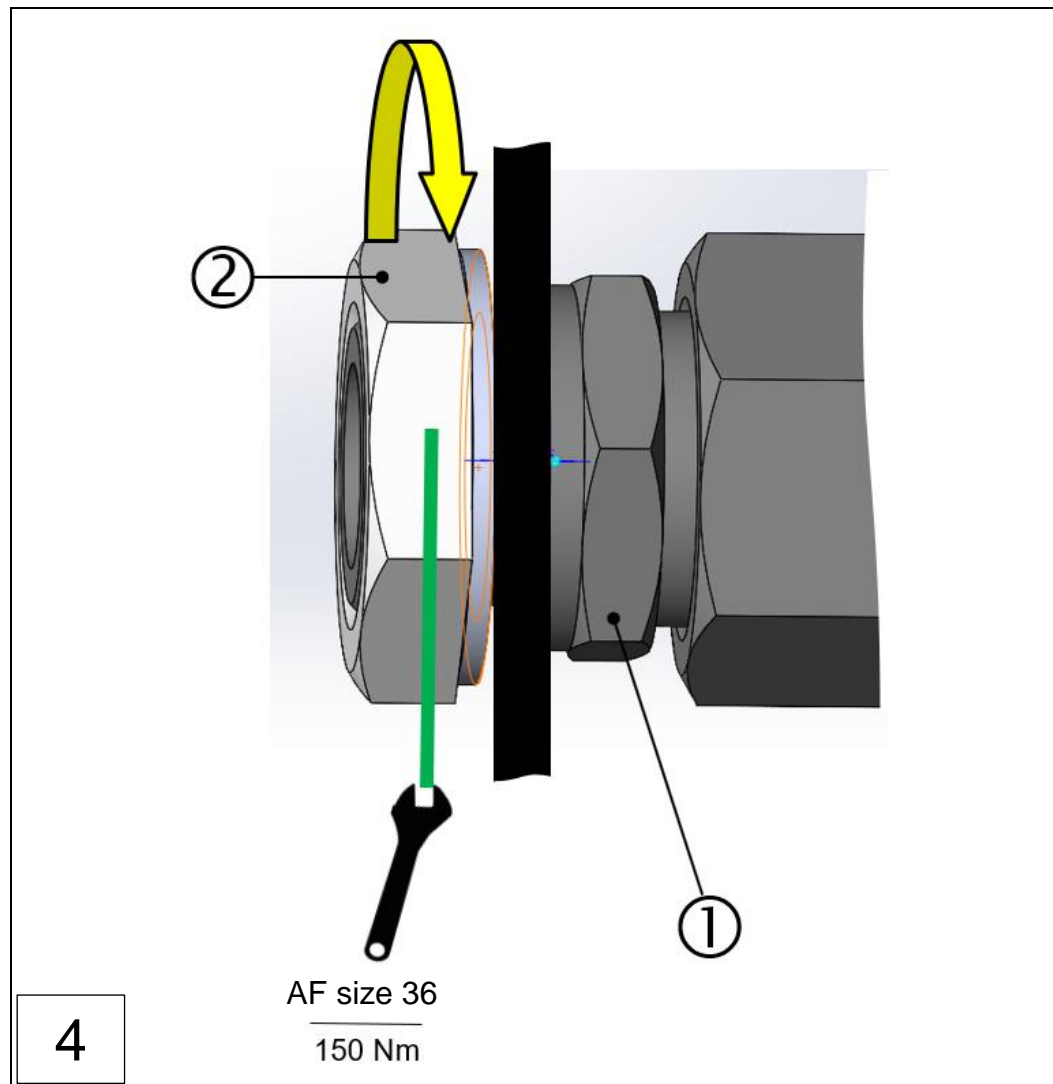

1: Straight screw-in socket L22

2: Hex nut DIN 431 - G3/4

- ▶ Use a torque spanner, AF size 36, to tighten the hex nut (②) to a torque of 150 Nm.
- ▶ Finally, carry out installation steps 5 and 6 as described in Section 6.3.1.  
⇒ Section 6.3.1 Installing the return line for inspection cover with wall thickness > 5 mm

## 6.4 Electrical installation of the terminal box

The electrical installation of the terminal box is carried out in accordance with Section 6.4.2 of the current version of the VISATRON® VN2020 operating manual.

⇒ Section 1.3 Applicable documents and regulations

### NOTE

#### Installing the device correctly

- ▶ On the previously used oil mist detector, start by checking that the wire break resistors (①) are present and their ratings. The resistors may be on the back of the measuring head under the plastic cover, as shown in the figure below.

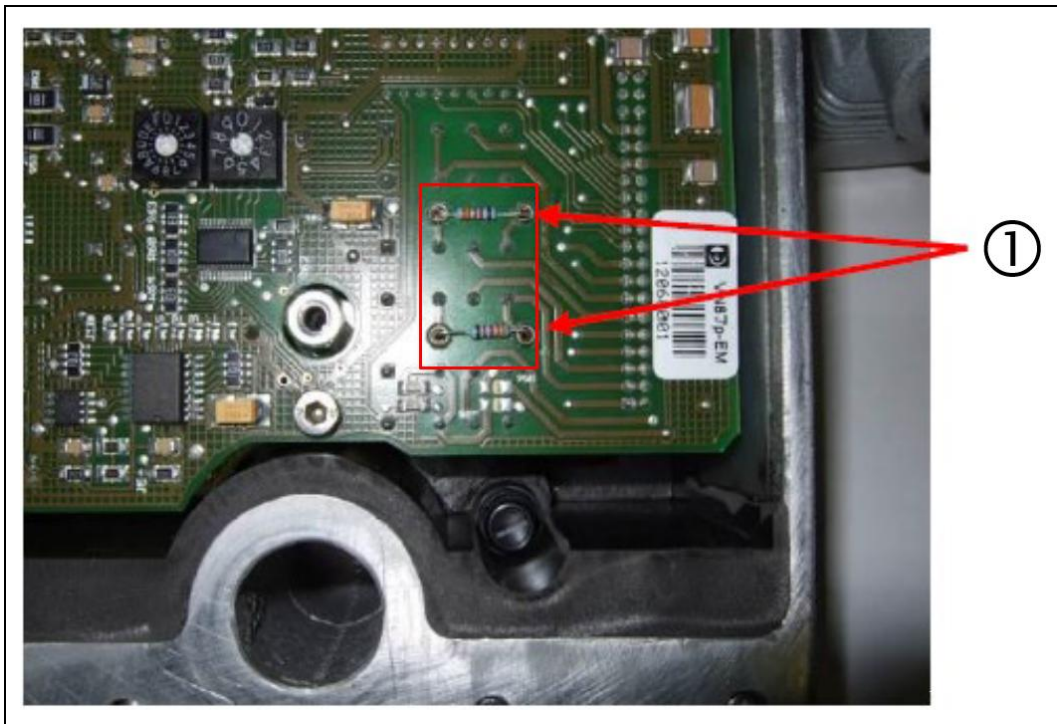

Fig.: 12 : Wire break resistors, "Measuring head of used device", VISATRON® VN87/VN87plus

1: Wire break resistors

Compared to the VN87/VN87plus, the VISATRON® VN2020 has a modified terminal layout, which is now integrated in a separate terminal box.

The following table compares the pin assignment of the old and new oil mist detector systems. For the electrical installation of the VISATRON® VN2020 Upgrade Kit, the connections in the terminal box must be assigned as follows:

Descriptions		115/87 PINS 116/87 PINS	VN2020 PINS
POWER SUPPLY	24V DC+	1	1
	24V DC -	2	2
OMD FAILURE	NC	3	8
	NO	4	10
	COM	5	9
OMD ALARM 1	NC	6	11
	NO	7	13
	COM	8	12
PRE-ALARM	NC	9	17
	NO		19
	COM	10	18
OMD ALARM 2	NC	14	14
	NO	15	16
	COM	16	15
RS485	RS485 B	11	6
		12	7
	RS485 A	13	5

Fig.: 13 : Pin assignment comparison table: VN87/VN87plus/VN2020 Upgrade Kit

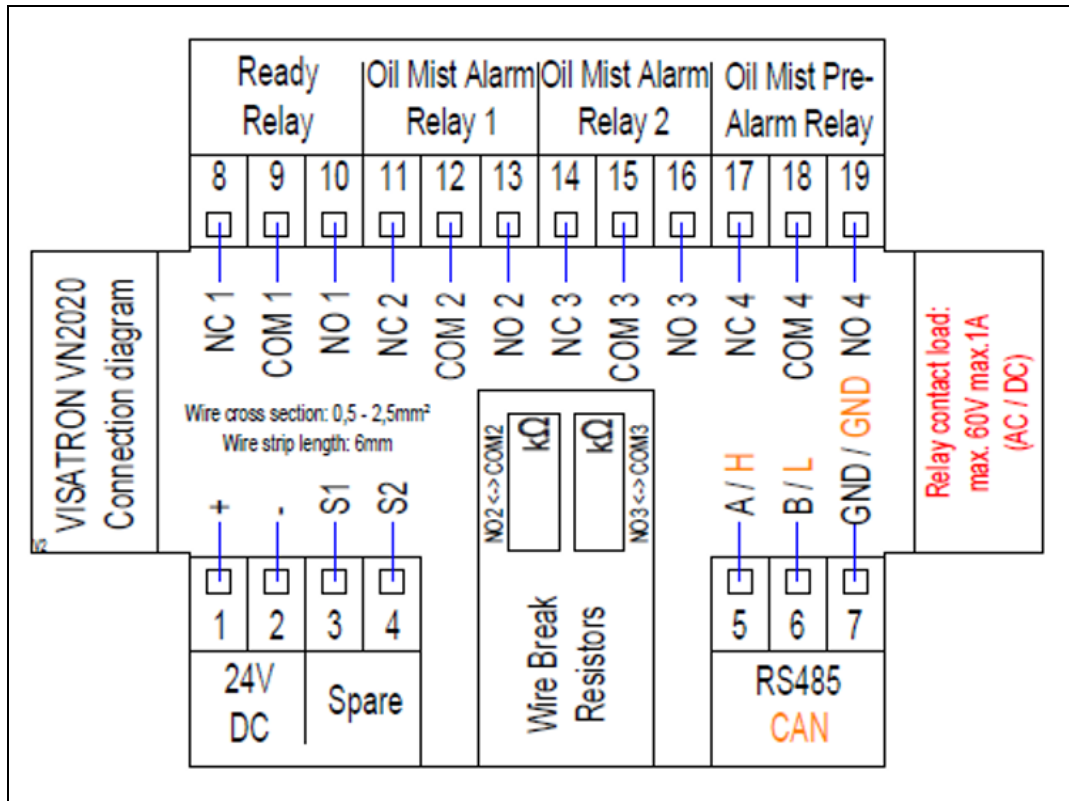

Fig.: 14 : Terminal box pin assignment – VN2020 Upgrade Kit

### 6.4.1.1 Configuration of the wire break resistors on the VN2020 terminal box

The wire break resistors are configured as shown in the figure below. As delivered, the wire break resistors are configured to 33 kΩ. However, the wire break resistors can be adapted to customer-specific requirements or swapped out. A set of suitable resistors is included in the delivery. → Section 3.1 Items included in the Upgrade KIT (-> Table 8: Set of resistors)

**NOTE**



**Swapping out wire break resistors**

- ▶ The wire break resistors are only plugged in and permanently secured by the springs inside. No soldering is necessary for the resistors!

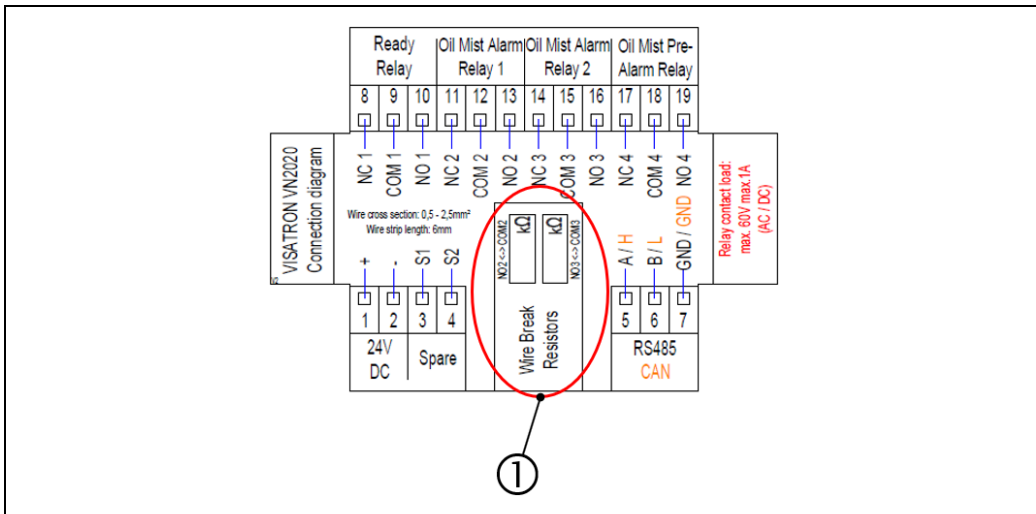
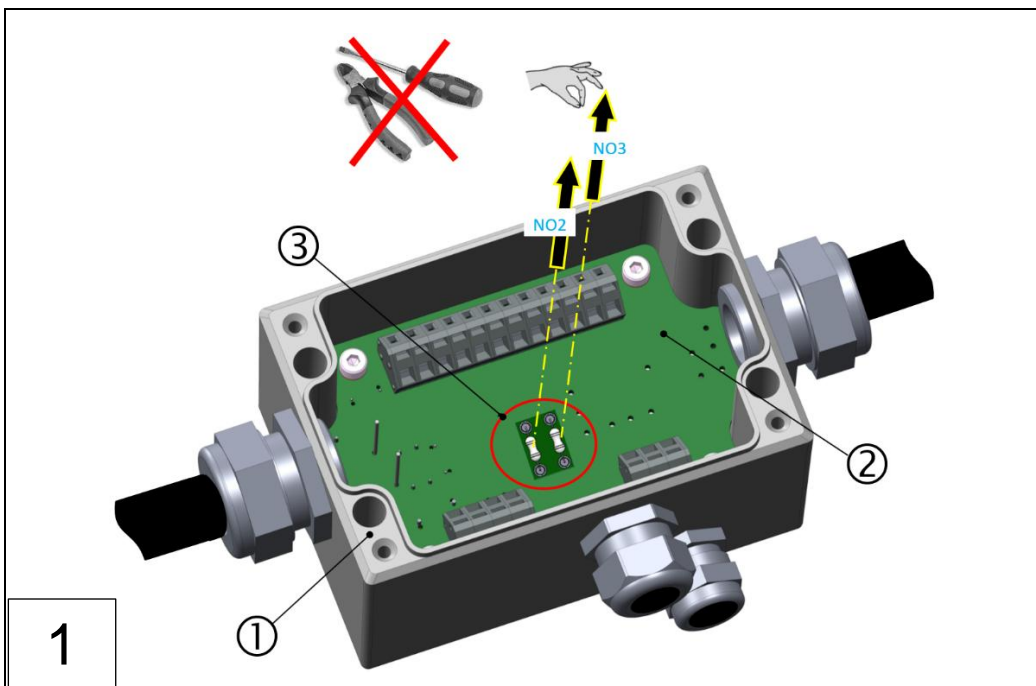

Fig.: 15 : PCB of the VN2020 terminal box: Configuration of the wire break resistors

1: Location of the wire break resistors



1: VN2020 terminal box  
3: Wire break resistors

2: Terminal box connection board

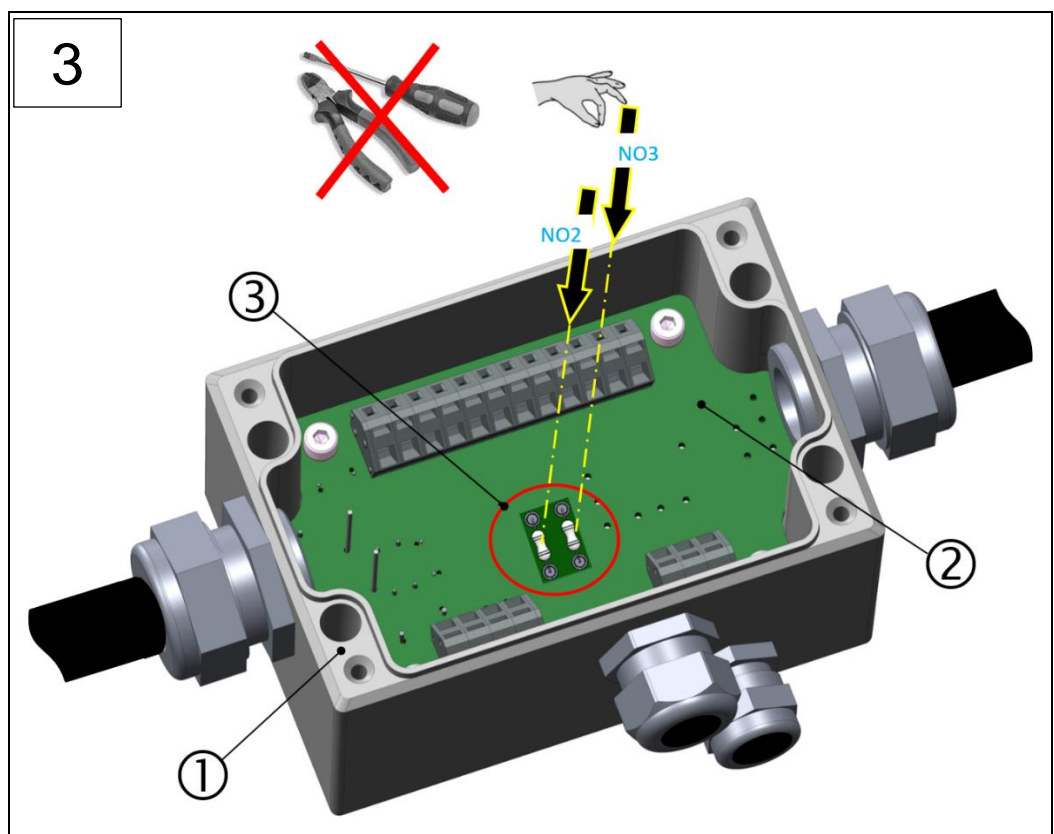
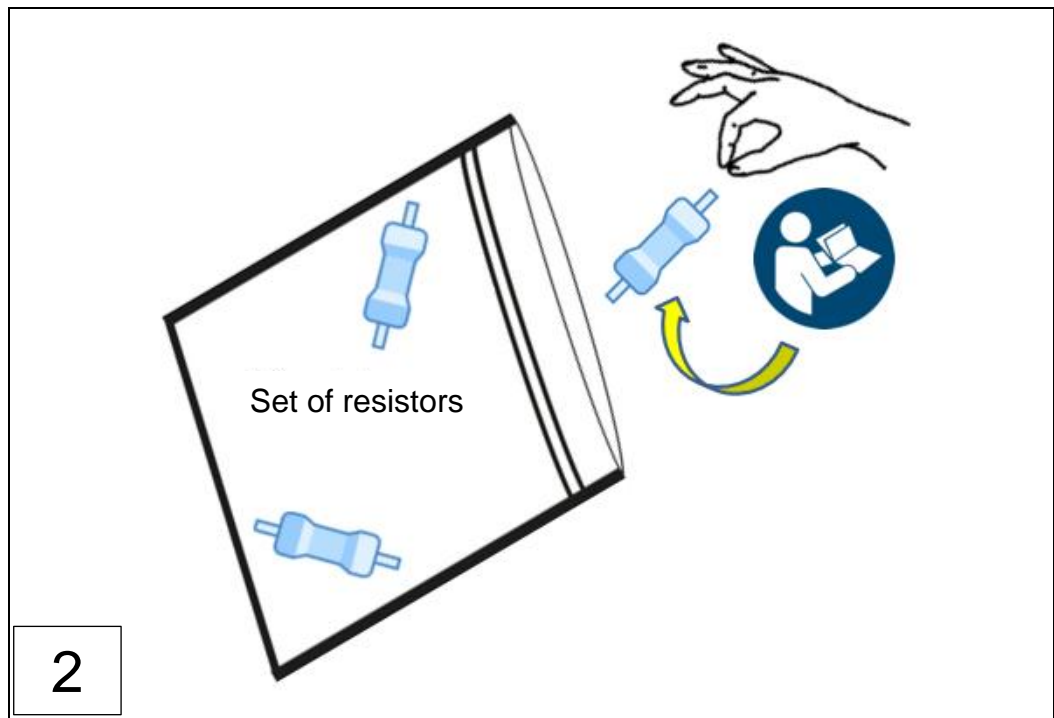

Fig.: 16 : VN2020 terminal box: Insert wire break resistors (installation steps 1-3)

1: VN2020 terminal box

2: Terminal box connection board

3: Wire break resistors

## 6.5 Electrical connection of the Remote Indicator II (optional)

The electrical installation of the Remote Indicator II is carried out in accordance with Section 6.4.3 of the current version of the **VISATRON® VN2020** operating manual.

⇒ Section 1.3 *Applicable documents and regulations*

## 6.6 Closing the terminal box after completing the electrical installation

The terminal box is closed in accordance with Section 6.4.4 of the current version of the **VISATRON® VN2020** operating manual.

⇒ Section 1.3 *Applicable documents and regulations*

## 6.7 Connecting housing earth to the protective cover of the VN2020

The housing earth is connected electrically in accordance with Section 6.4.5 of the current version of the **VISATRON® VN2020** operating manual.

⇒ Section 1.3 *Applicable documents and regulations*

## 7 Putting into service, operating and using

The VISATRON® VN2020 oil mist detector is put into service, operated and used, as described from Section 6.5 ff. up to and including Section 8 of the current **VISATRON® VN2020** operating manual.

⇒ Section 1.3 Applicable documents and regulations

For further questions, please contact service at Schaller Automation.

⇒ Section 10 Contact

### NOTE

#### Setting the oil mist sensitivity on the device correctly

- ▶ According to IACS UR M67, oil mist detectors must trigger an alarm at the latest at a concentration of 2.5 mg/l. Even the lowest sensitivity of all VN2020 oil mist detectors guarantees that an alarm is triggered at concentrations of less than 2.5 mg/litre. This fully complies with the requirements of IACS UR M67.
- ▶ The customer is responsible for selecting the sensitivity of the oil mist detector.
- ▶ The detector is set to sensitivity level 2 at the factory.



## 8 Maintenance, repair and diagnostics

The VISATRON<sup>®</sup> VN2020 oil mist detector is maintained and repaired and fault diagnostics and troubleshooting of the device are carried out as described from Section 9 ff. up to and including Section 10 of the current version of the **VISATRON<sup>®</sup> VN2020** operating manual.

⇒ *Section 1.3 Applicable documents and regulations*

For further questions, please contact service at Schaller Automation.

⇒ *Section 10 Contact*

## 9 Spare parts and accessories, VN2020 (extract)

The complete list of all spare parts and accessories is available in the current VISATRON® VN2020 operating manual from Section 13 onwards. In this regard, please also note the maintenance intervals specified in Section 9 of the manual.

⇒ Section 1.3 Applicable documents and regulations

The "VN2020 service box" maintenance set is available as a spare part and can be ordered separately.

Part Number	Description	Unit	Quantity	Price info
151906	<p><b>Service box for VN2020/VN2020 EX</b></p> <p>The service box contains all the tools and parts required to maintain and check the oil mist detector. The service box includes a contents list and manual on CD or DVD.</p> 	Pcs	1	On request!

Table 10: Service box for the VISATRON® VN2020/VN2020 EX

## 10 Contact

You can use the following contact details to contact customer service at Schaller Automation:

### **SCHALLER Automation (Headquarters)**

Industrielle Automationstechnik GmbH & Co. KG  
Industriering 14  
66440 Blieskastel, Germany  
Phone: +49 6842 508 0  
Fax: +49 6842 508 260  
Email: [info@schaller.de](mailto:info@schaller.de)  
Website: [www.schaller-automation.com](http://www.schaller-automation.com)

### **Schaller Automation LP**

811 Shotgun Road  
Sunrise, FL 33326  
United States of America  
Phone: +1 954 794 1950  
Mobile: +1 561 289 1495  
Fax: +1 954 794 1951  
Email: [info@schalleramerica.com](mailto:info@schalleramerica.com)

### **Schaller Automation Pte Ltd.**

114 Lavender Street  
#09-93 CT Hub 2  
Singapore 338729  
Phone: +65 6643 5151  
Mobile: +65 9788 7550  
Fax: +65 6643 5150  
Email: [info@schallersingapore.com](mailto:info@schallersingapore.com)  
Website: [www.schaller.sg](http://www.schaller.sg)

### **Schaller Automation – China**

Room 401, Juyang Mansion No. 1200  
Pudong Avenue,  
Shanghai 200135, P.R.China  
Phone: +86 21 5093 7566  
Mobile: +86 1390 1890 736  
Fax: +86 21 5093 7556  
Email: [info@schallerchina.cn](mailto:info@schallerchina.cn)



You can also find all our certified partners on our homepage at:

<https://schaller-automation.com/partner/>



**SCHALLER**   
AUTOMATION

**OUR PASSION. YOUR SAFETY.**

- since 1956 -

